

SCHEDULE 6.4 – SERVICE DESCRIPTION
FIBER FRONTHAUL SERVICE (FFS)

1. THE SERVICE

Service Description

- 1.1 The Fibre Fronthaul Service (FFS) is a point-to-point provision of one Fiber Cable between one Baseband Unit (**BBU**) and one Remote Radio Head (**RRH**) of the Network of an Access Seeker. Any additional FFS required between one BBU and an additional RRH shall be treated as a separate Service Order, and shall be charged accordingly.
- 1.2 The Service will provide point-to-point dedicated connectivity, between the Equipment of the BBU and of the RRH, as required.
- 1.3 The Service is available to Access Seekers holding an Individual Mobile Telecommunications License.
- 1.4 The Network demarcation of the FFS Service is the point at each end of the Fiber Cable. The Access Seeker will have access to the FFS Service at the telecom room of the Access Seeker's building or the Access Provider's Point of Presence.
- 1.5 Unless otherwise agreed with the Access Seeker, the demarcation point will be an ODF placed in the Access Seeker's building where the FFS is required; or the Point of Presence. The ODF will be owned by the Access Provider. No physical access shall be granted to the Access Seeker to the Access Provider's ODF and the interface shall be terminated by the Access Provider's staff at the Access Provider's ODF at both ends and handed over to the Access Seeker's for connecting the FFS.

DEFINITIONS

Capitalised terms not defined in this Service Description are defined in Schedule 8 - (Dictionary) of the Reference Offer. Terms defined in this Service Description are specific to it.

Baseband Unit (BBU) means the unit responsible for processing the baseband signals, where "baseband signal" refers to the signal from a Remote Radio Head that is unmodulated, via an optical interface. The BBU is connected to the RRH through CPRI (Common Public Radio Interface) Fibre Cables.

Block means a geographical area within the Kingdom of Bahrain as defined by the Ministry of Works, Municipalities Affairs and Urban Planning.

FFS means the Fiber Fronthaul Service.

FFS Operations Manual means the operations manual set out at Annex 4 of this Schedule 6.4.

FFS Service Commencement Date means the date of successful implementation and notified handover of the FFS Service by the Access Provider to the Access Seeker on the Access Delivery Date, which shall take place immediately following completion of testing as set out in FFS Operations Manual.

Installation means the installation of an individual FFS Service as described in paragraph 1 of this Service Description.

Installation Charges means the Charges referred to as Make Ready and relevant installation Charges set out under the FFS section of Schedule 3 - (Pricing) of the Reference Offer. **Minimum Service Period** means a minimum period of twenty-four (24) calendar months for which the FFS Service will be provided, such period commencing from the FFS Service Commencement Date.

Remote Radio Head (RRH) means a remote radio transceiver that connects to the BBU via an optical interface.

Renewed Minimum Service Period means an applicable minimum period of one (1) month for which the FFS Service shall be provided, such period commencing from the expiry of a Service Period.

Service Period means the Minimum Service Period or Renewed Minimum Service Period.

2. TERMS

Use of Service

- 2.1 The FFS Service shall only be made available to connect the BBU to the RRH. The Access Seeker may not resell the FFS Service to another Licensed Operator.
- 2.2 Where the Access Provider reasonably suspects a breach of paragraph 2.1, the Access Provider may undertake an investigation of the FFS Service as provided to the Access Seeker.
- 2.3 The Access Provider shall notify the Access Seeker at least twenty-four (24) hours in advance of any inspection the Access Provider intends to conduct as part of the investigation.
- 2.4 The Access Seeker shall upon request and immediately provide the Access Provider with all required access to ensure that the investigation is reasonably conducted including but not limited to access to sites and locations hosting the BBU and RRH.
- 2.5 Pursuant to the investigation set out in 2.2 above and where the Access Provider has reasonable grounds to suspect that the Access Seeker is in breach, the Access Provider, it may refer the matter as a complaint for investigation by the Authority and, subject to the Authority's approval, suspend the FFS Service until the Authority has come to a conclusion pursuant to its investigation.

Supply of Service

- 2.6 The Access Seeker shall submit a Service Order to the Access Provider to request supply of the FFS Service, in the manner communicated by the Access Provider as set out in the FFS Operations Manual.
- 2.7 The Access Provider and Access Seeker shall follow the process outlined in the FFS Operations Manual.

3. CHARGES

- 3.1 The Access Seeker shall pay to the Access Provider the relevant Charges determined in accordance with Schedule 3 - (Pricing) of the Reference Offer. This shall include relevant Monthly Recurring Charges and relevant Non-recurring Charges associated with the Application, Field Study/ies and Installation processes, notwithstanding that the Access Seeker may pay directly the Approved Contractor for materials and installation works.
- 3.2 All Charges and sums due from one party to the other under this Agreement are exclusive of VAT. Any VAT shall be charged in accordance with the relevant regulation in force at the time of making the taxable supply and shall be paid by the paying party following receipt from the billing party of a valid VAT invoice.

4. SERVICE LEVELS

The Access Provider shall provide the FFS Services in accordance with the Service Levels specified in Schedule 7- (Service Levels) of the Reference Offer.

ANNEX 1

PROVISIONING VALIDATION TEST

The following criteria will be used to validate the required services:

Provisioning Validation Test	
Acceptance Criteria	Link Verification using Optical Time Domain Reflectometry
Test Result	Copy provided to the Access Seeker's upon request at time of testing

ANNEX 2

Fiber Fronthaul Service (FFS): PROCESS

An application for FFS should follow the process and policies set out in this ANNEX 2.



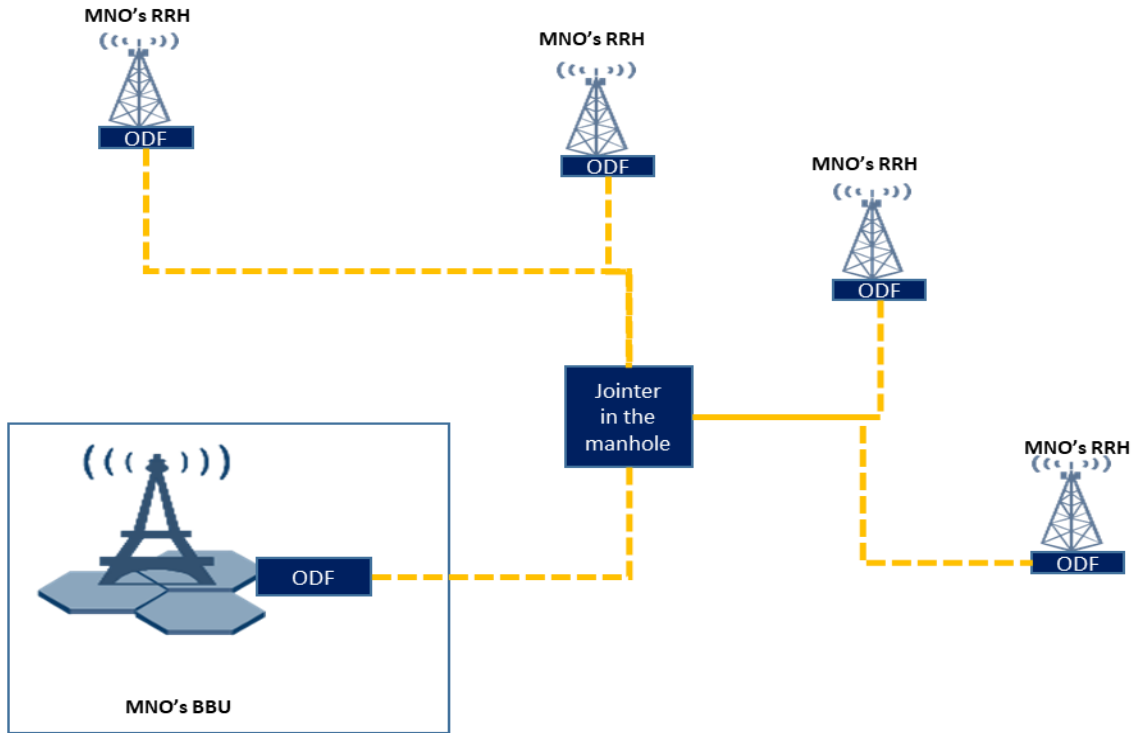

Step/Stage	Responsibility	Description	Expected Timeframe	Charges
FFS Request and Inquiry	Access Seeker	Provide information regarding FFS request	Up to Access Seeker	No
Assess Request	Access Provider	Return to Access Seeker if incomplete information	Up to five (5) Working Days unless extended as per schedule	BD 100.00 (NRC). As a processing application fee per FFS request per connection
Solution Design	Access Provider	Which includes Desk study, Field study, solution design architecture,	Thirty (30) Working days	Based on Time and Materials
Confirm Proceed	Access Seeker	If application is to proceed then Access Seeker must confirm or withdraw	Fifteen (15) Working days	No fees. Proposal remains valid for Fifteen (15) Working days.
Implementation	Access Provider	Implementation of the requested FFS as provided in Solution Design stage after the confirmation by Access Seeker	Based on the proposed plan	As per the contract Proposed solution Design

ANNEX 3

Fiber Fronthaul Service (FFS): connectivity layout



LEGENDS:

 ODF	 MNO's RRH	 MNO's Mobile radio site/BBU	 Passive Infrastructure between BBU to RRH	 Jointer in the manhole
Passive Infrastructure pairs between BBU and RRH sites				Distribution of Passive Infrastructure pairs between BBU and RRH sites