



**THIS REFERENCE OFFER IS MADE BY
BAHRAIN NETWORK (BNET) B.S.C (CLOSED)**

**02 April 2023
as amended with effect from 1 March 2025**

THIS REFERENCE OFFER IS MADE BY:

BAHRAIN NETWORK (BNET) B.S.C (CLOSED) (the “Access Provider”) **ON: 2 April 2023 – as further amended for the Network Right of Use (NRU) Service with effect from 1 August 2024, and as amended for the Managed (MDS-M) and Unmanaged (MDS-U) Service effective from 9 October 2024 and as amended for the inclusion of new WBS speeds from 1 March 2025.**

BACKGROUND:

- A. Under Article 40(bis)(a) of the Telecommunications Law it is stated that the Authority “[...] shall make the Fixed Telecommunications Infrastructure Network License available. Unless the Authority determines otherwise, non-holders of this license shall not deploy or maintain a fixed telecommunications infrastructure in the Kingdom, including in relation to the deployment and ownership of ducts and fibre optics.”
- B. On 30 May 2019 the Authority, pursuant to the requirements of Article 40(bis)(a) of the Law, granted the Access Provider the Fixed Telecommunications Infrastructure Network License (the “**BNET License**”).
- C. The Resolution No. (17) of the year 2020 Promulgating the Fifth National Telecommunications Plan (NTP5), issued on 25 October 2020, confirmed - consistent with the ‘single network objective’ - the role of BNET as owner and operator of the fibre- based national broadband network in the Kingdom, providing equivalent access to all other licensees on equivalent terms and conditions. BNET’s national broadband network is also considered an essential input for mobile operators, with fibre backhaul and fronthaul being an increasingly important input to mobile data services, including 5G services.
- D. The BNET License requires BNET to provide all Licensed Operators with wholesale services and products on the terms set out in this Reference Offer and/or as required by the Telecommunications Law and/or the BNET License.
- E. BNET is fully committed to supply such products or services on an equivalence of input basis and consistent with the principles of transparency and non-discrimination, without any differences between BNET’s Affiliates, which are Licensed Operators, and any other Licensed Operators.
- F. Pursuant to section 4.9 of the BNET License, BNET is required “*At the request of the Regulator and/or every twenty-four (24) months (whichever is the shorter)... [to] submit a draft Reference Offer for the Regulator’s approval within a period of time determined by the Regulator*”.
- G. Pursuant to section 4.10 of the BNET License, following approval by the Authority of the draft Reference Offer, BNET shall “*within two weeks of the approval... publish the Reference Offer in the version approved on its website... Any proposed change (including updates) to the terms of the Reference Offer shall require the prior written approval of the Regulator*”.
- H. Pursuant to section 4.1.2 of the BNET License BNET is obligated to abide by the terms of this Reference Offer.

- I. Pursuant to section 27.1 of the BNET License, BNET is obligated, from the Effective Date of the BNET License, to provide the Licensed Services in accordance with the Reference Offer.
- J. All terms used but not otherwise defined in Schedule 8 (Dictionary) or any other part of this Reference Offer, shall have the meanings ascribed to them in the Telecommunications Law.
- K. This version of the Reference Offer is further amended from 1 August 2024 following the Authority's Approval of the new NRU Service description and the corresponding price terms.

1 THE STRUCTURE OF THIS REFERENCE OFFER AND ORDER OF PRECEDENCE

- 1.1 This Reference Offer sets out the terms and conditions on which the Access Provider will, subject to (i) conclusion of a written contract between the Access Seeker and the Access Provider and (ii) fulfilment by the Access Seeker of its obligations thereunder, provide the Services covered by this Reference Offer as described in detail in the Schedules 6 (Service Descriptions) to the Access Seeker.
- 1.2 This Reference Offer has been submitted to the Authority for their review and approval and becomes effective and legally binding on both parties on the date of an approval or an order of the Authority or on any date as determined by the Authority, (as appropriate).
- 1.3 This Reference Offer comprises:
 - (a) The Main Body of this Reference Offer including its Annex 1 - New Service Order and New Service Order Process, and Annex 2 - New Service Order form;
 - (b) Schedule 2 – Notification and Acceptance of a Service Order
 - (c) Schedule 3 – Pricing;
 - (d) Schedule 4 – Billing;
 - (e) Schedule 5 – Forecasting;
 - (f) Schedule 6 – Service Descriptions and the corresponding Operations Manuals;
 - (g) Schedule 7 – Service Levels;
 - (h) Schedule 8 – Dictionary;
 - (i) Schedule 9 - Supply Terms; and
- 1.4 If there is any inconsistency between any parts or Schedules of the Reference Offer, then the inconsistency shall be resolved in accordance with the following descending order of precedence:
 - (a) Schedule 6 (Service Descriptions) and their appended Operations Manuals;
 - (b) Schedule 3 (Pricing);
 - (c) Schedule 1 (Main Body);
 - (d) Schedule 9 (Supply Terms); and
 - (e) the other Schedules

2 MAKING AN AGREEMENT UNDER THIS REFERENCE OFFER

- 2.1 If the Access Seeker wishes to make use of any of the Service(s) covered by the Reference Offer, the Access Seeker shall enter into a binding and enforceable agreement with the Access Provider incorporating the terms of this Reference Offer in their entirety (the "**Agreement**"). This is without prejudice to any pre-existing contract between the Access Seeker and BNET entered into and based on any earlier versions of this Reference Offer. For avoidance of doubt, adoption of any subsequent version of this Reference Offer, following its approval by the Authority, does not require the parties to conclude a new Agreement or amend any such pre-existing Agreement to reflect the new terms of such Reference Offer. It is understood that any such pre-existing Agreement will incorporate the terms of the new version of this Reference Offer once approved by the Authority which terms will prevail over any earlier versions of this Reference Offer, as applicable.
- 2.2 It is understood that the terms and conditions of this Reference Offer including all its Schedules and other parts will be incorporated as terms and conditions of such Agreement. Taking account of the established practice between the Access Provider and Licensed Operators in the Kingdom, the Access Seeker and the Access Provider shall execute in writing the Agreement by signing the Supply Terms as represented in Schedule 9 of this Reference Offer, which incorporate, by reference, all the other parts of the present Reference Offer and altogether form the Agreement. A reference to this Reference Offer shall be also understood as a reference to such Agreement incorporating such Reference Offer, and reference to the Access Provider and the Access Seeker, respectively, as a "**Party**", or jointly as "**Parties**" to this Agreement, shall be construed accordingly.
- 2.3 Subject to clause 2.1 above, the Access Provider is not required to supply any Service or process a Service Order or a New Service Order of the Access Seeker until such time both Parties have entered into such Agreement.
- 2.4 As a condition for entering into this Agreement:
- (a) Unless the Parties entered into an agreement based on an earlier version of this Reference Offer, the Access Seeker must submit a signed copy of the Access Provider's Confidentiality Agreement; and
 - (b) Where the Access Provider needs to verify the credit worthiness of the Access Seeker taking into account the history, capital, including any published annual reports where available, of the Access Seeker, the Access Seeker shall provide upon request to the Access Provider evidence of the Access Seeker's Acceptable Long-Term Credit Rating, or an appropriate Financial Security including, but not limited to, in the form of a bank guarantee, or a letter of credit, as further described in Schedule 9 (Supply Terms), accepted by the Access Provider; and
 - (c) The Access Seeker shall provide to the Access Provider evidence on the insurance policy as described in Clause 16 of Schedule 9 (Supply Terms); and

(d) The Access Seeker shall demonstrate to the Access Provider that it is a Licensed Operator in the Kingdom of Bahrain with all the appropriate approvals to offer the relevant services.

2.5 By entering into the Agreement, the Access Seeker represents and warrants to the Access Provider as at the Agreement Effective Date, that:

(a) its obligations under the Agreement will be valid and binding and are enforceable against it in accordance with its terms;

(b) it is not Insolvent or subject to any Insolvency Proceedings;

(c) the Access Seeker has and will continue to have throughout the Term Acceptable Long Term Credit Rating, or an appropriate Financial Security as further described in Schedule 9 (Supply Terms);

(d) it has, and will continue to have throughout the Term, in full force and effect all the licenses necessary to use any of the Service under the Agreement;

(e) to the best of the Access Seeker's knowledge, there are currently no pending proceedings or a risk of any such proceedings, which could lead to invalidation or withdrawal of the Access Seeker's licence(s) necessary to use any of the Service under the Agreement, and

(f) in relation to a specific Service, which can only be provided to a certain category of Licensed Operators in the Kingdom, the Access Seeker has the required type of the licence, as applicable. The Access Seeker acknowledges and agrees that its failure to present evidence of such type of a licence would prevent the Access Provider from offering or continue supplying such Service to it.

2.6 The Access Seeker agrees to hold harmless and indemnify the Access Provider for any liability, loss, damage, cost or expense (including legal fees on a full indemnity basis) incurred or suffered by the Access Provider, which arise out of or in connection with any breach of any of the representations or warranties given in the clause 2.5 above as well as pursuant to Schedule 2 (Service Order), including in connection with any claim made by any third party against the Access Provider in connection with the representations or warranties set out in 2.5 above, in relation to each and every Service Order, subject to the Access Provider using all reasonable endeavours to mitigate against the effects of any such breach of the representations or warranties.

2.7 The Agreement commences on the Agreement Effective Date and continues in full force and effect, unless terminated in accordance with its terms.

3 SUPPLY OBLIGATION

- 3.1 Subject to the Access Seeker's compliance with the terms of the Agreement regarding placing any Service Order, the Access Provider shall, provide the Service(s) to the Access Seeker, as further described in this Agreement.
- 3.2 If, in accordance with Schedule 2 (Notification and Acceptance of Service Order) of the Reference Offer, a Service Order for a specific Service has been, after the Agreement Effective Date, submitted by an Access Seeker authorised to make such a Service Order and has been accepted by the Access Provider, the Access Provider shall supply the requested Service:
- (a) at the Charges specified in Schedule 3 – (Pricing) and Schedule 6 (Service descriptions) of the Reference Offer or as otherwise approved by the Authority;
 - (b) in accordance with the other terms of the Reference Offer.
- 3.3 The Access Provider shall not be obliged to provide, or enter into an agreement to provide, any services outside of the scope of Schedule 6 - (Service Descriptions) with the exception of a New Service to be offered by the Access Provider following completion a New Service Order Process as described in Annex 1 to the Main Body.
- 3.4 The timetable for the Access Provider to comply with processing orders and provisioning of Services shall be in accordance with Schedule 7 – (Service Levels) of the Reference Offer.

4 AMENDMENTS AND VARIATIONS TO THE REFERENCE OFFER

- 4.1 The Access Provider (following consultation with the industry as per the applicable consultation procedures issued by the Authority and on first obtaining any approval from the Authority as required by the BNET License), and subject to the terms of section 5.2 of the BNET License, may amend or vary the Reference Offer, including:
- (a) offering any New Service and any amendment or variation to the Reference Offer arising from the New Service, in accordance with Annex 1 to this Main Body; or
 - (b) other amendments, modifications or other alteration to the existing Service or the associated terms or conditions for its provisioning based on regular reviews of the Reference Offer; or
 - (c) withdrawing or discontinuing supply of any Service and removing the corresponding provisions from the Reference Offer as a result of such withdrawal.

ANNEX 1 - NEW SERVICES ORDER AND NEW SERVICE ORDER PROCESS

- 1.1 If an Access Seeker wishes the Access Provider to supply it with a New Service, it may submit to the Access Provider a written request to that effect (“**New Service Order**”) using the standard format provided in Annex 2 (New Service Order). Where the Access Provider identifies an opportunity to develop a New Service on its own initiative as further described in 1.23 below, it shall follow the same process as applies to an Access Seeker as is described in the present Annex 1 including using the New Service Order form.
- 1.2 This Annex describes the procedure to be followed by the Access Seeker and the Access Provider for submitting, discussing and evaluating such request, including engaging in a public consultation with the industry and the Equivalence Compliance and Technical Committee (the “ECTC”) as well as seeking TRA approval for introducing any agreed New Service into this Reference Offer.
- 1.3 As required by the principles of transparency and equivalence of input, the same process and requirements for a New Service Orders shall apply to the Access Provider’s Affiliates, which are Licensed Operators, as will apply to any other Licensed Operator.
- 1.4 The Access Provider will consider in good faith any New Service Order provided to it and in line with the following process.
- 1.5 The requirements for the form and the minimum content of a New Service Order and the method for its submission to the Access Provider are outlined in Annex 2 (New Service Order). Where this process refers to any request, submission or other similar act of the Access Seeker in writing, it may also allow for such act to use the IT systems for ordering and provisioning or other systems available or developed by the Access Provider, as applicable at the time.

Initial phase and development of a detailed Statement of Requirements

- 1.6 When making a New Service Order, the Access Seeker shall use all reasonable efforts to include in the New Service Order Form submitted to the Access Provider for consideration:
 - (a) a reasonably detailed description of the proposed New Service;
 - (b) a reasonably detailed outline of the technical, operational and functional specifications which the Access Seeker considers should apply to the New Service including description of any interfaces, where applicable;
 - (c) the Access Seeker’s opinion on the likely interest in and uptake of the New Service in general, its benefits to the end users, including, where applicable, a preliminary forecast of the Access Seeker’s’ expected use of the New Service;
 - (d) reasonable justification as to why the current service offerings in the Access Provider’s existing Reference Offer do not meet the Access Seeker’s requirements, where the Access Seeker shall demonstrate a real need for the proposed New Service including as to how the New Service will assist in promoting any technological advances in the industry or contribute to improving the customer experience;

- (e) the Access Seeker's suggestions for the commercial parameters of such New Service including any Service Levels required;
- (f) subject to the process below, an estimate on preferred timelines for testing and/or product offering.

1.7 The Access Provider shall, within five (5) Working Days of the receipt of the New Service Order:

- (a) notify the Access Seeker and confirm receipt as well as propose a reasonable timeframe for the Access Provider and the Access Seeker to meet to discuss the New Service Order. The Access Provider shall offer the first meeting (which can include using online communication or collaboration mechanisms) no later than five (5) Working Days following the Access Provider's confirmation of receipt. The New Service Order will be deemed received by the Access Provider if no confirmation has been sent to the Access Seeker within five (5) Working Days of the New Service Order being submitted to the Access Provider; and
- (b) notify the ECTC of the New Service Order received, including providing to the ECTC the following information:
 - (i) date of the New Service Order receipt by BNET; and
 - (ii) identity of the Access Seeker, which submitted the request; and
 - (iii) the Service impacted by the New Service Order referring to its designation under the applicable Schedule 6 (Service Description), unless it relates to a completely New Service in which case it will cover a brief description of such New Service, and
 - (iv) brief description of the nature of the change, amendment or other modification to any existing Service unless it relates to a completely New Service.

1.8 The parties shall, as soon as reasonably practicable and in any case not later than five (5) working days following the initial meeting between the Access Provider and the requesting Access Seeker, engage in a detailed discussion, the purpose of which is to ascertain the feasibility of the New Service and analyse all the following factors:

- (a) appropriate technical, operational and functional definition of the New Service, all its features and parameters as well as an outline of its scope;
- (b) the necessary operational process steps for its ordering and provisioning including any system requirements;
- (c) appropriate commercial terms applicable to the scoping, development, testing, implementation and supply of the New Service, including:
 - (i) the charges and pricing regime to apply to any or all those activities considering the likely time and resources required;
 - (ii) the framework, dependencies for, and scope of, any proposed testing and acceptance processes;

(iii) estimated timetable for the scoping, development, testing, implementation and supply of the New Service considering all the relevant stages of the New Service Order process following TRA approval as outlined at the end of this Annex. Taking due account of the complexity of the relevant New Service and its implementation by analysis, the following factors may determine the overall implementation timelines:

- 1 Changes required to the Access Provider's Network, including the extent of adjustments required to the existing Network assets, features, capabilities and services as well as any new assets, features, functionalities or technologies that will be required;
- 2 Any system requirements and its development including any new testing or repair or maintenance requirements;
- 3 Dependency on and liaison with external suppliers including their delivery timelines;
- 4 Impact on other Licensed Operators;

(the '**Timeline for Service Implementation**'); and

(iv) any other matters relevant to the New Service Order.

1.9 For the purpose of such detailed discussion, the Access Provider shall be obliged to provide reasonable support to the Access Seeker including offering the necessary meetings (whether face-to-face or virtual) to enable the Access Seeker to prepare and submit to the Access Provider a Statement of Requirements. To facilitate these discussions, the Access Seeker shall also be obliged to provide to the Access Provider any further information the Access Provider reasonably requires which will enable it to properly scope, develop, implement or supply the New Service including the preliminary forecasts as well as any technical, operational or other requirements.

1.10 Notwithstanding the above, the parties may, following the initial meeting, agree that due to the nature of the New Service Order by the Access Seeker, especially in what could reasonably be understood as a simple case, there is no need for a detailed discussion between the parties and the Access Seeker may proceed directly to submitting the Statement of Requirements. For the avoidance of doubt, such conclusion shall not be subject to a unilateral assessment of the Access Seeker only and should be subject to mutual agreement between the parties.

1.11 When the parties have concluded these preliminary discussions, and unless the Access Seeker decides against further pursuit of the New Service Order, the Access Seeker, shall submit to the Access Provider a comprehensive Statement of Requirement within a maximum of two (2) calendar weeks from the conclusion of discussions referred to in this clause 1.11, setting out in detail the proposed aspects of the New Service as identified in clause 1.8, which shall properly reflect the outcome of the detailed discussions between the parties. Where the contents of the Statement of Requirements in any material aspect

differ from the outcome of the detailed discussions between the parties, the Access Provider shall be entitled to seek clarifications from the Access Seeker within one (1) calendar week upon receipt of the Statement of Requirements, including requesting the Access Seeker to resubmit the relevant Statement of Requirements making the necessary changes, where required. Such resubmission, if applicable, must be made within one (1) calendar week of the Access Provider's request.

- 1.12 Subject to Clause 1.9, in the event the Access Seeker and the Access Provider cannot reach an agreement on a particular issue or issues to finalise the detailed Statement of Requirements, or its content does not satisfy the requirements stipulated in clause 1.8, the Access Provider shall return it to the Access Seeker for re-submission as envisaged in clause 1.11. If, after being returned by the Access Provider twice, any Statement of Requirements re-submitted by the Access Seeker does not satisfy the requirements stipulated in clause 1.8. or fails to reflect the detailed discussions between the Parties, the New Service Order process will be deemed to be at its end pursuant to clause 1.16.

Confidentiality

- 1.13 Unless instructed otherwise by the Access Seeker in writing, and until a detailed Statement of Requirements is completed and finally submitted to the Access Provider, the Access Provider shall not disclose any information on a New Service Order to any other Licensed Operator including its Affiliates or any third party, unless legally obliged to do so. Notwithstanding the above, the Access Provider shall be obliged to notify the receipt of any New Service Order to the ECTC and provide the ECTC with the information described in Clause 1.7(b).
- 1.14 The Access Provider shall not be required to seek consent from the Access Seeker for disclosing and/or sharing the Statement of Requirements finally submitted to it by way of Industry Consultation, or the subsequent TRA Consultation, as applicable. For the avoidance of doubt and unless the exception described below in this clause 1.14 applies, any Statement of Requirements submitted under this Reference Offer shall not be subject to the obligation of Confidentiality as per clause 20 (Confidentiality) Schedule 9 – Supply Terms, to the extent to which this is being shared with or disclosed to the ECTC or the TRA for the purposes described in this RO. However, this shall not prevent the Access Seeker from instructing, no later than at the time of submitting the Statement of Requirements, the Access Provider formally in writing that specific information in the Statement of Requirements provided by the Access Seeker shall be treated as confidential by the Access Provider and shall be, for the purpose of the Industry Consultation, omitted from the Statement of Requirements due to its commercial sensitivity for that particular Access Seeker, such as preliminary forecasts. The Access Seeker shall not be entitled to seek confidential treatment for any other parts of the Statement of Requirements which shall be subject to the Industry Consultation or the TRA Consultation, in particular the description of the New Service or any of its characteristics or price terms including the Timeline for Service Implementation. Following such written instruction from the Access Seeker, the

Access Provider shall be obliged to treat such information as confidential pursuant to clause 20 (Confidentiality) of Schedule 9 – Supply Terms, and shall remove (or redact) it from the relevant Statement of Requirements for the purposes of the Industry Consultation (and any subsequent TRA Consultation), as applicable.

- 1.15 Should the Access Seeker decide to discontinue pursuing a New Service Order or any Statement of Requirements including, without limitation, for reasons related to such Industry Consultation, it may withdraw its request at any time.

Discontinuation of discussions between the Access Seeker and the Access Provider.

- 1.16 The parties may consider the New Service Order process to be at an end, if:
- (a) matters discussed between them including all the terms of the Statement of Requirements and in particular the relevant commercial terms cannot be agreed within ninety (90) days of the receipt of the New Service Order, or any shorter period set out in the Law in respect of specific services; or
 - (b) there is no legal obligation on the Access Provider to provide the New Service; or
 - (c) without prejudice to any duty of confidentiality, the other party has failed to treat any information arising out of or in connection with the discussions between them as confidential, or
 - (d) the Access Seeker, which submitted the relevant New Service Order, failed to attend scheduled meetings, or to engage in discussions with the Access Provider, or provide the information necessary to progress with the New Service Order.
- 1.17 Discussions in relation to the supply of a New Service shall continue while the parties are engaged in any dispute resolution, provided that:
- (a) the Access Seeker demonstrates financial stability (failing which the continuation of negotiations shall be at the Access Provider's discretion); and
 - (b) the negotiations are strictly confidential and without prejudice to any ongoing dispute between the parties. For the avoidance of doubt, the parties agree that the negotiations, materials, documents and/or discussions, whether formal or informal, in relation to the New Service cannot be adduced as evidence as part of any ongoing dispute or used as a submission or part thereof for any ongoing dispute.

Industry Consultation

- 1.18 Once the Access Provider receives the final Statement of Requirements, which reflects the outcome of the detailed discussions between the parties, the Access Provider shall be obliged to refer the final Statement of Requirements to the ECTC within three (3) Working Days for the purposes of a consultation with the industry via the ECTC (the “**Industry Consultation**”).

1.19 The purpose of the Industry Consultation is to ascertain whether other Licensed Operators may be also interested in the New Service, consult all its parameters and the proposed commercial terms and seek advice from the experts with the ECTC so that the New Service can be delivered to the greatest benefit of the whole industry and consumers and not only the Access Seeker who initiated the New Service Order. The Industry Consultation and in particular any agreement reached with the ECTC may also provide direction regarding priority of New Service implementation especially where there are different New Service Orders, which compete for the same resources of the Access Provider or where the nature of such requests may require prioritisation of certain requests.

1.20 The Authority has the right to participate in the Industry Consultation, have access to the Statement of Requirements and any information or discussions held there as well as express its views on the New Service from the perspective of the regulator and the objectives it pursues.

Following the completion of the Industry Consultation, the Access Seeker may consider revising and resubmitting the Statement of Requirements where the Access Provider reasonably considers that the original Statement of Requirements no longer reflects the outcome of the Industry Consultation and requires amendments. The Access Seeker should make reasonable efforts to take account of the Industry Consultation and the views expressed therein. The Access Seeker is however not obliged to amend the Statement of Requirements against the version, which was subject to the Industry Consultation, if such amendment would prevent the Access Seeker from achieving the objective pursued by the New Service Order (and the corresponding Statement of Requirements). The Access Seeker shall be entitled to instruct the Access Provider to proceed to the next stage of the process (i.e., submission to the Authority and seeking its approval) if the Industry Consultation does take place (or conclude) within one month following the submission of the Statement of Requirements pursuant to clause 1.18.

Submission to the Authority and seeking the TRA approval of New Service and publication in the RO

1.21 Following the Industry Consultation, including any modifications to the Statement of Requirements to reflect its outcome if and where required, the Access Provider shall prepare:

- (a) detailed description of the New Service setting its final parameters in a format required for the amendment to any Service Description or any other Schedule or part of the latest version of this Reference Offer, and
- (b) a summary report on the outcome of the Industry Consultation and any advice from the ECTC, as applicable,

which the Access Provider shall, within a reasonable timeline taking into account the scope of the NSO and the extent of changes to the Reference Offer triggered by it, submit

to the Authority requesting the Authority's approval of the corresponding amendment to the Reference Offer.

- 1.22 Upon the TRA's approval of the relevant amendment to the Reference Offer, the Access Provider shall:
- (a) Publish the amended Reference Offer; and
 - (b) start offering the New Service to any Licensed Operators from the date of the publication of the amended Reference Offer respecting the relevant Timeline for Service Implementation reflecting the outcome of the Industry Consultation, as applicable.

Development of a New Service Initiated by the Access Provider

- 1.23 The Access Provider shall endeavour to identify on non-discriminatory basis opportunities for developing New Services based on its experience with providing existing Services, feedback from and suggestions raised by the Licensed Operators. as well as any gaps or other possibilities for improvement, needs of the industry and the economy of the Kingdom of Bahrain. This includes, without limitation, introducing additional terms, enhanced service levels, where appropriate, and more flexible pricing arrangements.
- 1.24 When the Access Provider identifies such opportunity, it shall use internal governance processes to engage in and complete an initial assessment to ascertain its feasibility and estimate, on preliminary basis, the implementation costs and the market potential for such New Service, as and where applicable. This shall follow the requirements for a New Service Order as described above in 1.8 including preparing and submitting a Statement of Requirements including making such Statement of Requirements subject to 1.6the Industry Consultation.

ANNEX 2 – NEW SERVICE ORDER

For placing a New Service Order, the Access Seeker shall use the following form:

To: BAHRAIN NETWORK (BNET) B.S.C (CLOSED)

From: *[Insert name]* (the “Requesting Operator”)

Date: *[Insert date]*

NEW SERVICE ORDER IN RELATION TO THE ACCESS PROVIDER’S REFERENCE OFFER

1. Does the New Service Order relate to (i) an existing Service or (ii) involves request for a completely new Service?

[Please provide an answer]

2. Does the service satisfy the requirements for a Service under the present Reference Offer? Please explain the basis on which the Requesting Operator considers that this is the case.

[Please provide an answer]

In addition, please provide the following:

- (a) reasonably detailed description of the proposed New Service:

.....

- (b) an outline of the technical, operational and functional specifications which the Requesting Operator considers should apply to the New Service:

.....

- (c) the Requesting Operator’s opinion of the likely interest in and uptake of the New Service in general, its benefits to the end users, including a preliminary forecast of the Requesting Operators’ expected use of the New Service:

.....

- (d) the Requesting Operator’s assessment as to why the current Services in the Reference Offer do not satisfy their requirements:

.....

SIGNED by [insert name of REQUESTING OPERATOR]:

.....

Signature of the Requesting Operator's Authorized Representative

.....

Name of the Requesting Operator's Authorised Representative (print)

Please note that unless expressly instructed otherwise in writing, the Access Provider shall consider the present New Service Order as confidential subject to any exception as described in Schedule 1, Annex 1 (New Service Order Process) of the reference Offer.

SCHEDULE 2 – NOTIFICATION AND ACCEPTANCE OF SERVICE ORDER

SERVICE ORDER

1. Following the execution of the Agreement between the Parties, the Access Seeker shall be entitled to submit to the Access Provider a Service Order. The submission of a Service Order shall follow the process described in this Schedule, the business process for fulfilment and assurance as described in the relevant Operations Manuals (appended to Schedule 6). The actual submission of a Service Order by the Access Seeker to the Access Provider shall be made using the method made available from time to time by the Access Provider making use of an order management system or service portal or any other established or standard means of automated communication as may be communicated to the Licensed Operator by the Access Provider in writing.
2. Unless the Agreement provides otherwise, the Access Provider shall not be obliged to process any other submissions of the Access Seeker, which are not properly constituted Service Orders.
3. The Access Seeker's Service Order must contain:
 - (a) the list of Services requested using the categories, subcategories or other classification used for the Service in the relevant Service Schedule (Schedule 6). If there is any doubt, the Access Seeker shall consult with the Access Provider before submitting a Service Order;
 - (b) type of Licence held by the Access Seeker to ascertain eligibility of the Access Seeker for certain categories of Services covered by the Service Order, if applicable;
 - (c) the Access Seeker's designated contact person, and their contact details.

By submitting any Service Order, the Access Seeker represents and warrants to the Access Provider, that the information provided in its Service Order is complete, true, accurate, and not otherwise misleading.

NON-CONFORMITY AND REJECTION OF A SERVICE ORDER

4. The Access Provider shall consider a Service Order to be non-conforming with this Reference Offer where:
 - (a) there is no Agreement in place between the Parties or it has been suspended, terminated, or expired; or
 - (b) the Access Seeker is not a Licensed Operator or does not hold an appropriate Licence; or
 - (c) the services requested are not Services; or
 - (d) any of the mandatory information required under clause 3 above is unclear, illegible, inaccurate, invalid, or conflicting or cannot reasonably be understood; or
 - (e) the Access Seeker has not provided adequate information under clause 3 above, or

- (f) was submitted or processed by the Access Seeker in error.
- 5 The Access Provider is entitled to reject a Service Order, if:
- (a) the applicable law, the Authority or other competent authority order or a Force Majeure Event prevents the Access Provider from processing the Service Order for more than 30 Calendar Days, or;
 - (b) the Access Seeker committed a Material Breach of the Agreement, and the Access Provider exercised its right to Suspend this Agreement or the particular Service, or
 - (c) or any other reason as specified in the relevant service description in Schedule 6.
6. If the Access Provider finds a Service Order to be non-conforming under clause 5 or there is another reason stipulated under clause 6, it shall:
- (a) notify the Access Seeker in writing within the timescales specified in Schedule 7 (Service Levels), if applicable;
 - (b) at the time of rejection, provide sufficiently detailed reasons for rejection to the Access Seeker; and
 - (c) not be required to process the Service Order without any liability on its part.
7. The Access Provider may in its sole discretion elect to accept any Service Order notwithstanding that there is any defect in that Service Order if the Access Provider considers that such defect does not have a material effect on the Access Provider's ability to process the Service Order and provide the respective Service.
8. Notwithstanding the above, nothing prevents the Access Seeker from re-submitting a Service Order provided that the Access Seeker is able to remedy its original non-conformity or defect or where the reasons or circumstances preventing the Access Provider from processing the Service Order are no longer applicable.

ACCEPTANCE OF A SERVICE ORDER

9. Following acceptance of a Service Order, the Access Provider shall send the Access Seeker an acknowledgement of the Service Order within the time periods stipulated in Schedule 7 (Service Levels), as applicable, or within the time period that apply to a specific Service as per the respective Schedule 6 (Service Descriptions), as applicable.
10. Following such acceptance, the Access Provider shall process, subject to the exceptions, limitations and conditions specified in this Reference Offer, the Service Order without delay and deliver the Service on or before the RFS Date and/ or in accordance with Schedule 7 – (Service Levels) of the Reference Offer, as applicable. The Access Seeker acknowledges and agrees that this involves the Access Provider incurring costs and engaging internal and external resources in order to fulfil its supply obligations.

11. As a result, after acceptance and acknowledgement of any Service Order by the Access Provider, the Access Seeker is deemed to have firmly committed to accept the Service following its delivery and completion by the Access Provider and pay all applicable Charges. For avoidance of doubts, after such date, and unless provided otherwise in the Agreement, the Access Seeker shall not be entitled to request any suspension, delay, invalidation, discontinuation or withdrawal of the Service Order.

12. Notwithstanding the above, the Access Seeker may request a cancellation of a Service Order following its acknowledgement by the Access Provider up to the relevant RFS date, subject to a payment of a relevant Charge as stipulated in Schedule 3 (Pricing).

SCHEDULE 3 – PRICING

1A – MOBILE DATA SERVICE

A. Managed MDS (MDS-M)

MONTHLY RECURRING CHARGES

Bandwidth (Mbit/s)	MDS-M Connection Monthly Recurring Charge (BD)	Monthly Recurring Charge (BD) Volume Discount (in total equal or above 400) **
500	252.00	201.6
1,000	290.00	232
1,500	441.00	352.8
2,000	516.60	413.28
2,500	585.00	468
5,000	750.00	600
10,000	850.00	680

* Temporary MDS-M Service shall be charged at 50% mark-up on the requested bandwidth.

** To qualify for this volume discount, the following conditions must be met:

1. The relevant Access Seeker has existing and active MDS-M Service Connection and/ or Service Orders placed for MDS-M Connection, which in total equal to or exceed 400 (as further described below) and this volume discount threshold of 400 in total must be maintained at all times; and
2. With the exception of MDS-M Service Orders placed after the date of approval of the current Reference Offer, only existing and active MDS-M Service Connections that are under a Minimum Service Period of 24 months qualify for the purpose of application of this volume discount. For avoidance of doubts, any existing and active MDS-M Service Connection that are not under a Minimum Service Period of 24 months, would not be taken into account.

Notwithstanding the provisions governing Minimum Service Period or Renewed Minimum Service Period, respectively, as set out in Schedule 6.3 (MDS-M), the Access Seeker may, within two weeks following the date of approval of the current Reference Offer (i) place Service Orders for new MDS-M Connection(s) and (ii) renew the Minimum Service Period for any existing and active MDS-M Service Connections in order for these Connections to be under a new Minimum Service Period of 24 months, in which case (i) all Service Orders for new MDS-M Connection(s) and (ii) all the existing and active MDS-M Service Connections for which the Access Seeker renewed their Minimum Service Period within these two weeks, would qualify for this volume discount, and the relevant Access Seeker will benefit from this volume discount from the date of the approval of the current Reference Offer.

Such new (or renewed) Minimum Service Period will be considered as a 'Minimum Service Period' pursuant to Schedule 6.3 (MDS-M).

AGGREGATION LINKS FOR MDS-M SERVICES

Bandwidth (Mbit/s)	Monthly Recurring Charge (BD)
10 Gbit/s aggregation link	4x aggregations free of cost and additional aggregations will be charged according to the defined charges for 10 Gbit/s
10 Gbit/s aggregation link	450.00
100 Gbit/s aggregation link	718.150

NON-RECURRING CHARGES

Chargeable Activity	Charge (BD)	Charge Basis
MDS-M installation and configuration charge for MDS-M Connection or MDS-M Aggregation Link	400.00	Per connection
MDS-M Upgrade/Downgrade for MDS-M connection or MDS aggregation (Hard Change)	400.00	Per connection Per "hard" change. Applies when new Network equipment is required such as new cable access, new network port and/or new CPE (e.g. add a Connection or add an additional Aggregation Link or increase/decrease in bitrate of a connection). Include all the work required (e.g. the physical installation and configuration at both ends).
MDS-M Downgrade/Any configuration change for MDS-M connection or MDS-M aggregation (Soft Change)	50.00	Per connection Applies when no new Network equipment is required (for example, increase or decrease in the bitrate of a Connection or any configuration change in the connection).

B. Mobile Data Service – Unmanaged (MDS-U)

MONTHLY RECURRING CHARGES

MDS-U	Charge (BD)	Charge Basis
Use of a single fibre pair	0.249	Per metre/fibre pair/month (total distance per each MDS-U Connection corresponding to the actual fibre pair distance)

Minimum Service Period of 24 months

NON-RECURRING CHARGES

Chargeable Activity	Charge (BD)	Charge Basis
Processing application fee	100.00	Per each application on a single Connection basis
Reprocessing fee	50.00	Per each resubmission or amendment of each original application on a single Connection basis
Excess Construction Charges	Where all cost of work and material to establish a particular Connection exceed the corresponding MRC for 48 months*	Time and Material basis as set out in Annex 1 corresponding to the costs exceeding an amount corresponding to the MRC for 48 months
Field study, if required	0.430 per meter of the fibre pair route	Distance of the fibre pair route
Relocation (Internal & External)	Cost of work and material	Time and Material basis as set out in Annex 1
Procurement and connection of Mobile Network Equipment by the Access Provider (at Access Seeker's choice)	Cost of work and material	Time and Material basis as set out in Annex 1

* Whilst the Access Provider will endeavour to provide the Unmanaged MDS across the territory of the Kingdom, there may be instances where the cost of a particular Connection will be excessive (i.e., the overall costs will exceed the corresponding MRC for 48 months). In such case, instead of covering the Excess Construction Charges, the Access Seeker may offer and agree with the Access Provider to extend the Minimum Service Period accordingly. For early termination of a Connection covered by such extended Minimum Service Period, the relevant provision of the MDS-U Operational Manual for calculating liquidated damages shall apply mutatis mutandis.

1B – WHOLESALE DATA CONNECTION (WDC)**MONTHLY RECURRING CHARGES**

Bandwidth	WDC Connection Monthly Recurring Charge (BD)
64 Kbit/s	52.66
128 Kbit/s	54.87
256 Kbit/s	58.14
512 Kbit/s	60.93
1 Mbit/s	66.42
2 Mbit/s	77.67
4 Mbit/s	121.41
8 Mbit/s	147.15
10 Mbit/s	157.77
15 Mbit/s	180.81
20 Mbit/s	200.79
25 Mbit/s	218.88
50 Mbit/s	292.86
75 Mbit/s	313.47
100 Mbit/s	313.47
150 Mbit/s	365.22
200 Mbit/s	400.77
300 Mbit/s	479.16
400 Mbit/s	541.35
500 Mbit/s	597.87
622 Mbit/s	661.32
750 Mbit/s	731.97
1 Gbit/s	842.49
1.25 Gbit/s	943.20
1.5 Gbit/s	1,036.80
2 Gbit/s	1,208.61
2.5 Gbit/s	1,365.48
5 Gbit/s	2,160.18
7.5 Gbit/s	2,708.82
10 Gbit/s	3196.17
25 Gbit/s	4,000.00
50 Gbit/s	5,000.00
100 Gbit/s	12,406.00
1 Gbit/s aggregation link	180.00
10 Gbit/s aggregation link	450.00

Bandwidth	WDC Connection Monthly Recurring Charge (BD)
100 Gbit/s aggregation link	1,746.280

** Point to Point WDC connectivity between two End Users of an Access Seeker shall be charged at 50% premium on the MRC of the requested bandwidth.*

** Temporary WDC Service shall be charged at 50% mark-up on the applicable MRC for the relevant bandwidth. However, the Charge for any Temporary WDC Service where the Temporary Service Period is below one full month, shall equal to the Charge applicable for a full month.*

1C – WHOLESALE DATA CONNECTION (WDC)

MONTHLY RECURRING CHARGES – 3+ YEARS CONTRACT PERIOD DISCOUNT

Bandwidth (Mbit/s)	Monthly Recurring Charge (BD) Discount for 3+ Years Contract period WDC Connection
100 Mbit/s	250.776
150 Mbit/s	292.176
200 Mbit/s	320.616
622 Mbit/s	529.056
1 Gbit/s	673.992
10 Gbit/s	2,556.936
25 Gbit/s	3,200.00
50 Gbit/s	4,000.00
100 Gbit/s	9,925.568

* Point to Point WDC connectivity between two End Users of an Access Seeker shall be charged at 50% premium on the MRC of the requested bandwidth.

NON-RECURRING CHARGES

Chargeable Activity	Charge (BD)	Charge Basis
Installation and configuration charge for WDC Connection or WDC Aggregation Link	400.00	Per connection
Downgrade/ any configuration change for WDC connection or WDC aggregation (Soft Change)	50.00	Per Connection. Applies when no new Network equipment is required (for example, increase or decrease in the bitrate of a Connection or any configuration change in the connection). Includes the CPE configuration at both ends.
Upgrade/Downgrade for WDC connection or WDC aggregation (Hard Change)	400.00	Per "hard" change. Applies when new Network equipment is required such as new cable access, new network port and/or new CPE (e.g. add a Connection or add an additional Aggregation Link or increase/decrease in bitrate of a connection). Include all the work required (e.g. the physical installation and configuration at both ends).

Time and Material	Charges based on Time and materials work as referred to Annex 1 of Schedule 3	The necessity of all work chargeable on a time and materials basis.
-------------------	---	---

CHARGES FOR WDC PROTECTION RETAINED UNDER THE PREVIOUS VERSION OF THE REFERENCE OFFER

Any particular WDC Connection for which the Access Seeker requested and the Access Provider provided an end-to-end physical and logical protection before the effective date of the current Reference Offer (or its approval or issuance by the TRA, as applicable) shall continue benefitting from the same Charge for such additional protection (i.e., 30% premium on top of the applicable MRC for the relevant WDC Connection per month) as was applied before the effective date of this Reference Offer, until ceased by the relevant Access Seeker.

1D – WHOLESALE BITSTREAM SERVICE (WBS)

MONTHLY RECURRING CHARGES

A. WBS ESSENTIAL SERVICE

Bandwidth (Contention ratio 15:1)	WBS Connection Monthly Recurring Charge (BD)
Voice only	0.928
300 Mbit/s downstream / 60 Mbit/s upstream	7.02
500 Mbit/s downstream / 250 Mbit/s upstream	16.14
750 Mbit/s downstream / 375 Mbit/s upstream	21.52
1 Gbit/s downstream / 500 Mbit/s upstream	32.28
2 Gbit/s downstream / 1 Gbit/s upstream	50.40

B. WBS ADVANCED SERVICE

Bandwidth (Contention ratio 8:1)	WBS Connection Monthly Recurring Charge (BD)
Voice only	1.728
300 Mbit/s downstream / 150 Mbit/s upstream	25.00
500 Mbit/s downstream / 350 Mbit/s upstream	35.00
750 Mbit/s downstream / 525 Mbit/s upstream	50.00
1 Gbit/s downstream / 1 Gbit/s upstream	95.00
2 Gbit/s downstream / 2 Gbit/s upstream	147.00

AGGREGATION LINKS FOR WBS SERVICES

Bandwidth (Mbit/s)	Monthly Recurring Charge (BD)
First Single 10 Gbit/s Aggregation Link*	Charge included in MRC
Any additional 10 Gbit/s Aggregation Link (on request)	358.50
100 Gbit/s Aggregation Link (on request)	1,200.00

*The first single 10 Gbits/s WBS aggregation link is included in MRC.

Multiple free of charge 10 Gbits/s links cannot be availed by the same Access Seeker.

ADDITIONAL CHARGES WBS

Chargeable Activity	Charge (BD)	Charge Basis
Agreement processing and service setup fee for establishing WBS Service	1,419.00	One-off
Charges for rejections, reversals, internal relocation, or withdrawals associated with the WBS Service Order	5.00	Per event
Charges for a change of bandwidth (downgrade)	10.00	Per event
External relocation charge	10.00	Per event
Port Cessation Charge	10.00	Per event
Port Cessation Charge During WBS Transfer	10.00	Per event (Charged to Gaining Retail Service Provider, the 'GRSP')
Activation of Integrated ONT	5.00	Per activation
Appointment Rescheduling (past the point of no return)	5.00	Per Event
Charges for a call out for a technician on Access Seeker's request	Time and materials in accordance with Annex 1	Per event
Fault handling (non-BNET responsibility)	Time and Materials in accordance with Annex 1 (e.g. Cost of ONT, Cost of Patch Cord, Cost of Fiber Termination Box) Engineer Visit 20.00	Per Event
Charges for suspension of WBS at Access Seeker's request	5.00	Per act of suspension and each connection
Connection Charge	20.00	One-off (if applicable, charged to GRSP for WBS Transfer Request when it requires a visit)
Premium Service Delivery Charge	50.00	One-off per connection (i.e., not applicable on top of the standard Connection Charge above)
Change request	Per event Charges will be provided based on the requirement (e.g., additional VLAN configuration)	<ol style="list-style-type: none"> 1. Additional VLAN. 2. VLAN shift from aggregation to another. 3. Change in agreed LAN profile. 4. Change on VAS profile. 5. Temp VLAN. Shifting Aggregation and migration

MONTHLY RECURRING CHARGES FOR COPPER-BASED WBS SERVICES

The Access Seeker shall be allowed to continue using the copper-based WBS Connections as of the effective date of this Reference Offer, at the Charges as described in this section below, until the migration to fibre infrastructure.

For avoidance of doubts, these copper- based WBS Services shall not be available for any new Service Orders after the effective date of this Reference Offer.

Once the fibre becomes available for the relevant WBS Connection, it shall be migrated to the available fibre-based WBS Service of at least the minimum bandwidth available at the time, or any higher bandwidth as per the choice of the Access Seeker.

A. FORMER WBS RESIDENTIAL (AS PER THE PREVIOUS REFERENCE OFFER)

Bandwidth (Contention ratio 15:1)	WBS Connection Monthly Recurring Charge (BD)
Voice only	0.928
1.024 Mbit/s downstream / 512 Kbit/s upstream	2.90
2.048 Mbit/s downstream / 1.024 Mbit/s upstream	4.14
3.072Mbit/s downstream / 1.024Mbit/s upstream	4.50
4.096Mbit/s downstream / 1.024Mbit/s upstream	4.86
6.144Mbit/s downstream / 1.024Mbit/s upstream	5.58
8.192Mbit/s downstream / 2.048Mbit/s upstream	6.30
10.240Mbit/s downstream / 2.048Mbit/s upstream	7.02
16.384Mbit/s downstream / 2.048Mbit/s upstream	9.18
20Mbit/s downstream / 2.048Mbit/s upstream	10.04

B. FORMER WBS NON-RESIDENTIAL (AS PER THE PREVIOUS REFERENCE OFFER)

Bandwidth (Contention ration 8:1)	WBS Connection Monthly Recurring Charge (BD)
Voice only	1.728
256Kbit/s downstream / 64Kbit/s upstream	3.50
512Kbit/s downstream / 256Kbit/s upstream	3.75
640Kbit/s downstream / 256Kbit/s upstream	3.84
1.024Mbit/s downstream / 512Kbit/s upstream	4.68
2.048Mbit/s downstream / 1.024Mbit/s upstream	4.77
4.096Mbit/s downstream / 1.024Mbit/s upstream	6.99
6.144Mbit/s downstream / 1.024Mbit/s upstream	8.54
8Mbit/s downstream / 2Mbit/s upstream	10.09
10.240Mbit/s downstream / 2.048Mbit/s upstream	11.63
16.384Mbit/s downstream / 2.048Mbit/s upstream	16.27
20Mbit/s downstream / 4.048Mbit/s upstream	21.52

1E – CORE CONNECT AND LANDING STATION SERVICE (CCLS)

MONTHLY RECURRING CHARGES

Signal/ Bandwidth	CCLS Monthly Recurring Charge (BD)
5 Gbit/s	950.00
OTU2/10GE	1,500.00
25 Gbit/s	2,750.00
OTU3/ 40GE	3,300.00
50 Gbit/s	4,000.00
OTU4/ 100GE	6,300.00

NON-RECURRING CHARGES

Chargeable Activity	Charge (BD)	Charge Basis
Installation and configuration charge for CCLS Connection	400.00	Per each CCLS Connection
Downgrade or any configuration change for CCLS connection (Soft Change)	50.00	Per Connection. Applies when no new Network equipment is required (for example, decrease in the bitrate of a Connection or any configuration change in this Connection). Includes the CPE configuration at both ends.
Upgrade/Downgrade for CCLS Connection (Hard Change)	400.00	Per Connection. Applies when new Network equipment is required including but not limited to new cable access, new network port and/or new CPE (e.g. add a Connection or increase/decrease in bitrate of a connection). Includes all the work required (e.g. the physical installation and configuration at both ends).
Time and Material	Charges based on Time and materials work as referred to Annex 1 of Schedule 3	The necessity of all work chargeable on a time and materials basis.

1F – FIBER FRONTHAUL SERVICE (FFS)

CHARGES FOR FFS RETAINED UNDER THE PREVIOUS VERSION OF THE REFERENCE OFFER

Any FFS Connection provided by the Access Provider to the Access Seeker before the effective date of the current Reference Offer dated 9 October 2024¹ shall continue benefitting from the same Monthly Recurring Charges and the charging basis (as well as any other applicable charges) as was applied before the effective date of this Reference Offer, until ceased by the relevant Access Seeker.

For avoidance of doubts, FFS shall not be available for any new Service Orders after the effective date of this Reference Offer (i.e., 9 October 2024) and the Access Seeker may order an Unmanaged MDS.

MONTHLY RECURRING CHARGES

Chargeable Activity	Charge (BD)	Charge Basis
Fibre cable route	0.189	Per metre/fibre cable/month (total distance per each FFS Connection corresponding to the actual fibre cable route distance)

NON-RECURRING CHARGES

Chargeable Activity	Charge (BD)	Charge Basis
Processing application Fee	100.00	Per application
Reprocessing Fee	50.00	Per resubmission or amendment of original application
Make Ready and installation Charges	Cost of work	Time and Material basis as set out in Annex 1
Field study, if required	For the Field study, charge 0.430 per meter of the actual fibre cable route	Time and Material basis as set out in Annex 1

¹ See Telecommunications Regulatory Authority of the Kingdom of Bahrain Consultation Report and Regulatory Decision dated 9 October 2024 LAD 1024 057

1G – SP - ACCESS

Chargeable Activity	Charge (BD)	Charge Basis
Processing application Fee	100.00	Per application
Site Survey, if required (only chargeable in case of 24 months Minimum Service Period)	For fibre cable pair rental, the field study total charge 0.430 per meter of the fibre cable route	Time and Materials
Reprocessing Fee	50.00	Per resubmission or amendment of original application
Access Site Lease Administrative Charge	200.00	Per lease processed
Make Ready and installation charges	Cost of work	Time and Material basis as set out in Annex 1
Site Space Charge (other than SNFM Service) - including power supply limited to 3 kw/ month	100.00	Per square metre/Site/month for space occupied or rendered unusable
Fibre cable pair rental for the use of the fibre cable pair including the associated passive infrastructure (which is not charged separately)	0.189	Per meter/per fibre cable pair/ month In case of Minimum Service Period of 60 months, the fibre cable material and installation by BNET is included in the Charge for the Fibre cable pair rental and shall not be charged separately. In case of Minimum Service Period of 24 months, the charge for fibre cable material and installation will be provided as part of the BNET's proposal.
Additional Power Supply or other Equipment Request Charge	On application	On application
Security and Site Access Administration Fee	5.00	Per staff access card/per site/per month
Scheduled installation, maintenance and removal Charges (Working Hours)	14.00	Per hour (two hour minimum call out)
Scheduled installation, maintenance and removal Charges (Out of Working Hours)	21.00	Per hour (two hour minimum call out)
Unscheduled installation, maintenance and removal Charges (Urgency Surcharge)	36.00	Per hour (two hour minimum call out)
Additional Requested Services	Cost of work	Time and Material basis as set out in Annex 1

1H – SERVICE NODE FACILITIES MANAGEMENT SERVICE

Chargeable Activity	Charge (BD)	Charge Basis
Processing Access Application Fee	100.00	Per Application
Reprocessing Fee	50.00	Per resubmission or amendment of application
Co-location Fee	350.00	Per rack per month
Security ID Cards Charge	5.00	Per ID Card per month
Escorted planned normal working hours	21.00	Per hour
Escorted planned outside working hours	29.00	Per hour
Escorted unplanned normal working hours	30.00	Per hour
Escorted unplanned outside working hours	41.00	Per hour
Additional Power Charge	300.00	Per kW per year
Tie Cable rental charge	25.00	Per cable per month

1L – NETWORK RIGHT OF USE (NRU) SERVICE

Chargeable Service or Activity	Frequency	Charge in Bahraini Dinars (BHD)	Charge Basis
NRU Service	Monthly rental charge	0.249	Per metre of Fibre Capacity per month (The calculation shall be made on the total distance of the Fibre Capacity in meters as per the figure stipulated in the individual ATA and shall be fixed during the entire NRU Term). ¹
Scheduled repair, maintenance, installation/ replacement, (Business Hours)	Per activity	14	Per hour (minimum chargeable unit is two hours)
Scheduled repair, maintenance, installation/replacement, (Out of Hours)	Per activity	21	Per hour (minimum chargeable unit is two hours)
Unscheduled repair, maintenance, installation/replacement, (Urgency Charge)	Per activity	36	Per hour (minimum chargeable unit is two hours)
Any additional maintenance services or materials that may be requested by the Access Seeker	Per activity	To be calculated on a time and materials basis	Time and materials (Annex 1)

¹ The Access Seeker and Access Provider acknowledge that the length of Fibre Capacity being provided under this Schedule 6.8 is the subject of a separate ATA entered into between the parties. Accordingly, the Access Seeker shall not be entitled, during the entire NRU Term, to raise any Billing Dispute related to the distance of the Fibre Capacity (as long as the length quoted by the Access Provider in its invoices of the NRU Services is identical to that set out in the respective ATA). All other Billing Disputes that may arise in relation to this NRU Service may be raised pursuant to Schedule 4 (Billing).

SCHEDULE 3

ANNEX 1 – RATES FOR TIME AND MATERIALS WORK

Chargeable Activity	Charge (BD)	Charge Basis
Time-based work	20.00	Per hour, subject to minimum of: Four hours for construction work; Two hours for maintenance work; One hour for clerical work; and Two hours for any other work
Materials	Cost plus a fair and reasonable margin	Per item, margin to be assessed and agreed on a case by case basis

SCHEDULE 4 – BILLING

1. Charging Principles

- 1.1 Charges for the Services provided under the Reference Offer by the Access Provider (including any Charges for the installation of any equipment, apparatus, or other material in relation to the Services as well as any chargeable activity or work conducted by the Access Provider under the terms of the Agreement) will be invoiced and paid according to the principles and procedures defined in this Schedule 4 – Billing, unless different principles and procedure are otherwise specified in the specific Service Description and/or the respective Operations Manual.
- 1.2 Payment of undisputed amounts in any Invoice is fundamental to the provisioning of Services by the Access Provider to the Access Seeker. Any failure to pay undisputed amounts by the Access Seeker on or by the Due Date in accordance with the Billing Period (as further defined below) will be considered as a Material Breach of the Access Seeker's obligations under the Agreement.

2. Charging and invoicing

- 2.1 The Access Provider (the "**Billing Party**") shall invoice the Access Seeker (the "**Billed Party**") for Services in accordance with the rates, principles or mechanisms for the calculation of the amount of Charges as set out in this Schedule and in Schedule 3 – (Pricing), or any other Charges applicable to the specific Services which may be set out in the Service Descriptions, of the Reference Offer.
- 2.2 For each Service or a Connection, as applicable, charging shall commence upon the Actual RFS Date.
- 2.3 Where the delivery of the Service ordered by the Billed Party and in particular but without limitation any new Service activation, is unreasonably delayed by or for reasons on the side of the Billed Party, the Billing Party shall be entitled to:
 - i. Invoice the Billed Party for any applicable Non-Recurring, Additional or other Charges, following either (i) the date that corresponds to the latest delivery or RFS Date corresponding to the relevant service level stipulated in Schedule 7 (Service Levels), or (ii) another date that have been agreed with the Billed Party as the RFS Date or a delivery date pursuant to the Agreement, if applicable; and
 - ii. Start invoicing the Billed Party for the applicable Recurring Charges following expiry of two (2) calendar months after the date mentioned in this Clause 2.3i) above, unless the respective Service Order has been cancelled by the Billed Party pursuant

to this Agreement. For avoidance of doubts, this clause excludes the possibility of applying Clause 5 (Billing in case of Service Order suspension) to the same Service Order or its part.

2.4 Where justified by objective technical reasons to be demonstrated by the Billed Party, the Billing Party and the Billed Party may agree that the Billing Party will be charging and billing the Billed Party for the final Service type to be delivered once the Billed Party is technically ready for it, whereas the Billing Party will in the meantime provide a temporary solution based on another Service type (e.g., the Billing Party will provide ten (10) 1Gbps links as a temporary solution which will be eventually replaced by one 10Gbps link as the final solution once the Billed Party is technically ready for using the 10 Gbps link). This is subject to the commitment by the Billed Party to move to such final Service type within a specific timeline as will be agreed between the Parties and which shall not exceed 12 months. The Billing Party shall be entitled to request a minimum term commitment for such final Service type to cater for the difference in any applicable Charges, which shall not exceed 24 months. As soon as agreed, any such arrangement must be made available and transparently communicated to all Licenced Operators via the ECTC or otherwise.

3. **Billing for Recurring Charges**

3.1 Recurring charges for Services will be payable in advance on a monthly basis (the “**Billing Period**”). Charges for the first month in which a Service is supplied to the Billed Party shall be pro-rated from the Actual RFS Date to the end of the first month in which the Actual RFS Date occurred.

3.2 The Billing Party shall issue to the Billed Party during the Calendar Month preceding the commencement of each Billing Period, an Invoice in electronic form (i.e., PDF or another form as may be agreed in writing by the Parties from time to time).

4. **Billing for Non-Recurring, Additional or other Charges**

4.1 Invoice for Non-Recurring, Additional or other Charges will be sent within 30 Calendar Days from the Actual RFS Date for the respective Service.

4.2 The Non-Recurring, Additional or other Charges related to Services supplied or any activity or work provided by the Billing Party to the Billed Party, shall be invoiced within 30 Calendar Days of all Services supplied, activities completed and/ or, where applicable, handed over to the Billed Party, in the preceding month.

4.3 The Charges that are payable by the Billed Party due to termination, cessation or cancellation of a particular Service, shall be invoiced and payable upon occurrence of each such event which gives rise to such payment obligation. The Billing Party shall provide the Billed Party with an Invoice for payment within 30 Calendar Days following occurrence of any such event.

5. Billing in case of Service Order suspension

- 5.1 The Billed Party shall be entitled to request in writing the Billing Party to suspend processing of a particular Service Order (and the delivery of the specific Service covered by it) following its submission to the Billing Party subject to the following:
- i. The request for suspension in writing is submitted to the Billing Party before the relevant RFS Date; and
 - ii. The period of suspension does not exceed two (2) months; and
 - iii. The request for suspension in relation to a particular Service Order or any Connection covered by it can be made only once.
- 5.2 Any Service Order suspended for the period that does not exceed two months pursuant to Clause 5.1 above shall not be, during such suspension period, subject to any applicable Charges provided that the Billed Party, prior to the expiry of such suspension period, requests in writing the Billing Party to complete the Service Order and activate the relevant Service. Billing of the Service Order shall begin on the Actual RFS Date.
- 5.3 During the suspension, the Billed Party may decide to cancel the Service Order completely, in which case the Billed Party shall submit a Cancellation Request in writing to the Billing Party before the expiry of the suspension period of two months. Such cancellation will be subject to the corresponding Cancellation Charge as stipulated in Schedule 3 – (Pricing).
- 5.4 In case the Access Seeker fails to submit (i) a written request to complete the delivery of the Service Order suspended pursuant to Clause 5.1 above or (ii) a Cancellation Request as per Clause 5.3 above, prior to the expiry of the suspension period, the Service Order shall be deemed cancelled and the Access Seeker shall be obliged to pay the cost incurred by the Access Provider in processing the Service Order until that date.

6. Issuing Invoices

- 6.1 The Billing Party shall provide the Billed Party with an Invoice setting out the Charges payable by the Billed Party in respect of the relevant Billing Period.
- 6.2 Unless mutually agreed otherwise, the Billing Party shall deliver each Invoice by e-mail to the Billed Party's Billing Representative. For this purpose, the Billed Party shall provide the Billing Party with the relevant email ID(s) of its Billing Representative. A delivery of the Invoice sent by e-mail shall be deemed received by the Billed Party if the Billing Party receives, at least an automatic system generated email receipt or confirmation.
- 6.3 The Billing Party shall ensure that all Invoices comply with the following requirements and include the following information:
- a. all amounts are stated in Bahraini Dinars;
 - b. total amount without the VAT including information as to which part is subject to the VAT;
 - c. the VAT Amount at the rate applicable at the time;

- d. total amount including the VAT Amount payable by the Billed Party;
- e. each Invoice has an Invoice unique reference number;
- f. the name and address of the Billing Party;
- g. the Due Date for payment and the time limits for raising any Billing Dispute;
- h. the available payment methods;
- i. bank details of the Billing Party;
- j. any mandatory information stipulated by the applicable law,
- k. sufficient information to enable the Billed Party to verify the amount of the Charges specified in the Invoice, including an itemised breakdown of the individual Services and Charges covered by the Invoice.

An Invoice cannot be rejected for formatting reasons, if all information above is provided in the Invoice.

- 6.4 The Billing Party shall be obliged to use all reasonable endeavours to issue accurate and complete Invoices to avoid unnecessary Billing Disputes.

7. Payment

- 7.1 The Billed Party must pay the amount mentioned on any Invoice in respect of which no Billing Dispute is raised by the Billed Party within the Billing Dispute Notification Period, by the Due Date. For the avoidance of doubt, the Billed Party must pay this amount to the Billing Party regardless of whether the Billed Party has received payment from its Customers or any third parties.
- 7.2 All payments must be:
- (a) made by electronic funds transfer directly to the nominated account of the Billing party, or by such other means as may be agreed by the Parties; and
 - (b) subject to clause 7.7, made without any set-off or counterclaim and free of any withholding or deduction, unless otherwise agreed by the Parties in writing; and
 - (c) made against a specific Invoice issued by the Billing Party using a unique Invoice reference number as provided by the Billing Party and the Billed Party shall provide the unique Invoice reference number in the payment confirmation to the Billing Party.
- 7.3 Payments are deemed to be received on the date the electronic funds are cleared in the Billing Party's bank account, unless the payment is subsequently dishonoured, in which case payment is deemed not to have been received until cleared funds are received by the Billing Party that are net of any associated bank charges or transfer fees, together with any dishonour fees and other related charges.

- 7.4 For any payment made by the Billed Party, which fails to expressly refer to the Invoice's unique reference number, the Billing Party shall allocate such payment to the oldest outstanding undisputed amount on any overdue Invoice of the same Billed Party in which case the relevant amount(s) on such Invoice will be deemed settled and the Billed Party shall no longer be entitled to raise any Billing Dispute in relation to such amount(s). For avoidance of doubt, such allocation cannot be made against an amount, which is already subject to a Billing Dispute, or the Billed Party raised a Billing Dispute about such Invoice within the Billing Dispute Notification Period. In such case the Billing Party will allocate such payment to the next oldest outstanding undisputed amount.
- 7.5 Notwithstanding the above, where the Billing Party fails to include any credit or deduction expressly confirmed by it in writing in the next Invoice, the Billed Party shall be entitled to off-set the same amount, which was expressly acknowledged by the Billing Party in writing, against such Invoice.
- 7.6 In addition to exercising any other rights the Billing Party may have under the Agreement or at law, where the amount of any Invoice in respect of which no Billing Dispute is raised within Billing Dispute Notification Period, is outstanding and remains unpaid for more than thirty (30) Calendar Days after the Due Date, the Billing Party reserves the right to take action, upon notice to the Invoiced Party, to recover any such amount as a debt due to the Billing Party.
- 7.7 In case the Billing Party issues a Credit Note to the Billed Party, but fails to deduct the amount of that Credit Note in the subsequent Invoice to the Billed Party, the Billed Party may use such Credit Note to off-set the amount payable under such subsequent Invoice subject to the total amount of such subsequent Invoice is higher or equal to the total amount of the Credit Note. Where the total amount of the Credit Note is higher than the total amount of the subsequent Invoice to the Billed Party, the Billed Party may not use the Credit Note to off-set any amounts payable by the Billed Party and the Parties will discuss in good faith to agree on a reasonable instalment plan for any such off-set.

8. Billing Errors and Overpayment

- 8.1 The Parties acknowledge that Invoices cannot be warranted as being free from errors. If the Billed Party discovers an error in an Invoice provided by the Billing Party, it must notify the Billing Party as soon as practicable. The Billing Party must make the adjustment necessary to correct that error in its next Invoice, if it is able to verify and correct the error.
- 8.2 If the Billing Party has omitted or miscalculated Charges from an Invoice, the Billing Party may include or amend (respectively) those Charges in a later Invoice, as long as the Billing Party is able to substantiate these Charges to the Billed Party and the inclusion or amendment is made within 90 (ninety) days of the issuing of the Invoice.
- 8.3 If the Billed Party makes an overpayment in error, it shall notify the Billing Party within ninety (90) Calendar Days after the date of the overpayment with sufficient details for the Billing Party to identify and verify the overpayment, including the invoice number, the amount that should have been paid and the reason for the overpayment.
- 8.4 The Billing Party shall, acting reasonably and in good faith, verify the overpayment within thirty (30) Working Days after receipt of notice of overpayment, and shall compensate the overpaid amount to the Billed Party within thirty (30) Working Days after the date of verification of the overpayment by (i) making a direct refund to the Billed Party or (ii) crediting the next Invoice issued to the Billed Party as per the choice of the Billed Party which choice must be documented in writing.

9. Billing Disputes

- 9.1 If the Billed Party, acting reasonably and in good faith, wishes to dispute in whole or in part an Invoice issued by the Billing Party, the Billed Party must (i) notify the Billing Party in writing, or (ii) submit a Billing Dispute via the Billing Party's system as instructed by the Billing Party in writing, as applicable (the "**Billing Dispute Notice**") within forty five (45) Calendar Days of receipt of that Invoice (the "**Billing Dispute Notification Period**"). Such notice must be sent to the Billing Representative of the Billing Party as nominated from time to time or submitted via the Billing Party system as instructed by the Billing Party in writing (including by email), whichever is applicable.
- 9.2 The Billed Party may only lodge a Billing Dispute with the Billing Party where the Billed Party, acting reasonably and in good faith, has reasonable grounds to believe that an error has arisen from, without limitation, one of the following circumstances:
- i. the Billing Party's billing system is, or has been, defective or inaccurate in respect of generating accurate and complete records of the Services that are the subject of the Billing Dispute;
 - ii. there is, or has been, a discrepancy between the Invoice in dispute and the records generated by the Billing Party's billing system;
 - iii. there is, or has been, a fraud perpetrated by the Billing Party; or
 - iv. the Billing Party has made another error in terms of records related to the Services or calculation of the Charges that are the subject of the Billing Dispute, or
 - v. there is any other error, miscalculation, or other deficiency in applying or calculating any Charges or amounts on the Invoice.
- 9.3 A Billing Dispute Notice shall specify:
- (a) details of the amounts in dispute;
 - (b) details required to identify the relevant Invoice and Charges in dispute including:
 - (i) the Invoice unique reference number;
 - (ii) the Invoice date;
 - (iii) the Invoice amount;
 - (c) the detailed billing verification information; the reasons for which the Billed Party disputes the Invoice, which must include a copy of any records that the Billed Party is relying on to support its claims of a Billing Dispute; and
 - (d) sufficient information for the Billing Party to be able to properly assess the disputed amounts in a timely manner.
- 9.4 The Billing Party shall confirm to the Billed Party receipt of the Billing Dispute in writing within five (5) Working Days following receipt of all the necessary information required for a Billing Dispute Notice as stipulated above.
- 9.5 The Billed Party may only invoke a Billing Dispute if it reasonably considers that a bona fide Billing Dispute exists and the total disputed amount exceeds BD50.

- 9.6 For the avoidance of doubt and unless the Parties agree otherwise, no Invoices may be disputed after the expiry of the Billing Dispute Notification Period. In case the Billed Party would attempt to raise a Billing Dispute including sending a Billing Dispute Notice to the Billing Party after the expiry of the Billing Dispute Notification Period, such action by the Billed Party shall be deemed void and the Billing Party is not obliged to respond to it.
- 9.7 Irrespective of any Billing Dispute, the Billed Party shall pay any undisputed amount in accordance with the normal payment procedures as set out in this Schedule 4 (Billing).
- 9.8 Where the Billed Party has paid any amount, including payment of any amount mentioned on an Invoice by the Due Date, and subsequently notifies the Billing Party of a Billing Dispute in relation to that same amount within the Billing Dispute Notification Period, the Billing Party is not obliged to refund any or all of that amount until the Billing Dispute is resolved in respect of that amount.
- 9.9 The Parties and in particular the Billing Representatives shall use all reasonable endeavours to resolve a Billing Dispute within thirty (30) Working Days after the date of receipt of the Billing Dispute Notice, or such other period that may be agreed by the Parties.
- 9.10 If the Parties are unable to resolve a Billing Dispute within thirty (30) Working Days after the date of receipt of the complete Billing Dispute Notice (or such other period that is agreed between the Parties), either Party shall be entitled to escalate the Billing Dispute by notifying the other Party's Billing Representative (the "**Billing Dispute Escalation Procedure**") for resolution by representatives of each Party that have full authority to settle the Billing Dispute (such representatives to be at a higher level of management than the Billing Representatives).
- 9.11 The designated Billing Dispute Escalation Procedure representatives must exercise all reasonable efforts including by meetings to discuss the Billing Dispute and negotiate in good faith in an effort to resolve that Billing Dispute. Each Party must meet all reasonable requests for relevant information received from the other Party during these negotiations to assist with the resolution of the Billing Dispute.
- 9.12 If a Billing Dispute is not resolved within twenty (20) Working Days of the date of escalation, either Party may, by written notice to the other Party refer the Billing Dispute to the Authority as per the applicable dispute resolution procedures with the explanation as to why the Dispute Resolution process under this Schedule 4 (Billing) failed to resolve the Billing Dispute.
- 9.13 If the Billing Dispute is resolved:
- (a) against the Billed Party, the Billed Party shall pay any outstanding amount to the Billing Party within ten (10) Working Days after the date of resolution of the Billing Dispute; or
 - (b) in favour of the Billed Party, the Billing Party shall within ten (10) Working Days after the date of resolution of the Billing Dispute:
 - (i) refund any disputed amount previously paid by the Billed Party to the Billing Party,
or
 - (ii) issue a Credit Note to be reflected in the subsequent Invoice to the Billed Party, corresponding to the outcome of the Billing Dispute in case the Billed Party did not pay the disputed amount pending the outcome of the Billing Dispute.

9.14 Although it is the best intention of the Parties to use the above process for resolving Billing Disputes to the fullest extent, nothing in this Schedule 4 (Billing) prevents either Party from pursuing any other remedy under this Agreement or at law that may be available to it if a Billing Dispute cannot be resolved to its satisfaction.

10. VAT

- 10.1 Unless expressly stated otherwise in this Agreement, any payments made by one Party to the other Party shall be inclusive of any tax, including the VAT.
- 10.2 If a Party wishes to charge the other Party VAT on a supply, it must first provide to the other Party its tax registration number and (if requested) a copy of its VAT registration certificate. If at any time one Party ceases to be registered for VAT, it must notify the other Party immediately.
- 10.3 Where VAT is payable by one Party under this Agreement, the consideration for the supply (VAT exclusive) shall be increased by an amount equal to the amount of VAT applicable at the prevailing rate at the time the supply is made (the "**VAT Amount**").
- 10.4 Where one Party makes a taxable supply or deemed supply of goods or services to the other Party, the other Party shall pay the VAT in addition to the payment or other consideration for that supply on the earlier of: (a) when the payment or other consideration is made; or (b) when the supply is made. The Party making the taxable supply or deemed supply of goods or services shall issue to the other Party a valid VAT invoice.
- 10.5 If this Agreement allows for termination where one Party fails to pay what is due to the other Party, this shall include the invoiced amount plus the VAT Amount that will be payable on that sum due in accordance with this Agreement.
- 10.6 Where the consideration for any taxable supply of goods or services is adjusted, the Parties will make all appropriate adjustments to the corresponding VAT, including the repayment of VAT, the further payment of VAT and the issue of any Credit Note or further VAT invoice valid for VAT purposes.
- 10.7 If the Parties are in dispute (with each other or with the relevant tax authority) or uncertain about the VAT obligations or implications of any supplies of goods or services pursuant to this Agreement, or the relevant tax authority determines that the Parties' treatment of VAT on such supplies is incorrect in any respect, the Parties shall use all reasonable endeavours to cooperate and reach agreement with each other and with the tax authority keeping each other fully informed and shall make all appropriate adjustments.
- 10.8 If one party (the "**Payer**") has paid VAT to the other party (the "**Payee**") but, as the direct result of the non-compliance by the Payee with the applicable VAT law (including, without limitation, by reason of any error or omission, failure to register for VAT, or a defective VAT invoice), VAT is not recoverable by the Payer who has paid in full as input tax (the "**Irrecoverable VAT**"), the Payee will indemnify the Payer as soon as reasonably practicable for the irrecoverable VAT, and any direct reasonable costs and expenses (the "**Direct Costs**", together with the irrevocable VAT, the "**Losses**"), unless the Losses result primarily from the negligence of the Payer or the grounds on which VAT cannot be recovered are disputed. The Payer shall keep the Direct Costs to a minimum and the Direct Costs shall be evidenced in writing. Immediately after the Payer becomes aware that VAT is not recoverable for the reason aforementioned, the Payer shall give notice in writing to the Payee of the matter, setting out the full details (including the grounds on which VAT cannot be recovered and the amount of the Irrevocable Costs and an estimate of the Direct Costs).

SCHEDULE 5 – FORECASTING

1 FORECASTING

- 1.1 By the start of every quarter commencing from the relevant Service Commencement Date,¹ and unless provided otherwise in relation to a particular Service in the relevant Service Description (Schedule 6) the Access Seeker shall supply to the Access Provider a forecast for each Service (i.e. intended New Connection Requests for each such Service separately) supplied to the Access Seeker covering each of the five (5) quarters following the date of the forecast.
- 1.2 The Access Seeker must submit forecasts to the contact nominated by the Access Provider.
- 1.3 On receipt of a forecast, the Access Provider shall review the forecast based on the following acceptance criteria:
- (a) Where relevant, compliance with the requirements of the relevant Service Description as set out in Schedule 6 (Service Descriptions);
 - (b) Completeness;
 - (c) Timely submission; and
 - (d) Adherence to the forecasting thresholds (as set out in paragraph 1.4 below).
- 1.4 In order to adhere to the forecasting thresholds, the actual percentage difference, for a given quarter, between the current forecast and the previous forecast must fall within the following thresholds for each quarter covered by the following forecast:

¹ As may be defined for certain Services in the relevant Service Schedule and where no such service specific definition applies, from the Actual RFS Date.

$$\text{Forecast percentage Q1} = (\text{Q2}_{\text{previous}} - \text{Q1}_{\text{current}}) / \text{Q2}_{\text{previous}}$$

SUBMIT	Q1	Q2	Q3	Q4	Q5	Q6
Submission Date Q1	Q1 Capacity Forecast (ORDER)	Q2 Capacity Forecast (+/- 10%)	Q3 Capacity Forecast (+/- 15%)	Q4 Capacity Forecast (+/- 25%)	Q5 Capacity Forecast (+/- 35%)	
Submission Date Q2		Q1 Capacity Forecast (ORDER)	Q2 Capacity Forecast (+/- 10%)	Q3 Capacity Forecast (+/- 15%)	Q4 Capacity Forecast (+/- 25%)	Q5 Capacity Forecast (+/- 35%)
Submission Date Q3			Q1 Capacity Forecast (ORDER)	Q2 Capacity Forecast (+/- 10%)	Q3 Capacity Forecast (+/- 15%)	Q4 Capacity Forecast (+/- 25%)
Submission Date Q4				Q1 Capacity Forecast (ORDER)	Q2 Capacity Forecast (+/- 10%)	Q3 Capacity Forecast (+/- 15%)
Submission Date Q5					Q1 Capacity Forecast (ORDER)	Q2 Capacity Forecast (+/- 10%)
Submission Date Q6						Q1 Capacity Forecast (ORDER)

Note that a reference to an 'Order' in this table should be understood as New Connection Request as defined in Schedule 8 – Dictionary.

- 1.5 Without prejudice to the above, the forecasts for the individual Service may involve additional requirement for providing more granular forecast based on geographical units or areas as may be specified for such Service in the relevant Service Description (Schedule 6).
- 1.6 If the forecast adheres to the acceptance criteria, then the Access Provider shall accept the forecast within five (5) Working Days. If the forecast does not adhere to the acceptance criteria, the Access Provider shall reject the forecast within five (5) Working Days clearly specifying the reasons for rejection.
- 1.7 If the Access Provider does not send a notification within five (5) Working Days then the forecast shall be deemed to be accepted.
- 1.8 Following rejection, the Access Seeker may resubmit a revised forecast within five (5) Working Days of the notification of rejection.
- 1.9 When the Access Seeker does not submit (or re-submit) a forecast, the Access Provider shall accept the most recently submitted forecast (if any) as the Access Seeker's signed off forecast. If there is no such available forecast, including where the Access Seeker fails to provide any forecast upon

request from the Access Provider, the Access Provider shall not be liable to guarantee any Service Level(s) for delivery of the Service(s) as stipulated in Schedule 7 (Service Levels) and/or provide any associated Service Level Penalties for such Service, and remains only obliged to deliver such Service(s) on a best effort basis.

- 1.10 The Access Seeker is obliged to prepare forecasts in good faith and use all reasonable endeavours to ensure that forecasts are accurate to make sure that the Access Provider does not engage internal and external resources unnecessarily or does not incur unnecessary costs or losses caused by inaccurate forecasts.
- 1.11 Where the Access Provider receives a forecast that it reasonably considers is unrealistic or unlikely to be accurate, the Access Provider may within seven (7) Calendar Days of the date of receipt of that forecast, provide a written notice to the Access Seeker setting out the reasons why the Access Provider considers the forecast is unreasonable or unrealistic, and requesting that the Access Seeker confirm that the forecast is accurate and complete ("Forecast Query").
- 1.12 The Access Seeker shall be obliged to review the Forecast Query in good faith and provide to the Access Provider, within seven (7) Calendar Days of receipt of the Forecast Query, either of the following:
- (a) a written notice confirming the accuracy of the submitted forecast, in which case the Access Seeker is deemed to have lodged the relevant forecast on the date of such confirmation, and all other dates in relation to that forecast and any ordering or provisioning occurring as a result will be adjusted accordingly; or
 - (b) a written notice attaching a revised forecast, in which case the Access Seeker is deemed to have lodged a forecast on the date of the confirmation of the revised forecast, and all other dates in relation to that forecast and any ordering or provisioning occurring as a result will be adjusted accordingly.
- 1.13 During the period that the forecasted volume is the actual New Connection Request(s) volume (Q1 in the diagram) then the actual number of the New Connection Requests processed can vary by +/- 20% of those forecasted during that quarter.
- 1.14 At the end of the period (Q1) any variance between forecasted New Connections and the actual New Connection Requests during that preceding quarter cannot be rolled over into the subsequent quarter (i.e., when Q2 becomes Q1).

The Service Level terms in Schedule 7 (Service Levels) shall apply to the actual number of all New Connection Requests up to the tolerance level of +20% of those forecasted for that quarter (as indicated in paragraph 1.13). For any New Connection Requests outside of the forecasted volume including the tolerance level of up to 20 %, the Access Provider is not obliged to adhere to any Service Level and shall deliver the respective New Connection Requests on a best effort basis only.

SCHEDULE 6.1 – SERVICE DESCRIPTION

WHOLESALE BITSTREAM SERVICE (WBS)

1. THE SERVICE

- 1.1 The Wholesale Bitstream Service (**WBS**) is a service which enables the Access Seeker to provide high speed products and services to its End Users via Connections over a digital pathway across the Access Provider's Network.
- 1.2 The digital pathway consists of one or more Connections, involving one or more Access Links between the ONT installed at the End User Premises and one or more Aggregation Links.
- 1.3 The WBS Service is available to Access Seekers holding an ISP Class License.

2. DEFINITIONS

Capitalised terms not defined in this Service Description are defined in Schedule 8 - (Dictionary) of the Reference Offer. Terms defined in this Service Description are specific to it.

Access Link means the digital point-to-point communications between an End User Premises and the OLT nearest to that End User Premises.

Aggregation Link means the logical or physical link between an Aggregation Point and an Access Seeker's Point of Presence (POP). An Access Seeker shall have the Access Provider establish at least one Aggregation Link before the implementation of a New Connection Request.

Aggregation Point means the point on the Access Provider's Network where the Aggregation Link is connected.

Access Provider Exchange means an exchange which has OLTs installed at the time of the Service Order.

Connection means the digital pathway that provides one end-to-end connection between one specific End User Premises and the Access Seeker's POP.

End User Premises Equipment means a modem and/or router, or other equivalent technology, necessary to support the End User's ability to use a retail service provided by the Access Seeker over the WBS Service. The End User Premises Equipment is supplied either by the Access Seeker or the End User, as the case may be.

GPON means a gigabit passive optical network, an access technology used by the Access Provider to provide a fibre based Connection at a fixed location.

IP means Internet protocol.

JUMBO frame means an Ethernet frame with a payload greater than the standard MTU of 1,500 bytes.

MTU means a Maximum Transmission Unit.

Network Boundary means, for a fibre based Access Link, the ONT at the End User Premises.

Non-Access Provider Equipment means any End User Premises Equipment which is not supplied, supported, and maintained by the Access Provider.

OLT means optical line terminal, network equipment in the Access Provider Exchange used in the provision of a WBS Connection.

ONT means optical network terminal, network equipment in the End User Premises used in the provision of a WBS Connection. The ONT is supplied, supported and maintained by the Access Provider and the Access Provider reserves the right to change or replace the ONT at any given time.

VLAN means the broadcast domain that is partitioned and isolated in the Access Provider's Network at the data link layer (OSI layer 2).

WBS Operations Manual means Annex 3 of this Schedule 6.1.

3. SERVICE TERMS

- 3.1 The WBS Service shall be made available to any End User on the basis of a Service Order of an Access Seeker. The process for submitting a Service Order to the Access Provider by the Access Seeker is set out in the WBS Operations Manual.
- 3.2 The WBS Service is provided in two separate categories: (i) the WBS Essential; and (ii) WBS Advanced.
- 3.3 The Access Seeker may not resell the WBS Service to another Licensed Operator.
- 3.4 The WBS Service shall enable each Access Seeker to connect a minimum of four (4) VLANs. The Access Seeker may request further VLANs subject to the charges set out in Schedule 3 - (Pricing) of the Reference Offer.
- 3.5 Where an Access Seeker deploys multicasts in the Access Seeker's core Network, the Access Seeker shall be able to use the WBS Service to pass multicast traffic over the Access Provider's Network transparently.
- 3.6 The WBS Service shall support MTU and JUMBO frames. Where required by an Access Seeker, the WBS Service shall support 1,700 byte frames.
- 3.7 If the Access Provider terminates the WBS Service in its entirety, then each WBS Access Link will terminate.
- 3.8 The Access Provider should ensure that all communications with the Access Seeker should be confidential and shall not be disclosed to other Licensed Operators.
- 3.9 The Access Seeker shall be the unique point of contact and shall be solely responsible to its End User for all issues, including but not limited to issues related to the installation of the Access Provider ONT and any ancillary works required for such installation, including but not limited to cabling and civil works, and any relevant Access Seeker equipment on the End User Premises.

4. NETWORK AVAILABILITY

- 4.1 The Access Seeker acknowledges that where GPON fibre is available, the Access Provider will only supply a fibre-based WBS Service in accordance to the process set out in the WBS Operations Manual.
- 4.2 GPON fibre will be considered available where a fibre access cable has been dropped to the fibre distribution point nearest to the End User Premises and that End User Premises can be connected to the Network upon request within the timeframes provided for in Schedule 7 – (Service Levels) of the Reference Offer.
- 4.3 For the purposes of clause 4.2 above, an End User Premises that can be connected to the Network within the timeframes provided for in Schedule 7 – (Service Levels) of the Reference Offer means that the End User Premises is ready to receive the WBS Access Link and that the ONT can be installed at the point chosen by the End User without the requirement of any installation and/or civil works including, but not limited to, additional lead- in piping, conduits, etc.

Provision of the Service

- 4.4 For each Service Order the Access Seeker shall inform the End User that the installation and operation of the WBS Service may require changes to the placement of existing telecommunications devices or changes of equipment.
- 4.5 Data transport using the WBS Service between an OLT and an Access Provider Aggregation Point, or MSAN equipment and an Access Provider Aggregation Point, are available for the range of WBS products identified in Annex 1.
- 4.6 Maximum attainable WBS speed shall be subject to the physical distribution of the bandwidth set out at Annex 1.
- 4.7 The Access Provider shall provide access to an online tool that identifies up-to-date accurate digital coverage maps for the areas in the Kingdom of Bahrain covered by the WBS Service (i.e., block or building) and the Connection type (i.e., copper or fibre) to ensure that the right service is offered by the Access Seeker to the End User. This online tool should be updated at least on a monthly basis.
- 4.8 The Access Provider is responsible to ensure that its Network has the required number of ports and Network elements to fulfill the Access Seekers' requests in accordance with the Service Level Terms in Schedule 7 – (Service Levels) of the Reference Offer.
- 4.9 On the completion of a Service Order, the Access Provider will ensure that the WBS Service is tested in accordance with ITU Y.1564 standard.
- 4.10 The Access Seeker shall in respect of this WBS Service comply in all respects with its obligations under Article 78 of the Law and any regulation or decision issued by the Authority in relation to lawful access.

5. MAINTENANCE AND COMPLIANCE

- 5.1 The Access Provider shall provide Network maintenance and support services in accordance with the processes set out in the WBS Operations Manual.
- 5.2 The provision of a WBS Service or the implementation or transfer of the WBS Service includes the provision of cabling of up to twenty (20) metres for the installation of the ONT. Any distance in excess of 20 metres shall be subject to commercial charges applicable at the time of such request. For the avoidance of doubt, the installation of the fibre does not include any internal works and/or civil works to accommodate such fibre. The Access Provider shall clearly define the demarcation point of its access Network and therefore of the WBS Service.
- 5.3 The Access Seeker shall ensure that Non-Access Provider Equipment supplied by the Access Seeker for the purposes of a WBS Connection:
- (a) meets the specifications and requirements defined by relevant international telecommunications and engineering standards; and
 - (b) is equipment approved under Article 38 of the Law.
- 5.4 The Access Provider shall connect the WBS Service by the relevant RFS Date. The Access Provider shall notify the Access Seeker when the Connection has been completed in accordance with the Service Order procedures set out in the WBS Operations Manual.

6. CHARGES AND BILLING PERIOD

- 6.1 The Access Seeker shall pay to the Access Provider the relevant Charges set out in Schedule 3 - (Pricing) of the Reference Offer.
- 6.2 All Charges and sums due from one party to the other under this Agreement are exclusive of VAT. Any VAT shall be charged in accordance with the relevant regulation in force at the time of making the taxable supply and shall be paid by the paying party following receipt from the billing party of a valid VAT invoice.

7. AGGREGATION LINK(S)

- 7.1 Following a request from the Access Seeker, the Access Provider shall provide Aggregation Link(s) as described in Annex 1 (Aggregation Links for WBS services) to this Schedule and at the Charges set out in Schedule 3 - (Pricing) of the Reference Offer.
- 7.2 The first single aggregation link of 10 Gbit/s, the charge for which is already included in the MRC, can be provided for a maximum of one (1) Access Seeker's Points of Presence. In the event that the Access Seeker requests additional aggregation bandwidth, the Access Seeker will be required to procure additional aggregation capacity as set out in Annex 1 (Aggregation links for WBS services) to this Schedule and as priced in Schedule 3 – (Pricing) of the Reference Offer.

ANNEX 1 - WBS PRODUCT LIST

WBS Services (fibre) are defined for both (i) WBS Essential and (ii) WBS Advanced as shown in the tables below:

WBS Essential		WBS Advanced	
Download Speed	Upload Speed	Download Speed	Upload Speed
Voice only 1.024 Mbit/s	Voice only 512 Kbit/s	Voice only 2.024 Mbit/s	Voice only 512 Kbit/s
300 Mbit/s	60 Mbit/s	300 Mbit/s	150 Mbit/s
500 Mbit/s	250 Mbit/s	500 Mbit/s	350 Mbit/s
750 Mbit/s	375 Mbit/s	750 Mbit/s	525 Mbit/s
1 Gbit/s	500 Mbit/s	1 Gbit/s	1 Gbit/s
2 Gbit/s	1 Gbit/s	2 Gbit/s	2 Gbit/s

Aggregations links for WBS services

First single Aggregation Link 10Gbit/s*
Any additional Aggregation Link 10Gbit/s (on request)
Aggregation Link 100Gbit/s (on request)

COPPER-BASED WBS SERVICES

Residential (as per the previous Reference Offer)		Non-Residential (as per the previous Reference Offer)	
Download Speed	upload	Download Speed	Upload
Up to 20Mbit/s	2.048Mbit/s	Up to 20Mbit/s	2.048Mbit/s

ANNEX 2 - WBS SERVICE – TECHNICAL DIAGRAM

GPON Based Network Topology:

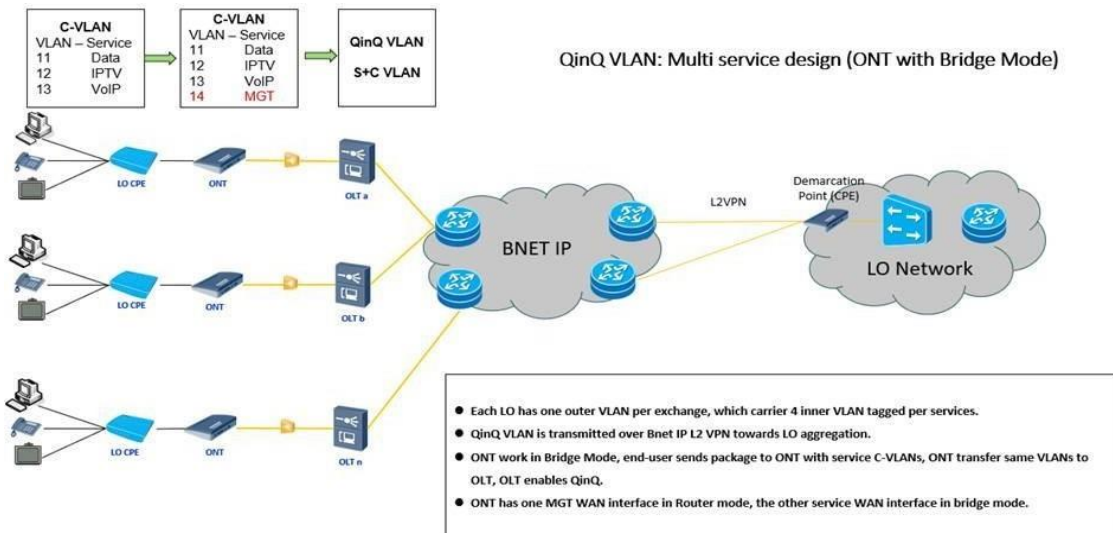
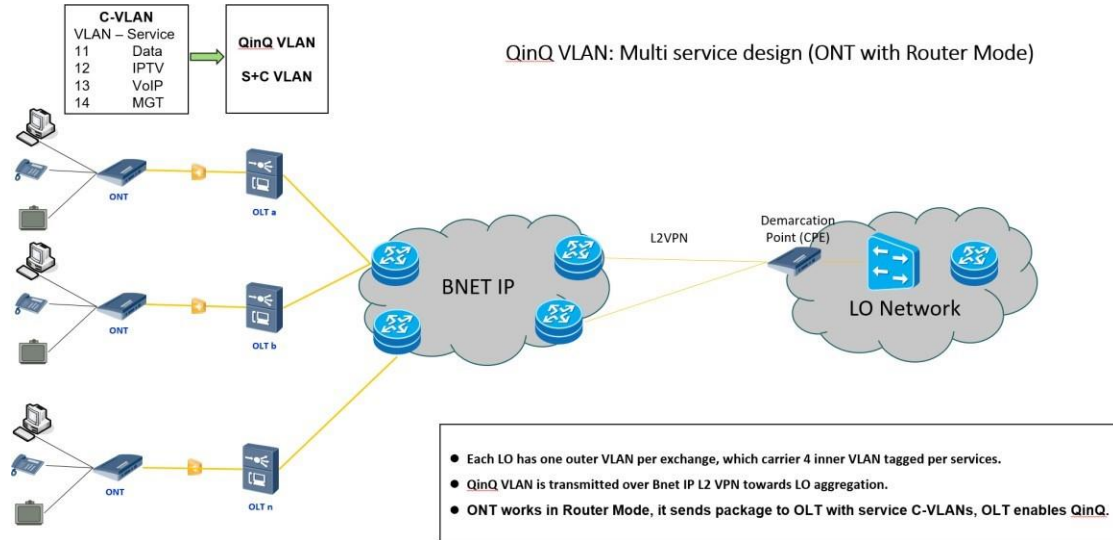

ANNEX 3 TO SCHEDULE 6.1

WHOLESALE BITSTREAM (WBS) SERVICE OPERATIONS MANUAL

This document describes the onboarding, provisioning, fulfilment and fault handling process for the Wholesale Bitstream Service between the Access Provider and the Access Seeker. This document forms an integral part of the Access Provider's Reference Offer and of Schedule 6.1.

1. Onboarding

1.1 Onboarding Requirements

1.1.1 Access Seeker Onboarding

- (a) The Access Seeker shall review, acknowledge, and sign for Access Provider's counter signature the Supply Terms (Schedule 9) of the Reference Offer.
- (b) The Access Seeker shall have in force and maintain for the term of the Agreement a broad form of public liability insurance to the value of at least BD 250k and property insurance for the assets used in relation to this Agreement to the value of at least BD 100k.
- (c) These policies shall be with a licensed insurance company in the Kingdom of Bahrain and on terms and for coverage limited by only standard industry exclusions or exceptions.

1.1.2 Credit Security

- (a) The Access Seeker shall have in force and maintain security as requested by the Access Provider as required under the Reference Offer Supply Terms.

1.1.3 Licensing and Authorizations

- (a) The Access Seeker shall comply with the terms and conditions set out in the Reference Offer and relevant Service Descriptions, including obtaining any prior authorizations and shall maintain the required licenses as provided for by the Regulator.

1.1.4 Confidentiality and Non-Disclosure

- (a) The Access Seeker is required to execute the Access Provider's Non-Disclosure and Confidentiality Agreement and comply with any information protection.

1.1.5 BNET BSS

- (a) The Access Provider allows the Access Seeker to integrate via API to the Access Provider's BSS, which is designed based on the telecom standard framework for business process, the enhanced Telecom Operations Map ("eTOM"). for placement of Service Order(s) and Service Request(s).
- (b) The Access Provider also provides an interface portal (the Access Provider Portal) for Access Seeker who do not have the capability to integrate via API. The Access Provider Portal is a standard Portal that may not provide the same enhancements and benefits that an Access Seeker would receive through API integration.
- (c) The Access Provider recommends access via API integration to its BSS.

1.1.6 Process for API Integration

- (a) If the Access Seeker opts for API integration, it shall contact the Access Provider Relationship Manager for API documentation.
- (b) Access Seeker will be required to undergo a trial phase for testing the API integration and will be required to sign off on the successful completion of the testing phase. Without limitation, the Access Seeker and Access Provider will confirm the following where applicable:
 - (i) The system integration has been completed;
 - (ii) The Access Seeker has portal access and credentials;
 - (iii) Network aggregation is implemented and tested;
 - (iv) A billing test on the relevant Service is confirmed; and
 - (v) Service provisioning of for the relevant Service is confirmed.
- (c) The Access Provider should ensure that all communications with the Access Seeker should be confidential and shall not be disclosed to other Licensed Operators.

2 Fulfillment

2.1 Request to Answer

- 2.1.1 The Request to Answer process is a pre-order management process. This process comprises of activities relevant to managing Access Seeker information requests across all communication channels (Access Seeker interfaces).
- 2.1.2 Specific information requests or product requests from the Access Seeker are qualified and addressed.
- 2.1.3 Pre-order Management consists of a set of functions across the API interface that enables the interaction before the Access Seeker order can be created.

2.2 WBS Address & Service Availability Check

- 2.2.1 Prior to the Access Seeker placing a Service Order for the relevant Service, it is necessary to check whether the service infrastructure is available. The Access Seeker is provided with a tool to conduct varying levels of pre-qualification checks before submitting a Service Order.
- 2.2.2 In the circumstances where the Access Seeker chooses to submit a Service Order following the pre-qualification checks, the Access Provider shall verify the Service Order through two levels of Service availability check:
 - (a) **Address Availability Check** – to identify whether the End-User address exists in the Access Provider Address database which is updated by the IGA (Information & eGovernment Authority) through their address database; *and*
 - (b) **Service Availability Check** – to identify whether Access Provider's infrastructure currently exists at the End-User's Address and can be served through the relevant Service.

2.2.3 These qualification steps identify whether the Fulfilment request raised by the Access Seeker can be accepted. Both checks can be performed using the portal and the API integration and are performed by the Access Seeker. A response from the service availability check that an address qualifies for Service Connection to the Access Provider Network should not be relied upon as a commitment that Access Seeker will be able to connect to that address. Information returned by the Access Provider BSS for service availability is current at the time the information request is made. Footprint, serviceability and serviceability date are all subject to change.

2.2.4 The details of using the portal & API integration to interact with business processes mentioned in this Operational Manual are detailed in the LO API documentation shared by Access Provider.

2.3 WBS Service Request

- 2.3.1 In the event neither the address nor the service availability check is successful, the Access Seeker may:
- (a) Where the address is not available on the Access Provider's database, raise a Service Request to add the address to the Access Provider's address database; and
 - (b) Where the service availability is unsuccessful, request cost and time estimation for the delivery of the Service.

2.4 Service Requests

- 2.4.1 If the Access Seeker opts for any of the options set out in clause 7 above, this shall be considered as a Service Request.
- 2.4.2 The Access Provider will, on a monthly basis, update the address list in the Access Provider Database which the Access Seeker shall be privy to if integrated through API or through access of the Portal. This information is provided by the IGA.
- 2.4.3 The Access Seeker is required to provide the information requested as per the form and mandatory fields set in the Portal/API in order to submit a Service Order. It is important for the Access Seeker to adhere to these mandatory fields, or otherwise may run the risk of having its Service Request rejected.
- 2.4.4 If Access Seeker finds that the address does not exist through the address availability check while raising the Service Order, the Access Seeker shall be eligible to raise a Service Request through the Portal or API for an address addition.
- 2.4.5 Every submitted Service Request will be allocated a unique identifier for tracking and managing the Request.
- 2.4.6 As part of the Service Request, the Access Seeker shall input the required information as per the below list, or in accordance with the required fields set out in the Portal/API:
- (a) Flat number– To be provided for address having flat number.
 - (b) Building number

- (c) Street name
- (d) Road Number
- (e) Block Number
- (f) City
- (g) Area
- (h) Country

- 2.4.7 The Access Seeker shall provide a valid End-User CR/CPR or any official authority reference identification.
- 2.4.8 The Access Seeker is required to attach mandatory End-User proof of address documents when raising a Service Request for address addition, such as a valid address card or any documentation which may be deemed as necessary by the IGA authority to validate the End- User address.
- 2.4.9 The Access Seeker shall be responsible to ensure the validity, authenticity, and completeness of the above-mentioned attachments.
- 2.4.10 Where any of the documentation is considered as invalid, the Service Request shall be reassigned to the Access Seeker for rectification.
- 2.4.11 Where the address is validated by the IGA and accepted, such address will be updated in BNET database and the Service Request shall be closed. Whilst the address may be updated, this does not guarantee that the Service is covered. In this case, the Access Seeker may raise a Service Request for a cost assessment (please see refer to the process below on a cost assessment Service Request).
- 2.4.12 For the avoidance of doubt, if any of the above information requested as inputs from the Access Seeker have not been provided, the Service Levels in Schedule 7 of the Reference Offer will not be applicable.
- 2.4.13 Where the Access Seeker opts for Service provision through a Service Request and the geographical area is not covered by the Access Provider's network roll-out roadmap, the Parties may, subject to a feasibility study conducted by the Access Provider as per the Access Seeker's request, agree on an ad-hoc deployment of GPON fibre to this particular location charged on a time and materials basis.
- 2.4.14 The Access Seeker shall send a cost assessment Service Request providing the Service/product details, as well as the requesting address.
- 2.4.15 The Access Seeker must verify that a valid address and Service/product details (Service ID, Service feature requirements, i.e. committed bandwidth) have been provided as part of the Request in accordance with the Portal/API integration requisite fields.
- 2.4.16 Where the address is not considered as part of a "ready area" or where the Access Seeker wishes to fast track the Service deployment plan where applicable, the Access Seeker must approve the cost provided by the Access Provider as part of its cost assessment. This cost shall be billed to the Access Seeker once

approved, and the Access Provider shall commence deploying the Service to the requisite address detailed in the Service Request. This will denote the raise of a Service Order linked to the approved cost assessment Service Request.

2.4.17 For the avoidance of doubt, the Access Seeker's Service Request shall be rejected if:

- (a) it does not specify a valid address, or the address cannot be verified by the IGA; or
- (b) it does not provide the required inputs delineated above; or
- (c) it does not have the authorizations provided for by its License to avail of the Service.

2.4.18 No service commitment or network resources reservation should be assumed to be done as a result of an unapproved cost assessment Service Request.

2.5 Order to Payment – Fulfilment of Service Orders

2.5.1 The Access Seeker may submit a New Connection ("New Provide") Service Order through API integration or via the Access Provider Portal.

2.5.2 The Access Provider will process these Service Orders as described below:

2.5.3 Service Orders will only be processed during the Access Provider's Working Hours.

2.5.4 The Access Provider will acknowledge receipt of the Service Order within fifteen (15) minutes of receipt of the Service Order

2.5.5 For Service Orders submitted outside of Working Hours, the Access Provider shall acknowledge the Service Request within fifteen (15) minutes following the start of the first Working Hour after receipt of the Service Order.

2.5.6 A Service Order shall be considered invalid if:

- (a) it is incomplete or incorrect or illegible or cannot reasonably be understood;
- (b) it does not properly identify the End User Premises;
- (c) a valid written End User Consent cannot be produced by the Access Seeker to support the Service Order; and/or
- (d) it resulted from a processing error.

2.5.7 At the time of rejection, the Access Provider shall provide sufficiently detailed written reasons for rejection to the Access Seeker.

2.5.8 The SLAs in schedule 7 shall only be applicable to forecasted Service Orders in line with Schedule 5 (Forecasting) of the Reference Offer.

2.5.9 A Service Order must be in the format notified by the Access Provider from time to time and be submitted through an online digital interface notified to the Access Seeker by the Access Provider, from time to time.

- 2.5.10 The Access Seeker shall, upon a reasonable and justified request, provide the Access Provider with a copy of the End- User Consent and CR for Non-Residential End Users. The Access Provider shall treat the copy of the End-User Consent as confidential and shall not disclose a copy of the End-User Consent to other Licensed Operators under any circumstances.
- 2.5.11 Only in the case where the online digital Portal or the API integration setup mechanisms are not accessible, electronic mails shall be accepted as a communication mechanism.
- 2.5.12 The Access Seeker's Billing Account must be active and not in a suspended state in order for the Access Provider to accept and proceed with the Service Order.
- 2.5.13 Save for the exceptions set out in the Reference Offer and this Operations Manual, the Access Provider shall provision the WBS Service Order within the SLAs specified in Schedule 7 of the Reference Offer. The Access Provider reserves its rights to suspend or reject the Service Order post Access Provider acceptance and acknowledgement of the Order, if the following issues arise during Service delivery:
- (a) Issues related to End-User and/or Access Seeker as defined in Schedule 7; and
 - (b) Issues related to duct and infrastructure readiness as defined in Schedule 7.
- 2.5.14 For the scenarios set out in paragraph 2.5.13 and 2.5.13 (b) above, the Service Levels set out in Schedule 7 shall be suspended until such issues are resolved and the Access Provider is able to proceed with the processing of the Service Order.
- 2.5.15 End-User permissions & site readiness is the responsibility of Access Seeker to communicate to the Access Provider.
- 2.5.16 The Access Seeker shall have to book an initial appointment at the time of raising the Service Order.
- 2.5.17 In the case where the End-User will not be able to attend the initial booked appointment, the Access Seeker and End- User may opt to re-book their appointment. This must be done within two (2) days from the day of the missed appointment.
- the SLA shall be suspended and shall restart on the day the second appointment is booked.
- 2.5.18 The time slots with regard to appointment rebooking will be made available to the Access Seeker two days from the date of initiating the re-booking of appointment.
- 2.5.19 If a Service Order cannot be fulfilled within 10 Working Days from the submission of the Service Order due to infrastructure related issues, the Target Completion Date will be provided as detailed in Schedule 7 of the Reference Offer, and the SLAs on the Access Provider will be suspended.

2.6 Request to Change

- 2.6.1 In the event the Access Seeker elects to reschedule or cancel a Service Order past the point-of-no-return, the Access Seeker shall be charged rescheduling or cancellation charges in line with Schedule 3 (Pricing) if the rescheduling/cancellation request is made twenty-four (24) hours from the appointment date

provided to the Access Seeker by the Access Provider. In such cases, the Service Levels set out in Schedule 7 shall be suspended until the appointment is booked.

- 2.6.2 The point of no-return shall be defined as the instance when the appointment date has been provided to the Access Seeker by the Access Provider, and prior to any visits made by the Access Provider to the End User Premises.
- 2.6.3 To initiate a change to an existing WBS Service used by the Access Seeker to supply a service to an End User, the Access Seeker shall provide the Access Provider with a properly completed WBS Change Request, in the format notified by the Access Provider from time to time, submitted by electronic mail (or other electronic format, which may include an online digital interface) to the address notified to the Access Seeker by the Access Provider, from time to time.
- 2.6.4 Access Provider shall respond to the WBS Change Request in accordance with the process detailed for Service Orders at 2.5.9 where applicable.
- 2.6.5 The SLAs for different WBS Change Requests are specified in Schedule 7 of the Reference Offer.
- 2.6.6 In addition to the rejection reasons set out at paragraph 2.5.6 the Access Provider may also reject a WBS Change Request if it is not submitted in accordance with paragraph 2.6.3
- 2.6.7 The Access Provider may, in its sole discretion, elect to accept any WBS Change Request notwithstanding that there is any defect in that WBS Change Request, if the Access Provider considers that such defect does not have a material effect on the Access Provider's ability to process the WBS Change Request and provide the WBS Service. A WBS Change Request may comprise of any of the following:
 - (a) External Relocation
 - (b) Internal Relocation
 - (c) Upgrade
 - (d) Downgrade
- 2.6.8 If under the above circumstances, the intended new address does not have fiber, a Target Completion Date will be provided within 10 Working Days from raising the WBS Change Request.
- 2.6.9 External relocation orders will be performed based on a "new provide" to the new address and a cessation on the old address.

2.7 Exceptions

- 2.7.1 The Access Provider shall, subject to the exceptions, limitations and conditions specified in this Service Description and/or Supply Terms, provision and deliver the WBS Service on or before the RFS Date and in accordance with Schedule 7 - (Service Levels) of the Reference Offer.
- 2.7.2 The Parties acknowledge and accept that exceptional circumstances, such as those set out below, may give rise to delays in any stage of the provisioning and delivery of a Service Order. If the occurrence of

any of the events below takes place, the Access Provider shall communicate the Exceptional Delivery Date to the Access Seeker and shall not be held liable for the Service Level Penalties. The exceptional circumstances shall only comprise of:

- (a) a Force Majeure Event or a Regulatory Event; or
- (b) Emergency Maintenance; or
- (c) any material breach of the Access Seeker's obligations.
- (d) The Access Provider shall, in notifying the Access Seeker of the Revised Delivery Date, provide sufficient evidence to justify the reasons for the delay of the delivery.

2.7.3 The Access Provider shall not be obliged to further process a Service Order where:

- (a) the relevant WBS Service cannot meet Service Qualification; or
- (b) following the provision of reasonable notice by the Access Provider, an authorized person from the End User or the Access Seeker is not available to provide further information when requested.

2.8 Notification of Completion of Order

2.8.1 The Access Provider shall, on the same Working Day of completion of a Service Order, notify the Access Seeker of completion.

2.8.2 In the case of a Service Order, the Access Provider is entitled to rely on an evidence that the relevant End User:

- (a) has given a valid End User Consent in relation to the requested Service Order; and
- (b) in the case of a Change Request understands and has requested the Change.

3 Fault Handling and Resolution

3.1 Faults

3.1.1 The Access Provider's responsibility for faults in the Wholesale Bitstream Service is limited to the following:

- (a) Any fault that affects the Wholesale Bitstream Service and/or in the Access Provider's Network, Systems, Access Provider Equipment where such fault is not caused, whether directly or indirectly, by the Access Seeker's actions or omissions;
- (b) Any fault that the Wholesale Bitstream Service and/or in the Access Provider's Network, Systems, Access Provider Equipment where such fault is directly caused by the Access Provider's action or omission.

- 3.1.2 The Access Seeker is responsible for any fault that affects the Wholesale Bitstream Service and/or in the Access Provider's Network, Systems, Access Provider Equipment where such fault is caused, whether directly or indirectly, by the Access Seeker's actions or omissions, whether through negligence or otherwise.
- 3.1.3 The Access Seeker shall be responsible for providing an initial fault diagnosis and reporting for any fault reported to the Access Seeker by its End-Users. The Access Seeker must ensure that its fault reporting service is competent and sufficiently resourced as per the quality standards set in the industry.
- 3.1.4 Pursuant to paragraph 0 above and prior to notifying the Access Provider of a fault, the Access Seeker must:
- (a) Confirm the presence of a fault;
 - (b) Perform an initial fault diagnosis to identify where the fault has arisen;
 - (c) Use all reasonable endeavors to investigate the fault and find out all relevant information from its End-User;
 - (d) Confirm that the fault falls under the Access Provider's responsibility with a clear explanation as to why it considers this to be the case.
- 3.1.5 When the Access Seeker has met the conditions set out in paragraph 0 above, it must report any fault that the Access Provider falls under the Access Provider's responsibility, as set out in paragraph 3.1.1 above, to the Access Provider and provide reasonable information regarding the fault by raised a Customer Problem ticket.
- 3.1.6 If the fault is found to be outside of the Access Provider's responsibility, as set out in paragraph 3.1.1 above, or where the Access Provider cannot confirm the presence of a fault, the Access Provider may charges the Access Seeker on a time and materials basis.
- 3.1.7 The Access Provider will not accept any report of a fault from End User of the Access Seeker. Any End User of the Access Seeker mistakenly contacting the Access Provider will be advised to contact the Access Seeker. The Access Seeker must ensure that all its End Users are informed that all faults must be reported to the Access Seeker.

3.2 Fault Resolution

- 3.2.1 The Access Seeker will facilitate contact with any relevant End User of the Access Seeker and/or arrange a site visit this is reasonably required by the Access Provider to clarify the nature of, or undertake work to fix, any Reported Fault. the Access Provider may communicate End User of the Access Seeker directly so long as such communications are confined to technical matters directly concerning the Reported Fault.
- 3.2.2 Upon the Access Provider' acknowledgement of a Reported Fault that is the Access Provider' responsibility, the Access Provider will:
- (a) diagnose and fix the Reported Fault;

- (b) following the initial diagnosis, provide an indication to the Access Seeker of the likely time to fix the Reported Fault (Response, provided that the Access Provider has no obligation to provide such indication if the Reported Fault is fixed at the time of initial diagnosis).

3.3 Reporting Faults to the Access Provider

3.3.1 The Access Provider has two automated channels which allows the Access Seeker to create customer trouble tickets:

- (a) Portal
- (b) API Integration

3.3.2 The two channels allow Access Seekers to:

- (a) create a new trouble ticket;
- (b) retrieve status and updates on a trouble ticket; and
- (c) Receive ticket resolution and closure updated along with root cause.

3.3.3 Faults can be logged 24 hours a day, seven days a week.

3.3.4 The Access Seeker must use the Access Provider Portal or API Integration for reporting all faults regarding the WBS Service. If the Access Seeker uses any other method to report a fault, the fault will not be acknowledged by the Access Provider or attended and the Service Levels as defined will not apply to that fault.

3.3.5 Where the Access Provider advises the Access Seeker that Portal /API is unavailable, the Access Seeker must submit fault reports to the Access Provider by calling the Access Provider Call Center. The Access Provider will use all reasonable endeavors to advise Access Seekers immediately upon becoming aware that the Portal /API is unavailable.

3.3.6 Once the Access Seeker has provided initial fault diagnosis, determined that it requires the Access Provider assistance to resolve the fault, the following information is required when reporting a fault:

- (a) confirmation that the initial fault diagnosis has been completed;
- (b) contact name and phone number of the Access Seeker staff member logging the fault;
- (c) contact name, phone number, and alternate phone number of the End User experiencing the fault (where appropriate);
- (d) End User's Service Identifier for service that is experiencing the fault (where appropriate);
- (e) fault type and description;
- (f) time the fault occurred;
- (g) address and contact details for the site of the fault (where appropriate); and
- (h) any other relevant information.

3.3.7 If any of the above information set out from (a) to (h) in paragraph 3.3.6 above is not provided, the Service Levels in the Schedule 7 of the Access Provider Reference Offer will not apply.

3.4 Fault Report Acknowledgement

3.4.1 When a fault report is received, the Access Provider will advise the Access Seeker, acknowledging receipt of the fault report within specified SLA in schedule 7.

3.5 Fault Tracking

3.5.1 All faults will be logged in Portal /API integration and the Access Seeker will be given a fault reference number where the access seeker can get the update on the raised trouble tickets and the progress to restore the service.

3.5.2 Where the Access Provider subsequently becomes apparent that the fault restoration time cannot be met, the Access Provider will advise the Access Seeker of a revised fault restoration time.

3.6 End-User Premises Visit

3.6.1 If the Access Provider identifies the need to send a field engineer to the end-user, the Access Provider will update Access Seeker trouble ticket in portal/API integration.

3.6.2 The Access Seeker's is responsible for coordinating site access, visit appointment and any required outage window with the End User.

3.6.3 In case end-user does not respond to the Access Provider calls to confirm appointment, the KPI will be stopped and access seeker will need to re-book appointment and inform the Access Provider with new appointment booked.

3.7 Fault Types

3.7.1 If the issue can be fixed remotely, the Access Provider will fix the issue and the customer trouble tickets will be updated accordingly.

3.7.2 In the event where the issue is within passive or active resources, a planned outage will be required and the Access Provider will inform the access seeker on planning outage timings.

3.7.3 access seeker representative to be available at the time of the end-user visit to verify and accept the resolution of the end-user fault.

3.8 Fault Closure

3.8.1 Once the fault has been resolved, the Access Provider will notify the Access Seeker via Portal/API integration that the fault has been resolved, confirm the reference number and, where possible, provide the cause of the fault and any actions taken to reach resolution.

3.9 Emergency and Core Network Faults

3.9.1 Emergency and Core Network faults reported to the Access Provider will be treated on a case-by-case basis. In the first instance, the Access Provider will propose a temporary solution. However, in the absence of a viable temporary solution, the Access Provider may schedule a callout to respond to Core Network faults, or to emergency faults relating to mass outage that impacts an entire block or area.

4 Complaints

4.1 This section deals with Access Seeker enquiries where the Access Seeker is not satisfied with a product and/or handling and timeliness of an enquiry.

4.1.1 Access Seekers can reach their designated account manager to report any complaint related to non-technical issues.

4.1.2 Access Seeker can raise their complaints through the portal and/or API integration

4.1.3 The Relationship Manager will acknowledge the receipt of the complaint within 2 working days.

4.1.4 A response to the complaint will be provided to the Access Seeker within 5 working days.

4.1.5 In case the Access Seeker finds the provided solution is not satisfactory, the complaint can be escalated to Head of relationship manager.

4.2 The Access Provider Network, the Access Provider Owned Equipment and Property.

4.2.1 For the Access Seeker's own safety, and so that services supplied by the Access Provider are not disrupted, the Access Seeker must help safeguard the Access Provider' Network and the Access Provider Owned Equipment. The Access Seeker must:

- (a) Follow the Access Provider' reasonable directions when connecting anything to the Access Provider' Network or any the Access Provider Owned Equipment
- (b) Only allow people authorised by the Access Provider to work on or around the Access Provider' Network or the Access Provider Owned Equipment; and
- (c) make sure everyone the Access Seeker is responsible for also meets these obligations.

4.3 Access Seeker Responsibility towards the Access Provider Owned Equipment

4.3.1 At the time any the Access Provider Owned Equipment is supplied, the Access Provider will use all reasonable endeavours to make sure it is safe, durable and approved for connection to the rest of the Access Provider' Network.

4.3.2 Where the Access Provider supplies the Access Seeker with any the Access Provider Owned Equipment, the Access Seeker will, where applicable:

- (a) leave the Access Provider Owned Equipment installed and not use it otherwise than in specified in the service description.
- (b) protect the Access Provider Owned Equipment from radio or electrical interference, power fluctuations, abnormal environmental conditions, theft and any other risks of loss or damage.
- (c) if the Access Provider Owned Equipment is lost, stolen or damaged, notify the Access Provider directly and pay for repairing or replacing it, except where the loss, theft or damage was caused by the Access Provider;
- (d) follow the Access Provider' reasonable directions when using the Access Provider Owned Equipment and never use the Access Provider Owned Equipment for purposes for which it is not designed; and
- (e) not encumber the Access Provider' title to the Access Provider Owned Equipment or expose such title to third Party claims and notify the Access Provider if it becomes aware of any third-Party claim.

4.3.3 When any the Access Provider Owned Equipment is no longer required the Access Seeker:

- (a) must return the Access Provider Owned Equipment to the Access Provider;
- (b) will take reasonable care to avoid causing damage when returning the Access Provider Owned Equipment to the Access Provider and be responsible for any damage to the Access Provider Owned Equipment; and
- (c) must pay all Charges for the Access Provider Owned Equipment until such time as it is returned to the Access Provider.

5 Planned Outages and Maintenance

5.1 General Obligations

- 5.1.1 The Access Provider may suspend any WBS in order to carry out Planned or Emergency Maintenance.
- 5.1.2 In the case of Planned Maintenance, the Access Provider shall use its best endeavors to carry such activity during the night or at weekends or other quiet periods.
- 5.1.3 The Access Provider shall give ten (10) Working Days' notice of each Planned Maintenance activity affecting a particular WBS Service or group of WBS Services. This shall include the circuits affected, the date and time of the suspension and the likely duration of the suspension.

- 5.1.4 The Access Provider shall give three (3) Days' notice of each Emergency Maintenance activity affecting a particular WBS Service or group of WBS Services. This shall include the circuits affected, the date and time of the suspension and the likely duration of the suspension.
- 5.1.5 In cases of Emergency Maintenance, the Access Provider shall advise the Access Seeker within five (5) hours after service is restored with a report of the cause of the Fault.
- 5.1.6 The Access Provider shall use its reasonable endeavors to take into account the reasonable operational concerns of the Access Seeker before implementing any Planned Maintenance and be carried in accordance with Schedule 7 of the Access Provider's Reference Offer.

5.2 Types of maintenance and support services

- 5.2.1 The Access Provider shall provide Network maintenance and support services such as ONT replacement and fibre patch cord replacement, in accordance with the Service Levels set out in Schedule 7 - (Service Levels) of the Reference Offer. In the event that any service components will require replacement due to Access Seeker or End User misuse, the Access Provider reserves the right to re-charge the replacement cost of these equipment(s) to the Access Seeker.
- 5.2.2 The Access Provider shall ensure that all of the Network elements used to provide the WBS Service are provided to the Access Seeker at the same level of quality of service and availability as provided for the equivalent WBS Service elements supplied to all Access Seekers, including the option of choosing the preferred ONT set-up, such as bridge-mode or managed mode.
- 5.2.3 The Access Provider shall provide the Access Seeker with full visibility on the ONT and ONT management and the Access Seeker shall have TR69 capability extended where the ONT is (a) supplied by the Access Provider; or (b) self provided by Access Seeker. For the purpose of this clause, the Parties shall agree on the logical demarcation and responsibility matrix for ONT management as provided in the Joint Working Manual.

SCHEDULE 6.2

SERVICE DESCRIPTION WHOLESALE DATA CONNECTION SERVICE (WDC)

1. THE SERVICE

- 1.1 The Wholesale Data Connection (**WDC**) Service provides symmetric, synchronous, dedicated and uncontended data connectivity within the Kingdom of Bahrain between:
- (a) two of the Access Seeker's Points of Presence; or
 - (b) an Access Seeker's Point of Presence and its End User Premises; or
 - (c) an Access Seeker's Point of Presence and the Point of Presence of another Licensed Operator; or
 - (d) Point to point between two End User Premises of the same Access Seeker with an additional 50% premium charge on the MRC of the requested WDC bandwidth.
- 1.2 The WDC Service can only be used with an Access Provider Customer Premises Equipment at either the Access Seeker's Point of Presence or End User Premises.
- 1.3 The WDC Service is provided with a number of options. These are specified in Annex 1 of this Service Description.
- 1.4 The WDC Service provides the following service characteristics:
- (a) Round Trip Delay (Frame Transfer Delay): 2ms
 - (b) Jitter (Frame Delay Variations): 1ms
 - (c) Frame Loss Ratio: 0%
- 1.5 The service characteristics set out at paragraph 1.4 above are tested as part of the acceptance criteria during the testing validation of a new WDC Service. The parties agree that these service characteristics are not continuously or repeatedly monitored and/or tested once the WDC Service commissioned and in service.

2. DEFINITIONS

Aggregation Link means the connectivity established between a Point of Presence of the Access Seeker and an Access Provider access node, as further detailed in Annex 2 and Annex 3 of this Service Description.

Connection means an individual WDC Service as described in paragraph 1.1.

Customer Premises Equipment or CPE means the Equipment more particularly specified under Annex 2 (Technical Characteristics) of this Service Description.

JUMBO frame means an Ethernet frame with a payload greater than the standard MTU of 1,500 bytes.

Minimum Service Period means an applicable minimum period of twelve (12) calendar months for which the WDC Service shall be provided, such period commencing from the Service Commencement Date except for a WDC Service subject to Temporary Service Period(s).

MTU means a Maximum Transmission Unit.

Point of Presence means a permanent physical location where an aggregation link or connection of a relevant Service is terminated at premises owned or leased by the Access Seeker or at the Access Provider's colocation facility, but for the avoidance of doubt cannot be an earth station, manhole, power room, lead-in pipe, duct, outdoor cabinet, MDF, riser room or anywhere not on the main island of Bahrain unless connected by a permanent physical connection above sea level and accessible to the Access Provider.

Project means a mutually agreed project plan and delivery schedule for fifteen (15) or more WDC Connections, which are subject to an agreed project plan and delivery schedule, including but not limited to specific service levels, as agreed between the Access Seeker and the Access Provider. For the avoidance of doubt, an Access Seeker is not required to opt for a Project and the Service Levels set out in Schedule 7 shall continue to apply.

Relocation means geographically shifting a WDC Service from at least one permanent physical location to another where: (i) the identity of the End User remains the same for the scenario set out at paragraphs 1.1(b) and 1.1(d) above; and (ii) the identity of the Licensed Operator remains the same for the scenario set out at paragraph 1.1(c) above.

Renewed Minimum Service Period means an applicable minimum period of one (1) calendar month for which the WDC Service shall be provided, such period commencing from the expiry of a Service Period.

Service Period means the Minimum Service Period or Renewed Minimum Service Period.

Temporary Service Period means a period of a minimum one (1) week and a maximum three (3) months for which a WDC Service or WDC Amended Service is requested.

WDC Amended Service means a WDC Service that is amended by a Change Request.

WDC Operations Manual means Annex 6 of this Schedule 6.2.

3. Supply of Service

- 3.1 A WDC Service shall be requested by the Access Seeker in the manner and according to the process set out in Annex 6 of this Schedule 6.2 – the WDC Operations Manual.
- 3.2 Subject to any Project agreed between the Access Seeker and the Access Provider, the Service Level Terms shall apply to:

- (a) New Connection - provide a new WDC Service as requested by the Access Seeker;
 - (b) Upgrade or Downgrade;
 - (c) Reconfiguration - reconfigure technical parameters of an existing Connection; and
 - (d) Cancellation - the Access Seeker requests the cessation of an existing Connection.
- 3.3 Where an Access Seeker deploys multicasts in the Access Seeker's core Network, the Access Seeker shall be able to use the WDC Service to pass multicast traffic over the Access Provider's Network transparently.
- 3.4 The WDC Service shall support MTU and JUMBO frames. Where required by an Access Seeker, the WDC Service shall support 1,700 byte frames.
- 3.5 The Access Provider shall provide access to an online tool that identifies up-to-date accurate digital coverage maps for the areas in the Kingdom of Bahrain covered by the WDC Service and the maximum speed supported for each block (or as another unit as may be introduced by the Access Provider at any point in time) to ensure that the right service is offered by the Access Seeker to the End User. This online tool should be updated at least on a monthly basis. The Access Seeker may not resell the WDC Service or any part thereof (whether logically or physically) to another Licensed Operator.

Temporary Service Period

- 3.6 The Access Seeker may request the Access Provider to provide a WDC Service or WDC Amended Service for a Temporary Service Period ('**Temporary WDC Service**'). The Access Provider shall provide the Access Provider with sufficient technical detail to allow the Access Provider to review such request.
- 3.7 The Access Provider may reject a Temporary WDC Service if, the Temporary WDC is not operationally, economically or technically feasible. The Access Provider reserves the right to reject the Temporary WDC Service if its duct network and/or civil infrastructure does not extend to the location where the Temporary WDC Service is being requested for.
- 3.8 Where the Access Provider agrees to provide a Temporary WDC Service, the parties agree that such Temporary WDC shall be subject to the charges set out in Schedule 3 – (Pricing).
- 3.9 The Access Seeker may request a renewal of the Temporary WDC for one or more Temporary Service Period(s) and agrees that such renewal shall be subject to the same charging mechanism as set out in paragraph 3.8 above. The Access Provider may reject a renewal of a Temporary WDC if it considers that such renewal is not operationally, economically, or technically feasible.
- 3.10 Where the Access Provider receives multiple requests from multiple Licensed Operators for Temporary WDC Services and where such Temporary WDC Services are to be deployed in

the same area, during the same time period and for the same event, the Access Provider shall publish its proposal for the aforementioned event and make such proposal available to all eligible Licensed Operators on a non-discriminatory basis.

General Provisions

- 3.11 Withdrawal of a speed as a result of any amendment to this Service Description approved by the Regulator will not affect the unexpired portion of any Service Period of a WDC Service unless the Access Provider is willing to Upgrade the product for the same Charge.
- 3.12 The technical specifications of the WDC Service and protection options available for the WDC Service to Access Seekers are set out in Annex 1 and Annex 2 to this Service Description.
- 3.13 Upon request from an Access Seeker and where other ingress ports are available on the Customer Premises Equipment, the Access Provider shall allow an Access Seeker to ingress its traffic for the same WDC Connection the Customer Premises Equipment was provided for on the other ingress ports of the Customer Premises Equipment (free of charge) provided for a WDC Connection or WDC Aggregation Link.
- 3.14 The Access Provider shall provide to the Access Seeker a monitoring tool, which shall enable the Access Seeker to monitor the WDC Service against the following minimum parameters and other monitoring parameters in accordance with the technical parameters defined in the Joint Working Manual. This monitoring tool shall provide monitoring facilities 24 hours a day, 7 days a week, 365 days a year. The minimum parameters shall include:
- (a) Link availability;
 - (b) Bandwidth Utilisation;

Amendment to the WDC Service

- 3.15 The Access Seeker shall be entitled to amend a WDC Service by requesting a WDC Amended Service in the manner and according to the process set out in Annex 6 of this Schedule 6.2 – the WDC Operations Manual.
- 3.16 The Access Seeker shall not be liable for any termination or additional recurring charges in respect of a request for a WDC Amended Service which is for a relocation. The Access Provider shall charge a once off charge in accordance with Schedule 3 - (Pricing) of the Reference Offer for the relocation unless the Access Seeker requires both Connections to be operational in parallel. The Access Provider shall not terminate the Connection which is subject to relocation until the Service Commencement Date of the new Connection.

Access Seeker Obligations

- 3.17 This Schedule 6.2, and more generally the Reference Offer, does not create any obligation nor any legal relationship between Access Provider and the Access Seeker's End User. This Schedule 6.2, and more generally the Reference Offer, does not provide, grant or confer any right, benefit or privilege on any of the Access Seeker's End User against the Access Provider.
- 3.18 The Access Seeker shall provide the Access Provider with suitable space for, and access during Working Hours to, any Access Provider Equipment required to be located in any building in which the WDC Service is located within the control of the Access Seeker. If consent is required from a third party, such as the building owner, the Access Seeker shall procure such consent. The Access Provider is not required to pay the Access Seeker for the preparation or use of, or access to, space provided pursuant to this sub-paragraph.
- 3.19 Where an End User Premises is a VIP location in the Kingdom of Bahrain which is not subject to the exemption under the Law, the Access Seeker may request use of the Access Provider VIP team (free of any additional charge), if the Access Seeker can provide to the Access Provider a written valid official justification for the need for such services from the Regulator or an equivalent authority. On or before receipt by the Access Provider of the written valid official justification, the Service Request shall be suspended pending receipt of a written confirmation of the approval or if is not received within thirty (30) days of the Service Request, a cancellation.
- 3.20 If the Access Provider's Equipment requires electricity supply and electricity connection points, they shall be supplied, in the location specified by the Access Provider, by the Access Seeker at the Access Seeker's expense according to the equipment specification. Such electricity shall be available at the same level of supply, protection and continuity as that available to the Access Seeker's or End User's Equipment, as appropriate.
- 3.21 The Access Seeker shall be solely responsible for any loss, theft or destruction of, or damage (reasonable wear and tear excepted) to the Access Provider's Equipment required to be located in the building where the WDC Service is provided and which is within the control of the Access Seeker or End User, occurring any time and howsoever caused (unless caused by the Access Provider or its agents).
- 3.22 The Access Seeker shall provide the Access Provider and any authorised employee, agent, affiliate or contractor of the Access Provider with all information and assistance that person may reasonably require to design, test, commission and maintain the WDC Service (which may include participation in testing procedures as and when reasonably requested by the Access Provider).
- 3.23 The Access Seeker may require their agent to be present during the installation, testing or commissioning done by the Access Provider but not so as to affect the Service Commencement Date.

Variation or Withdrawal

- 3.24 The Access Provider may upon providing three (3) months' written notice to the Access Seeker and subject to the approval of the Regulator, vary the WDC Service or withdraw the WDC Service relating to the terms and Annexes in this Service Description, by issuing a revised Service Description.
- 3.25 Notwithstanding paragraph 3.24 above, unless the Access Provider and Access Seeker agree otherwise at the time, any withdrawal or variation of the WDC Service, or any amendment to the Charges payable for the WDC Service in accordance with this Service Description and Schedule 3 – (Pricing) of the Reference Offer, shall also apply to existing WDC Services provided under the Supply Terms, which shall continue in force in accordance with its terms and conditions until renewed or terminated in accordance with this Service Description or the Supply Terms.

Maintenance and support

- 3.26 The Access Provider shall provide maintenance and support services in respect of the WDC Service in accordance with the Schedule 7 – (Service Levels) of the Reference Offer.

Protection

- 3.27 The Access Provider shall provide default logical protection for the WDC Aggregation Link at no charge.
- 3.28 The Access Seeker may procure a full geo-redundant link as protection. The geo-redundant link is considered as a separate WDC Connection and charged at the applicable MRC as set out in Schedule 3 of the Reference Offer.
- 3.29 For the avoidance of doubt, the protection at the core network level is not charged to the Access Seeker and is only provided for information purposes and may be changed at the Access Provider's sole discretion.
- 3.30 The provision of the full geo-redundant link as protection is subject to availability, feasibility study and subject to the Access Seeker obtaining any relevant approval, including but not limited to access approvals, from the End User, any relevant landlords and/or Government authority as long as the Access Provider made all reasonable efforts to obtain them, including making the relevant applications in a timely manner, notifying the Access Seeker of such requirement and keeping the Access Seeker updated on the progress.
- 3.31 During the provisioning of a WDC Connection for which a full geo-redundant link as protection is required, the Access Provider shall provide the Access Seeker with the technical details regarding the protection solution, including the following:

- (a) the service configuration;

(b) the relevant acceptance tests for both the primary and secondary end-to-end WDC Connections at RFS (after provisioning).

3.32 If the Access Seeker has more than one WDC Aggregation Link and requires a WDC Aggregation Link with protection, the Access Seeker should indicate for such WDC Connection:

- (a) the WDC Aggregation Link that will be the primary Aggregation Link;
- (b) the WDC Aggregation Link that will be the secondary Aggregation Link (in stand-by mode); and
- (c) the capacity that should be reserved on the secondary WDC Aggregation Link. This capacity will be guaranteed in case of failure of the primary WDC Connection.

4. CHARGES

4.1 The Access Seeker shall pay to the Access Provider the relevant Charges determined in accordance with Schedule 3 – (Pricing) of the Reference Offer.

4.2 All Charges and sums due from one party to the other under this Agreement are exclusive of VAT. Any VAT shall be charged in accordance with the relevant regulation in force at the time of making the taxable supply and shall be paid by the paying party following receipt from the billing party of a valid VAT invoice.

5. SERVICE LEVELS

5.1 The Access Provider shall provide the WDC Service in accordance with the Service Levels specified in Schedule 7 – (Service Levels) of the Reference Offer.

ANNEX 1 - CIRCUIT SPEEDS, DEFINED INTERFACES, MEDIA AND TOPOLOGY

Service element	Speed	Interface	Connector	Topology	Access
Connection terminating at End- User Premises or Point of Presence	64 Kbit/s to 1000 Mbit/s, STM1	Gigabit Ethernet 1000BASE-LX Gigabit Ethernet 1000BASE-SX, SDH	SC/LC	Ethernet service point-to-point/ Synchronous Digital Hierarchy (SDH)	Fibre
	1.25 Gbit/s to 10 Gbit/s, STM4, STM16, STM64	10GE:10G BASE –SR, 10G BASE LR, 10G BASE –ZR, 10GE LAN, 10GE WAN, SDH			
	25 Gbit/s	25 GE	SC/LC	Ethernet service point-to-point	
	50 Gbit/s	50 GE			
	100 Gbit/s	100 GE/OTU4			
Aggregation Link terminating at the Point of Presence of the Access Seeker	1 and 10 Gbit/s	Gigabit Ethernet 1000BASE-LX Gigabit Ethernet 1000BASE-SX	SC/LC	Ethernet service point-to-point	Fibre
Aggregation Link terminating at the Point of Presence of the Access Seeker	100 Gbit/s	Ethernet	SC/LC	Ethernet service point-to- point	Fibre

* SDH speeds, interfaces and topology are strictly limited to existing circuits or circuits that are currently on the Access Seeker's own infrastructure and subject to a service migration to BNET's network following an asset transfer exercise.

ANNEX 2 - TECHNICAL CHARACTERISTICS

Service Type	Service Attribute		
Ethernet service point-to-point or Ethernet service point-to-multipoint (Pseudowire Ethernet tagged mode with port-based aggregation or virtual aggregation) providing guaranteed symmetrical bandwidth	Interface	Optical Access: 1. GE:1000BASE-SX , 1000BASE -LX. 2. 10GE:10G BASE –SR, 10G BASE LR, 10G BASE – ZR,10GE LAN, 10GE WAN. 3. OTU2/OTU2e/OTU4. 4. STM1, STM4, STM16, STM64	
	Connector	Fibre Access: SC/Single mode LC	
	Speed	Please refer to Annex 1	
	Mode	Duplex	
	MAC Layer Supported	Yes	
	MAC Address Learning	Yes	
	Frame Size	Fibre: Min 1518, Max 9600 (Jumbo Frame), default 1700	
	Class of Service	100% Real-Time. No Over Utilisation	
	Maximum Number of CE-VLANs	4096	
	CE-VLAN – PE-VLAN ID Map	Multiple VLAN per Connection	
	CE-VLAN ID Preservation	Yes	
	CE-VLAN COS Preservation	Yes	
	Unicats Traffic Limit	None (Copper) / Yes (Fibre)	
	Multicast Traffic Limit	None (Copper) / Yes (Fibre)	
	Broadcast Traffic Limit	None (Copper) / Yes (Fibre)	
	Protocol Treatment	Spanning Tree Protocol (STP), Rapid Spanning Tree Protocol (RSTP), Multiple Spanning Tree Protocol (MSP)	
		Pause (802.3x)	
		Link Aggregation Protocol (LACP)	
		(802.1AG),(802.1Q),(802.1D), (802.1P)	
		Marker Protocol	
All LAN Bridge Management Group Block of Protocols			
Generic Attribute Registration Protocol (GARP) Block of Protocol			
Cisco Delivery Protocol (CDP)			
Cisco VLAN Trunking Protocol (VTP)			
OAM CM/Y1731 PDUs			
Quality of Service	Round Trip Delay (Frame Transfer Delay): 2 ms Jitter (Frame Delay Variations): 1 ms Frame Loss Ratio: 0%		

* SDH speeds, interfaces and topology are strictly limited to existing circuits or circuits that are currently on the Access Seeker's own infrastructure and subject to a service migration to BNET's network following an asset transfer exercise.

The Access Provider shall include multiple CPE options, to include CPE options which are available from alternative vendors. The Access Provider must apply the same Service Levels, and reserves the right to vary the CPE from time to time.

Core Layer (For information purposes only)

- BNET's network enhancement now enables Ethernet VPN (EVPN), allowing the deployment of traffic balancing and flexible deployment on Ethernet.
- The EVPN data is transported through Segment Routing over IPv6 (SRV6) technology on SRV6, ensuring that BNET's core network is able to provide the redundancy and protection required on multiple nodes in a single or multiple (GEO) physical sites.
- As such, this allows BNET to mitigate any single point of failure on its core network by allowing the traffic to be dynamically routed in case of any outage.

ANNEX 3 - AGGREGATION LINK TECHNICAL SPECIFICATIONS

Where the WDC Service is provided using the Access Provider's Fibre Based Network:

The WDC Aggregation Link(s) is/are:

- (a) provided for a minimum bandwidth of 10 Gbit/s;
- (b) delivered over a fully redundant fibre path based on available protection levels specified in Annex 2 of this Schedule 6.1, and in accordance with the defined charges/premiums set out in Schedule 3 (Pricing); and
- (c) provided with default protection mechanisms, including MSP 1+1, Sub-Network Connection Protection (SNCP), and Silver auto switching of 50ms.

The regulated MRC applicable to the WDC Aggregation Link is determined in accordance with Schedule 3 – (Pricing) of the Reference Offer.

ANNEX 4 - PROVISIONING VALIDATION TEST

The following provisioning validation test will only be carried out for the WDC Service where the WDC traffic handed over by the Access Seeker to the Access Provider is Ethernet traffic:

Provisioning Validation Test	
Testing Methodology	ITU-T Y.1564
Testing Mode	Layer 1-2 Loopback test. Tester simulates CPE
Parameters tested	Throughput, Frame loss, Latency & Jitter
Tester Speed Setting	WDC Service Speed
Tester Frame Size	Configuration & Performance Test Frame Size = 9600
Acceptance criteria	Link verification using the ITU-T Y.1564 methodology Minimum test time is 15 minutes.
Test Results	Copy provided to the Access Seeker upon request at time of testing

ANNEX 5 - WDC SERVICE DIAGRAM AND IMPLEMENTATION INFORMATION

Access Seeker's Point of Presence and the Point of Presence of another Licensed Operator, Or Two of the Access Seeker's Points of Presence;

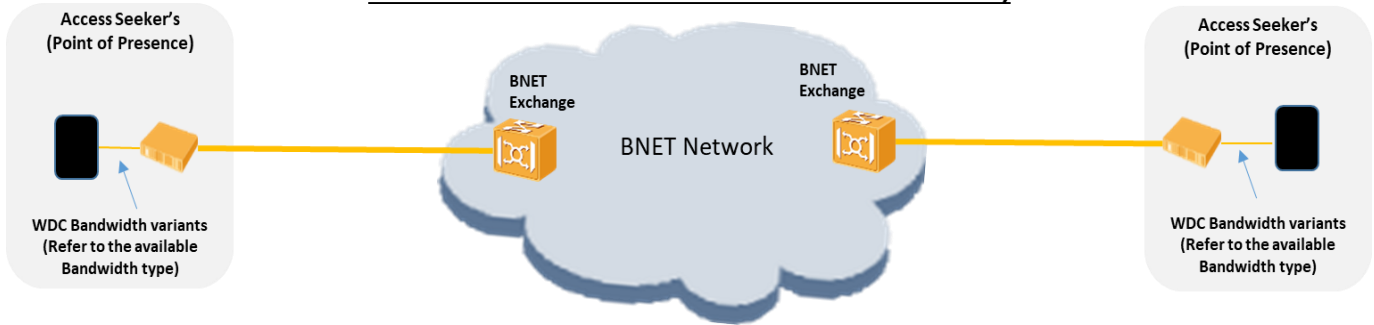

Access Seeker's Point of Presence and its End User Premises

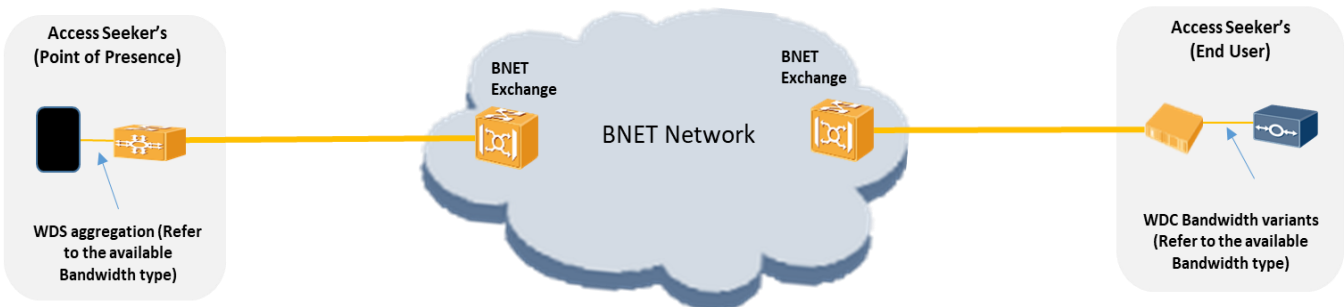

Point to Point of an Access Seeker's End Users

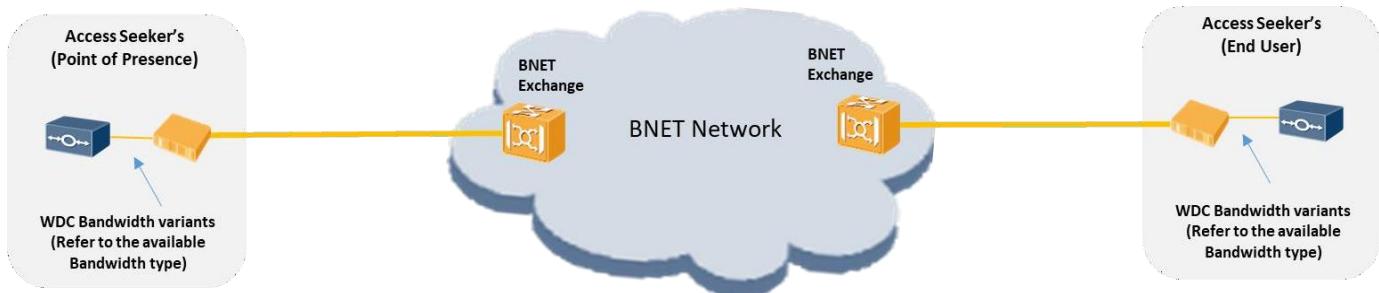

LEGENDS:

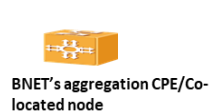

ANNEX 6 TO SCHEDULE 6.2

Wholesale Data Connection (WDC) Service Operations Manual

This document describes the onboarding, provisioning, fulfilment and fault handling process for the Wholesale Data Connection Service between the Access Provider and the Access Seeker. This document forms an integral part of the Access Provider's Reference Offer and of Schedule 6.2.

1. Onboarding

1.1 Onboarding Requirements

1.1.1 Access Seeker Onboarding

- (a) The Access Seeker shall review, acknowledge, and sign for Access Provider's counter signature the Supply Terms (Schedule 9) of the Reference Offer.
- (b) The Access Seeker shall have in force and maintain for the term of the Agreement a broad form of public liability insurance to the value of at least BD 250k and property insurance for the assets used in relation to this Agreement to the value of at least BD 100k.
- (c) These policies shall be with a licensed insurance company in the Kingdom of Bahrain and on terms and for coverage limited by only standard industry exclusions or exceptions.

1.1.2 Credit Security

- (a) The Access Seeker shall have in force and maintain security as requested by the Access Provider as required under the Reference Offer Supply Terms.

1.1.3 Licensing and Authorizations

- (a) The Access Seeker shall comply with the terms and conditions set out in the Reference Offer and relevant Service Descriptions, including obtaining any prior authorizations and shall maintain the required licenses as provided for by the Regulator.

1.1.4 Confidentiality and Non-Disclosure

- (a) The Access Seeker is required to execute the Access Provider's Non-Disclosure and Confidentiality Agreement and comply with any information protection.

1.1.5 BNET BSS

- (a) The Access Provider allows the Access Seeker to integrate via API to the Access Provider's BSS, which is designed based on the telecom standard framework for business process, the enhanced Telecom Operations Map ("eTOM"). for placement of Service Order(s) and Service Request(s).
- (b) The Access Provider also provides an interface portal (the Access Provider Portal) for Access Seeker who do not have the capability to integrate via API. The Access Provider Portal is a standard Portal that may not provide the same enhancements and benefits that an Access Seeker would receive through API integration.
- (c) The Access Provider recommends access via API integration to its BSS.

1.1.6 Process for API Integration

- (a) If the Access Seeker opts for API integration, it shall contact the Access Provider Relationship Manager for API documentation.
- (b) Access Seeker will be required to undergo a trial phase for testing the API integration and will be required to sign off on the successful completion of the testing phase. Without limitation, the Access Seeker and Access Provider will confirm the following where applicable:
 - (i) The system integration has been completed;
 - (ii) The Access Seeker has portal access and credentials;
 - (iii) Network aggregation is implemented and tested;
 - (iv) A billing test on the relevant Service is confirmed; and
 - (v) Service provisioning of for the relevant Service is confirmed.
- (c) The Access Provider should ensure that all communications with the Access Seeker should be confidential and shall not be disclosed to other Licensed Operators.

2 Fulfillment

2.1 Request to Answer

- 2.1.1 The Request to Answer process is a pre-order management process. This process comprises of activities relevant to managing Access Seeker information requests across all communication channels (Access Seeker interfaces).
- 2.1.2 Specific information requests or product requests from the Access Seeker are qualified and addressed.
- 2.1.3 Pre-order Management consists of a set of functions across the API interface that enables the interaction before the Access Seeker order can be created.

2.2 WDC Address & Service Availability Check

- 2.2.1 Prior to the Access Seeker placing a Service Order for the relevant Service, it is necessary to check whether the service infrastructure is available. The Access Seeker is provided with a tool to conduct varying levels of pre-qualification checks before submitting a Service Order.
- 2.2.2 In the circumstances where the Access Seeker chooses to submit a Service Order following the pre-qualification checks, the Access Provider shall verify the Service Order through two levels of Service availability check:
 - (a) **Address Availability Check** – to identify whether the End-User address exists in the Access Provider Address database which is updated by the IGA (Information & eGovernment Authority) through their address database; **and**

(b) **Service Availability Check** – to identify whether Access Provider’s infrastructure currently exists at the End-User’s Address and can be served through the relevant Service.

2.2.3 These qualification steps identify whether the Fulfilment request raised by the Access Seeker can be accepted. Both checks can be performed using the portal and the API integration and are performed by the Access Seeker. A response from the service availability check that an address qualifies for Service Connection to the Access Provider Network should not be relied upon as a commitment that Access Seeker will be able to connect to that address. Information returned by the Access Provider BSS for service availability is current at the time the information request is made. Footprint, serviceability and serviceability date are all subject to change.

2.2.4 The details of using the portal & API integration to interact with business processes mentioned in this Operational Manual are detailed in the LO API documentation shared by Access Provider.

2.3 WDC Service Request

2.3.1 In the event neither the address nor the service availability check is successful, the Access Seeker may:

- (a) Where the address is not available on the Access Provider’s database, raise a Service Request to add the address to the Access Provider’s address database; and
- (b) Where the service availability is unsuccessful, request cost and time estimation for the delivery of the Service.

2.4 Service Requests

2.4.1 If the Access Seeker opts for any of the options set out in clause 7 above, this shall be considered as a Service Request.

2.4.2 The Access Provider will, on a monthly basis, update the address list in the Access Provider Database which the Access Seeker shall be privy to if integrated through API or through access of the Portal. This information is provided by the IGA.

2.4.3 The Access Seeker is required to provide the information requested as per the form and mandatory fields set in the Portal/API in order to submit a Service Order. It is important for the Access Seeker to adhere to these mandatory fields, or otherwise may run the risk of having its Service Request rejected.

2.4.4 If Access Seeker finds that the address does not exist through the address availability check while raising the Service Order, the Access Seeker shall be eligible to raise a Service Request through the Portal or API for an address addition.

2.4.5 Every submitted Service Request will be allocated a unique identifier for tracking and managing the Request.

2.4.6 As part of the Service Request, the Access Seeker shall input the required information as per the below list, or in accordance with the required fields set out in the Portal/API:

- (a) Flat number– To be provided for address having flat number.

- (b) Building number
 - (c) Street name
 - (d) Road Number
 - (e) Block Number
 - (f) City
 - (g) Area
 - (h) Country
- 2.4.7 Where the Access Seeker intends to procure the Service to connect an End User Premises, the Access Seeker shall provide the Access Provider with a valid End User identification (e.g CR for an enterprise registered with MOIC).
- 2.4.8 The Access Seeker is required to attach mandatory End-User proof of address documents when raising a Service Request for address addition, such as a valid address card or any documentation which may be deemed as necessary by the IGA authority to validate the End- User address.
- 2.4.9 The Access Seeker shall be responsible to ensure the validity, authenticity, and completeness of the above-mentioned attachments.
- 2.4.10 Where any of the documentation is considered as invalid, the Service Request shall be reassigned to the Access Seeker for rectification.
- 2.4.11 Where the address is validated by the IGA and accepted, such address will be updated in BNET database and the Service Request shall be closed. Whilst the address may be updated, this does not guarantee that the Service is covered. In this case, the Access Seeker may raise a Service Request for a cost assessment (please see refer to the process below on a cost assessment Service Request).
- 2.4.12 For the avoidance of doubt, if any of the above information requested as inputs from the Access Seeker have not been provided, the Service Levels in Schedule 7 of the Reference Offer will not be applicable.
- 2.4.13 The Access Seeker can issue a pre-order feasibility Service Request, which must contain the Service/product order details along with the requesting address.
- 2.4.14 The Access Seeker must verify the requesting address and the Service/product details (including but not limited to the Service/Product ID, Service feature requirements, i.e. committed bandwidth). These must be included in accordance with the mandatory fields in the Access Provider's Portal/API integration.
- 2.4.15 Upon receipt of the Service Request, the Access Provider will assess the Service Access Resources availability at the intended address location and will provide the status of Service provision in accordance with Schedule 7 of the Reference Offer.
- 2.4.16 Service Orders raised subsequent to Service Requests should refer the relevant pre-order feasibility Service Request(s).

- 2.4.17 For the avoidance of doubt, the Access Seeker's Service Request shall be rejected if:
- (a) it does not specify a valid address; or the address cannot be verified by the authority (IGA); or
 - (b) it does not provide the required inputs delineated above; or
 - (c) it does not have the authorizations provided for by its License to avail of the Service.
- 2.4.18 No service commitment or network resources reservation should be assumed to be done as a result of an unapproved cost assessment Service Request.

2.5 Order to Payment – Fulfilment of Service Orders

- 2.5.1 The Access Seeker may submit a New Connection (“New Provide”) Service Order through API integration or via the Access Provider Portal.
- 2.5.2 The Access Provider will process these Service Orders as described below:
- (a) Service Orders will only be processed during the Access Provider's Working Hours.
 - (b) The Access Provider will acknowledge receipt of the Service Order within fifteen (15) minutes of receipt of the Service Order
 - (c) For Service Orders submitted outside of Working Hours, the Access Provider shall acknowledge the Service Request within fifteen (15) minutes following the start of the first Working Hour after receipt of the Service Order.
- 2.5.3 A Service Order shall be considered invalid if:
- (a) it is incomplete or incorrect or illegible or cannot reasonably be understood;
 - (b) it does not properly identify the End User Premises;
 - (c) a valid written End User Consent cannot be produced by the Access Seeker to support the Service Order; and/or
 - (d) it resulted from a processing error.
- 2.5.4 The Access Provider shall, within two (2) Working Days, notify the Access Seeker if the Service Order is accepted or rejected and where applicable, state the required corrections. If a notification is not provided within two (2) Working Days of receipt of the relevant Service Order, the Service Order shall be deemed accepted by the Access Provider.
- 2.5.5 In the event a Service order is rejected then the Access Provider shall provide the Access Seeker with clear reasons for the rejection at the same time of the rejection and identify the changes required to enable the Service order to be accepted.
- 2.5.6 If the Access Seeker submits a Cancellation Request after three (3) or more Working Days from the Notification of Expected RFS Dates and where this is not related to delay in the Date or Actual RFS Date by the Access Provider, the Access Seeker shall (subject to receipt of an appropriate invoice) be liable to pay one (1) MRC to the Access Provider.

- 2.5.7 Within five (5) Working Days from the date of the acceptance of the Service Order, the Access Provider shall notify the RFS Dates to the Access Seeker, as specified in Schedule 7 – (Service Levels) of the Reference Offer. The Access Provider reserves the right to reject the Service Order during this stage if it is found that the WDC Service is not supported or if the Access Provider's point to point Service Access Resources Network does not extend to the requested area within the Kingdom of Bahrain.
- 2.5.8 The Access Seeker shall book service installation initial appointment within 2 working days for service installation once RFS date is notified to Access Seeker. If the Access Provider's technician shall be present at the End User Premises to install a WDC Service, and if, for any reason, the Access Seeker and/or the End User cannot be available on the Expected RFS Date for such installation, the Access Seeker shall give the Access Provider a minimum written notice of two (2) Working Day. The revised Expected RFS dates are then set following the below principles:
- (a) The Access Seeker shall propose the next earliest date(s) for installation appointment which the Access Provider's technician would be available for the installation which shall be a maximum of two (2) Working Day notice from the day of the missed appointment.
 - (b) The previously notified Expected RFS Date is also modified and is set apart from the revised Expected RFS Date by the Maximum Validation Time of three (3) Working Days. The revised Maximum RFS Date is then set equal to the revised Expected RFS Date.
 - (c) The Access Provider shall send the Access Seeker a Notification of revised Expected RFS Date.
- 2.5.9 In addition, if at least one of the following two conditions is met (i) the Access Seeker does not provide the Access Provider a minimum written notice of two (2) Working Days to inform of its unavailability; or (ii) the Access Provider sends a technician who is not able to access the site to install the WDC Service, then except for the cases of Force Majeure affecting the Access Seeker, the Access Seeker is liable to pay the installation and configuration charge for the requested WDC Service as specified in Schedule 3 - (Pricing) of the Reference Offer. In such case, the modification and Notification of the revised Expected RFS Date and the revised Maximum RFS Date follow the same principles as described in paragraph 2.5.8.
- 2.5.10 The Access Provider's technician shall attend and access the Access Seeker's site or the End User Premises during Working Hours and at least have called the Access Seeker's representative, if it appears that the Access Seeker's technician is not present at the relevant time (and where requested provide evidence of this). The Access Seeker shall, in this case, be liable to pay only the incurred man-day costs of the Access Provider technician.
- 2.5.11 In addition, if the Access Provider does not provide the Access Seeker with a written notice of a minimum of two (2) Working Days to rearrange a site visit under paragraph 2.5.10 above, then the Access Provider is liable to waive an amount equal to one installation and configuration charge for the WDC Service.

2.5.12 Subject to the Access Seeker fulfilling its obligations set out in service description, the Access Provider shall provide, and the Access Seeker shall acquire the WDC Service either within the standard timescales or by the Exceptional Delivery Date as appropriate.

2.5.13 Where the Access Provider has accepted a Service order which requires the deployment of Service Access Resources in a particular area, the Access Provider may also seek to recover the costs of such deployment through an NRC. Such instances shall be determined on an ad-hoc basis and include, but are not limited to, the following examples:

			Further details
1	Business building or enterprise customer Premises	Deploying a new Service Access Resources cable (In addition, construction of new ducts and other underground infrastructure may be required in some sections).	<p>The Access Provider shall recover the costs incurred in building the portion of Service Access Resources which corresponds to the path from the building to the nearest street/road where an existing duct is available.</p> <p>Additional underground infrastructure (e.g. handhole or manhole) built on the main duct path in the street/road and used to connect to the building are deemed excluded from the recoverable costs as long as they fall within fair and reasonable amounts and will be recovered through the MRC</p> <p>In cases where the portion of civil works per Service Access Resources is found to be exceeding the fair and reasonable boundaries, excess construction charges shall be applied on a time and material basis as defined in Schedule 3 (Pricing) of the Reference Offer subject to agreement between BNET and the LOs</p> <p>Payment by the Access Seeker should be made against the Access Provider's submission of an itemized invoice and a map detailing the work performed.</p>
2	Deployment of a Service Access Resources protection (i.e. path redundancy).	Deploying a redundant Service Access Resources path to a location (In addition, construction of a new duct lead-in, new ducts and other underground infrastructure may be required in some sections).	<p>The Access Provider shall be able to fully recover the costs incurred in deploying a new Service Access Resources protection path by charging the Access Seeker an NRC. Payment by the Access Seeker should be made against the Access Provider's submission of an itemized invoice and a map detailing the work performed.</p>
3	Deployment of Service Access Resources access within privately owned property.	Deployment of Service Access Resources within privately owned property (In addition to the Service Access Resources cable, construction of new ducts and other infrastructure may be required e.g. distribution panel and boxes, Service Access Resources cables in risers etc.).	<p>The Access Provider shall be able to fully recover, on a time and material basis, the costs incurred in deploying a Service Access Resources within a privately owned property by charging the Access Seeker an NRC. Payment by the Access Seeker should be made against the Access Provider's submission of an itemized invoice (broken down by time and materials) and, if available, a map detailing the work performed.</p>

- 2.5.14 A Service Order shall be considered invalid if:
- (a) it is incomplete or incorrect or illegible or cannot reasonably be understood;
 - (b) it does not properly identify the End User Premises;
 - (c) a valid written End User Consent cannot be produced by the Access Seeker to support the Service Order; and/or
 - (d) it resulted from a processing error.
- 2.5.15 At the time of rejection, the Access Provider shall provide sufficiently detailed written reasons for rejection to the Access Seeker.
- 2.5.16 The SLAs in schedule 7 shall only be applicable to forecasted Service Orders in line with Schedule 5 (Forecasting) of the Reference Offer.
- 2.5.17 A Service Order must be in the format notified by the Access Provider from time to time and be submitted through an online digital interface notified to the Access Seeker by the Access Provider, from time to time.
- 2.5.18 Only in the case where the online digital Portal or the API integration setup mechanisms are not accessible, electronic mails shall be accepted as a communication mechanism.
- 2.5.19 The Access Seeker's Billing Account must be active and not in a suspended state in order for the Access Provider to accept and proceed with the Service Order.
- 2.5.20 End-User permissions & site readiness is the responsibility of Access Seeker to communicate to the Access Provider.
- 2.5.21 The time slots with regard to appointment rebooking will be made available to the Access Seeker two days from the date of initiating the re-booking of appointment.

Projects

- 2.5.22 For New Connections of more than fifteen (15) sites, the Access Seeker may request the Access Provider to consider such New Connections as one Project. Subject to agreement between the Access Seeker and Access Provider, the Project will be managed based on an agreed project plan between the Access Provider and Access Seeker.

2.6 Request to Change

- 2.6.1 In the event the Access Seeker elects to reschedule or cancel a Service Order past the point-of-no-return, the Access Seeker shall be charged rescheduling or cancellation charges in line with Schedule 3 (Pricing) if the rescheduling/cancellation request is made twenty-four (24) hours from the appointment date provided to the Access Seeker by the Access Provider. In such cases, the Service Levels set out in Schedule 7 shall be suspended until the appointment is booked.
- 2.6.2 The point of no-return shall be defined as the instance when the appointment date has been provided to the Access Seeker by the Access Provider, and prior to any visits made by the Access Provider to the End User Premises.
- 2.6.3 To initiate a change to an existing WDC Service used by the Access Seeker to supply a service to an End User, the Access Seeker shall provide the Access Provider with a properly completed WDC Change Request, in the format notified by the Access Provider from time to time, submitted by electronic mail (or other electronic format, which may include an online digital interface) to the address notified to the Access Seeker by the Access Provider, from time to time.
- 2.6.4 In addition to the rejection reasons set out at paragraph 2.5.7 the Access Provider may also reject a WDC Change Request if it is not submitted in accordance with paragraph 2.5.14.
- 2.6.5 The Access Provider may, in its sole discretion, elect to accept any WDC Change Request notwithstanding that there is any defect in that WDC Change Request, if the Access Provider considers that such defect does not have a material effect on the Access Provider's ability to process the WDC Change Request and provide the WDC Service. A WDC Change Request may comprise of any of the following:
- (a) External Relocation
 - (b) Internal Relocation
 - (c) Upgrade
 - (d) Downgrade
- 2.6.6 The Access Seeker shall submit the request to Access Provider for an internal relocation of the WDC Service, which comprises of the relocation of an Access Provider's CPE inside the End User Premises/PoP to another location within the same End User Premises/PoP. The Access Provider shall charge a once off charge in accordance with Schedule 3 – (Pricing) of the Reference Offer for the internal relocation of the existing WDC Service.
- 2.6.7 The Access Seeker shall send the request to the Access Provider for the external relocation or relocation of the WDC service, which will follow the same process of SLA criteria as new connection.

- 2.6.8 The Access Seeker shall not be liable for any termination or additional recurring charges in respect of a request for a WDC Amended Service which is for a relocation. The Access Provider shall charge a once off charge in accordance with Schedule 3 - (Pricing) of the Reference Offer for the relocation unless the Access Seeker requires both Connections to be operational in parallel. The Access Provider shall not terminate the Connection which is subject to relocation until the Service Commencement Date of the new Connection.
- 2.6.9 The Access Seeker shall be entitled to amend a WDC Service by requesting a WDC Amended Service where this is an Upgrade by providing an Upgrade Request to the Access Provider. The Access Seeker shall only be entitled to Downgrade the throughput of a Connection till the Minimum Service Period has expired. Where the Access Seeker requests a WDC Amended Service, then the Service order procedure set out in this Service Description shall apply to that request.
- 2.6.10 The Access Seeker shall not be liable for any termination or additional recurring charges in respect of a request for a WDC Amended Service which is for a relocation. The Access Provider shall charge a once off charge in accordance with Schedule 3 - (Pricing) of the Reference Offer for the relocation unless the Access Seeker requires both Connections to be operational in parallel. The Access Provider shall not terminate the Connection which is subject to relocation until the Service Commencement Date of the new Connection.
- 2.6.11 The Access Provider will provide an RFS date with regard to an external relocation that is not within the Forecasted Orders and where the new intended address is not covered by Service Access Resources. For the avoidance of doubt, the SLAs in Schedule 7 will not apply to these Service Orders.
- 2.6.12 For any service upgrade that is not within the Access Seeker's forecasted Service Orders, the SLAs denoted in Schedule 7 will not apply, and the Access Provider shall provide an RFS date based on network capacity availability.

2.7 Exceptions

- 2.7.1 The Access Provider shall, subject to the exceptions, limitations and conditions specified in this Service Description and/or Supply Terms, provision and deliver the WDC Service on or before the RFS Date and in accordance with Schedule 7 - (Service Levels) of the Reference Offer.
- 2.7.2 The Parties acknowledge and accept that exceptional circumstances, such as those set out below, may give rise to delays in any stage of the provisioning and delivery of a Service Order. If the occurrence of any of the events below takes place, the Access Provider shall communicate the Exceptional Delivery Date to the Access Seeker and shall not be held liable for the Service Level Penalties. The exceptional circumstances shall only comprise of:
- (a) a Force Majeure Event or a Regulatory Event; or
 - (b) Emergency Maintenance; or

- (c) any material breach of the Access Seeker's obligations.
- (d) The Access Provider shall, in notifying the Access Seeker of the Revised Delivery Date, provide sufficient evidence to justify the reasons for the delay of the delivery.

2.7.3 The Access Provider shall not be obliged to further process a Service Order where:

- (a) the relevant WDC Service cannot meet Service Qualification; or
- (b) following the provision of reasonable notice by the Access Provider, an authorized person from the End User or the Access Seeker is not available to provide further information when requested.

2.8 Notification of Completion of Order

2.8.1 The Access Provider shall, on the same Working Day of completion of a Service Order, notify the Access Seeker of completion.

2.8.2 In the case of a Service Order, the Access Provider is entitled to rely on an evidence that the relevant End User:

- (a) has given a valid End User Consent in relation to the requested Service Order; and
- (b) in the case of a Change Request understands and has requested the Change.

2.9 Termination to Confirmation

2.9.1 Where the Minimum Service Period has not expired, the Access Seeker shall be entitled to terminate the WDC Service on at least one (1) month's written notice to the Access Provider and shall be liable to pay liquidated damages as calculated by the following formula.

2.9.2 Formula for calculating liquidated damages: $LD = MRC \times (12-M)$ where:

LD = liquidated damages to be paid.

MRC = Monthly Recurring Charge for the WDC Service.

M = number of months between the Actual RFS Date and the removal order date rounded-up to the next full month.

2.9.3 The Access Seeker shall not be liable to pay liquidated damages where the Access Seeker terminates the WDC Service as a result of and/or arising out of a material breach of the Reference Offer by the Access Provider.

2.9.4 The Access Seeker expressly acknowledges that liquidated damages as calculated above form a reasonable pre- estimate of the loss which the Access Provider would suffer as a result of early termination by the Access Seeker. Such liquidated damages shall be the Access Provider's sole and exclusive damages or monetary remedy for such early termination.

2.9.5 Following the expiry of any Minimum Service Period the WDC Service shall be automatically renewed for successive Renewed Minimum Service Periods unless and until terminated by the Access Seeker. During the Renewed Minimum Service Period, the Access Seeker may terminate the WDC Service

subject to providing the Access Provider with a written termination notice of at least one (1) month prior to the expiry of the Renewed Minimum Service Period. In the event that the Renewed Minimum Service Period expires, and the Access Seeker does not provide any written termination notice as above, the WDC Service shall renew for a further Minimum Service Period.

- 2.9.6 The Access Provider may upon providing three (3) months' written notice to the Access Seeker and subject to the approval of the Regulator, vary the WDC Service or withdraw the WDC Service relating to the terms and Annexes in this Service Description, by issuing a revised Service Description.
- 2.9.7 Unless the Access Provider and Access Seeker agree otherwise at the time, any withdrawal or variation of the WDC Service, or any amendment to the Charges payable for the WDC Service in accordance with this Service Description and Schedule 3 – (Pricing) of the Reference Offer, shall also apply to existing WDC Services provided under the Supply Terms, which shall continue in force in accordance with its terms and conditions until renewed or terminated in accordance with this Service Description or the Supply Terms

3 Fault Handling and Resolution

3.1 Faults

- 3.1.1 The Access Provider's responsibility for faults in the WDC Service is limited to the following:
- (a) Any fault that affects the WDC and/or in the Access Provider's Network, Systems, Access Provider Equipment where such fault is not caused, whether directly or indirectly, by the Access Seeker's actions or omissions;
 - (b) Any fault that the WDC and/or in the Access Provider's Network, Systems, Access Provider Equipment where such fault is directly caused by the Access Provider's action or omission.
- 3.1.2 The Access Seeker is responsible for any fault that affects the WDC and/or in the Access Provider's Network, Systems, Access Provider Equipment where such fault is caused, whether directly or indirectly, by the Access Seeker's actions or omissions, whether through negligence or otherwise.
- 3.1.3 The Access Seeker shall be responsible for providing an initial fault diagnosis and reporting for any fault reported to the Access Seeker by its End-Users. The Access Seeker must ensure that its fault reporting service is competent and sufficiently resourced as per the quality standards set in the industry.
- 3.1.4 Pursuant to paragraph 0 above and prior to notifying the Access Provider of a fault, the Access Seeker must:
- (a) Confirm the presence of a fault;
 - (b) Perform an initial fault diagnosis to identify where the fault has arisen;
 - (c) Use all reasonable endeavors to investigate the fault and find out all relevant information from its End-User;

- (d) Confirm that the fault falls under the Access Provider's responsibility with a clear explanation as to why it considers this to be the case.
- 3.1.5 When the Access Seeker has met the conditions set out in paragraph 0 above, it must report any fault that the Access Provider falls under the Access Provider's responsibility, as set out in paragraph 3.1.1 above, to the Access Provider and provide reasonable information regarding the fault by raised a Customer Problem ticket.
- 3.1.6 If the fault is found to be outside of the Access Provider's responsibility, as set out in paragraph 3.1.1 above, or where the Access Provider cannot confirm the presence of a fault, the Access Provider may charges the Access Seeker on a time and materials basis.
- 3.1.7 The Access Provider will not accept any report of a fault from End User of the Access Seeker. Any End User of the Access Seeker mistakenly contacting the Access Provider will be advised to contact the Access Seeker. The Access Seeker must ensure that all its End Users are informed that all faults must be reported to the Access Seeker.

3.2 Fault Resolution

- 3.2.1 The Access Seeker will facilitate contact with any relevant End User of the Access Seeker and/or arrange a site visit this is reasonably required by the Access Provider to clarify the nature of, or undertake work to fix, any Reported Fault. the Access Provider may communicate End User of the Access Seeker directly so long as such communications are confined to technical matters directly concerning the Reported Fault.
- 3.2.2 Upon the Access Provider' acknowledgement of a Reported Fault that is the Access Provider' responsibility, the Access Provider will:
 - (a) diagnose and fix the Reported Fault;
 - (b) following the initial diagnosis, provide an indication to the Access Seeker of the likely time to fix the Reported Fault (Response, provided that the Access Provider has no obligation to provide such indication if the Reported Fault is fixed at the time of initial diagnosis.

3.3 Reporting Faults to the Access Provider

- 3.3.1 The Access Provider has two automated channels which allows the Access Seeker to create customer trouble tickets:
 - (a) Portal
 - (b) API Integration
- 3.3.2 The two channels allow Access Seekers to:
 - (a) create a new trouble ticket;
 - (b) retrieve status and updates on a trouble ticket; and
 - (c) Receive ticket resolution and closure updated along with root cause.

- 3.3.3 Faults can be logged 24 hours a day, seven days a week.
- 3.3.4 The Access Seeker must use the Access Provider Portal or API Integration for reporting all faults regarding the WDC Service. If the Access Seeker uses any other method to report a fault, the fault will not be acknowledged by the Access Provider or attended and the Service Levels as defined will not apply to that fault.
- 3.3.5 Where the Access Provider advises the Access Seeker that Portal /API is unavailable, the Access Seeker must submit fault reports to the Access Provider by calling the Access Provider Call Center. The Access Provider will use all reasonable endeavors to advise Access Seekers immediately upon becoming aware that the Portal /API is unavailable.
- 3.3.6 Once the Access Seeker has provided initial fault diagnosis, determined that it requires the Access Provider assistance to resolve the fault, the following information is required when reporting a fault:
- (a) confirmation that the initial fault diagnosis has been completed;
 - (b) contact name and phone number of the Access Seeker staff member logging the fault;
 - (c) contact name, phone number, and alternate phone number of the End User experiencing the fault (where appropriate);
 - (d) End User's Service Identifier for service that is experiencing the fault (where appropriate);
 - (e) fault type and description;
 - (f) time the fault occurred;
 - (g) address and contact details for the site of the fault (where appropriate); and
 - (h) any other relevant information.
- 3.3.7 If any of the above information set out from (a) to (h) in paragraph 3.3.6 above is not provided, the Service Levels in the Schedule 7 of the Access Provider Reference Offer will not apply.

3.4 Fault Report Acknowledgement

- 3.4.1 When a fault report is received, the Access Provider will advise the Access Seeker, acknowledging receipt of the fault report within specified SLA in schedule 7.

3.5 Fault Tracking

- 3.5.1 All faults will be logged in Portal /API integration and the Access Seeker will be given a fault reference number where the access seeker can get the update on the raised trouble tickets and the progress to restore the service.
- 3.5.2 Where the Access Provider subsequently becomes apparent that the fault restoration time cannot be met, the Access Provider will advise the Access Seeker of a revised fault restoration time.

3.6 Access Seeker Site and/or End-User Premises Visit

- 3.6.1 If the Access Provider identifies the need to send a field engineer to the end-user, the Access Provider will update Access Seeker trouble ticket in portal/API integration.
- 3.6.2 The Access Seeker's is responsible for coordinating site access, visit appointment and any required outage window with the End User.
- 3.6.3 In case end-user don't respond to the Access Provider calls to confirm appointment, the KPI will be stopped and access seeker will need to re-book appointment and inform the Access Provider with new appointment booked.

3.7 Fault Types

- 3.7.1 If the issue can be fixed remotely, the Access Provider will fix the issue and the customer trouble tickets will be updated accordingly.
- 3.7.2 In the event where the issue is within passive or active resources, a planned outage will be required and the Access Provider will inform the access seeker on planning outage timings.
- 3.7.3 access seeker representative to be available at the time of the end-user visit to verify and accept the resolution of the end-user fault.

3.8 Fault Closure

- 3.8.1 Once the fault has been resolved, the Access Provider will notify the Access Seeker via Portal/API integration that the fault has been resolved, confirm the reference number and, where possible, provide the cause of the fault and any actions taken to reach resolution.

3.9 Emergency and Core Network Faults

- 3.9.1 Emergency and Core Network faults reported to the Access Provider will be treated on a case-by-case basis. In the first instance, the Access Provider will propose a temporary solution. However, in the absence of a viable temporary solution, the Access Provider may schedule a callout to respond to Core Network faults, or to emergency faults relating to mass outage that impacts an entire block or area.

4 Complaints

- 4.1 This section deals with Access Seeker enquiries where the Access Seeker is not satisfied with a product and/or handling and timeliness of an enquiry.
 - 4.1.1 Access Seekers can reach their designated account manager to report any complaint related to none-technical issues.
 - 4.1.2 Access seeker can be raise their complaints through the portal and/or API integration
 - 4.1.3 The Relationship Manager will acknowledge the receipt of the complaint within 2 working days.
 - 4.1.4 A response to the complaint will be provided to the Access Seeker within 5 working days. \

4.1.5 In case the Access Seeker finds the provided solution is not satisfactory, the complaint can be escalated to Head of relationship manager.

4.2 The Access Provider Network, the Access Provider Owned Equipment and Property.

4.2.1 For the Access Seeker's own safety, and so that services supplied by the Access Provider are not disrupted, the Access Seeker must help safeguard the Access Provider' Network and the Access Provider Owned Equipment. The Access Seeker must:

- (a) Follow the Access Provider' reasonable directions when connecting anything to the Access Provider' Network or any the Access Provider Owned Equipment
- (b) Only allow people authorised by the Access Provider to work on or around the Access Provider' Network or the Access Provider Owned Equipment; and
- (c) make sure everyone the Access Seeker is responsible for also meets these obligations.

4.3 Access Seeker Responsibility towards the Access Provider Owned Equipment

4.3.1 At the time any the Access Provider Owned Equipment is supplied, the Access Provider will use all reasonable endeavours to make sure it is safe, durable and approved for connection to the rest of the Access Provider' Network.

4.3.2 Where the Access Provider supplies the Access Seeker with any the Access Provider Owned Equipment, the Access Seeker will, where applicable:

- (a) leave the Access Provider Owned Equipment installed and not use it otherwise than in specified in the service description.
- (b) protect the Access Provider Owned Equipment from radio or electrical interference, power fluctuations, abnormal environmental conditions, theft and any other risks of loss or damage.
- (c) if the Access Provider Owned Equipment is lost, stolen or damaged, notify the Access Provider directly and pay for repairing or replacing it, except where the loss, theft or damage was caused by the Access Provider;
- (d) follow the Access Provider' reasonable directions when using the Access Provider Owned Equipment and never use the Access Provider Owned Equipment for purposes for which it is not designed; and
- (e) not encumber the Access Provider' title to the Access Provider Owned Equipment or expose such title to third Party claims and notify the Access Provider if it becomes aware of any third-Party claim.

4.3.3 When any the Access Provider Owned Equipment is no longer required the Access Seeker:

- (a) must return the Access Provider Owned Equipment to the Access Provider;
- (b) will take reasonable care to avoid causing damage when returning the Access Provider Owned Equipment to the Access Provider and be responsible for any damage to the Access Provider Owned Equipment; and

- (c) must pay all Charges for the Access Provider Owned Equipment until such time as it is returned to the Access Provider.

5 Planned Outages and Maintenance

5.1 General Obligations

- 5.1.1 The Access Provider may suspend any WDC in order to carry out Planned or Emergency Maintenance.
- 5.1.2 In the case of Planned Maintenance, the Access Provider shall use its best endeavors to carry such activity during the night or at weekends or other quiet periods.
- 5.1.3 The Access Provider shall give ten (10) Working Days' notice of each Planned Maintenance activity affecting a particular WDC Service or group of WDC Services. This shall include the circuits affected, the date and time of the suspension and the likely duration of the suspension.
- 5.1.4 The Access Provider shall give three (3) Days' notice of each Emergency Maintenance activity affecting a particular WDC Service or group of WDC Services. This shall include the circuits affected, the date and time of the suspension and the likely duration of the suspension.
- 5.1.5 In cases of Emergency Maintenance, the Access Provider shall advise the Access Seeker within five (5) hours after service is restored with a report of the cause of the Fault.
- 5.1.6 The Access Provider shall use its reasonable endeavors to take into account the reasonable operational concerns of the Access Seeker before implementing any Planned Maintenance and be carried in accordance with Schedule 7 of the Access Provider's Reference Offer.

5.2 Types of maintenance and support services

- 5.2.1 The Access Provider shall provide Network maintenance and support services, such as CPE replacement and Service Access Resources patch cord replacement, in accordance with the Service Levels set out in Schedule 7 - (Service Levels) of the Reference Offer. In the event that such replacement is required due to Access Seeker or End User misuse, the Access Provider reserves the right to re-charge the replacement cost of these equipment(s) to the Access Seeker.

SCHEDULE 6.3 - SERVICE DESCRIPTION MOBILE DATA SERVICE (MDS)

THE SERVICE

1. SERVICE DESCRIPTION

- 1.1. The Mobile Data Service (the '**MDS**') represents an input into the operations of the mobile telecommunications networks within the Kingdom of Bahrain and provides the Access Seeker with a choice between Managed or Unmanaged Connections, whereas
 - 1.1.1. **Managed MDS** (the '**MDS-M**'): involves uncontended, symmetrical, dedicated point-to-point private leased circuit/ Connection, with a CPE for service management provided by the Access Provider, between (i) an Access Seeker's Core Mobile Site and (ii) an Access Seeker's Wireless Radio Site.
 - 1.1.2. **Unmanaged MDS** (the '**MDS-U**'): involves a point-to-point link using for each MDS-U Connection a single Fiber Pair, to establish Connection(s) between:
 - a) an Access Seeker's Core Mobile Site and an Access Seeker's Wireless Radio Site, or
 - b) two different Access Seeker's Wireless Radio Sites, or
 - c) a Baseband Unit (BBU) and the corresponding Remote Radio Head (RRH) which are forming part of the Access Seeker's Mobile Network.
- 1.2. The technical characteristics of both Managed and Unmanaged MDS are specified in Annex 1 of this Service Description.
- 1.3. The MDS Service is available to Access Seekers holding an appropriate Individual Mobile Telecommunications License only.
- 1.4. The Managed MDS Service provides the following service characteristics, and these parameters are tested in the acceptance criteria during the testing validation of a new Managed MDS Connection:
 - 1.4.1. Round Trip Delay (Frame Transfer Delay): 2ms
 - 1.4.2. Jitter (Frame Delay Variations): < 1ms
 - 1.4.3. Frame Loss Ratio: 0%
- 1.5. The parties agree that these service characteristics of the Managed MDS are not continuously or repeatedly monitored and/or tested once the Managed MDS has been commissioned and in service.

2. DEFINITIONS

Capitalised terms not defined in this Service Description are defined in Schedule 8 - (Dictionary). Terms defined in this Service Description are specific to it.

Aggregation Link means the connectivity established between a Point of Presence of the Access Seeker and the Access Provider access node.

Baseband Unit (BBU) means the unit responsible for processing the baseband signals, where “baseband signal” refers to the signal from a Remote Radio Head that is unmodulated, via an optical interface. The BBU is connected to the RRH through CPRI (Common Public Radio Interface) fibre cables.

Connection means an individual point-to-point link forming part of the Mobile Data Service as described in paragraph 1.

Core Mobile Site means a location in the Kingdom of Bahrain owned or controlled by an Access Seeker which hosts equipment for mobile network control functionality (i.e. aggregate sites into platforms such as MSC, RNS, BSC or EPC, etc.) on its Mobile Network.

Customer Premises Equipment or **CPE** means:

- a) in case of Managed MDS, the Equipment forming part of the Managed MDS provided by the Access Provider only (which is the Access Provider’s Equipment throughout the Service Period and shall be collected by the Access Provider when no longer required) and located at the Wireless Radio Site more particularly specified under Annex 2 (Technical Characteristics), and
- b) in case of Unmanaged MDS, end point transport equipment connected to the Access Seeker’s mobile telecommunications network, which the party procuring such equipment and providing it to the Access Provider to use it for Unmanaged MDS shall be obliged to ensure, fully complies with all relevant standards and approvals as may be required by the Telecommunications Law and any regulations forming part of the telecommunication’s regulatory framework in the Kingdom.

Fiber Pair means, for Unmanaged MDS, a single fiber optic pair forming part of the Access Provider’s licensed fixed fibre network that is provided by the Access Provider and is connected to the CPE, which is provided either by the Access Provider or by the Access Seeker (at the Access Seeker’s choice), to establish the MDS-U Connection(s) as further described in Clause 1.1.2.

MDS Amended Service means a Managed MDS Service that is amended by a Change Request, or Unmanaged MDS following a request for External or Internal Relocation of one of its end points.

MDS Operations Manual means Annex 5 (Part (A) for Managed MDS Service and Part (B) for Unmanaged MDS Service) of this Schedule 6.3.

Minimum Service Period means an applicable minimum period of twenty-four (24) calendar months for which the MDS Service shall be provided, such period commencing from the Service Commencement Date except for the cases set out in clause 3.11 below for Temporary Managed MDS.

Remote Radio Head (RRH) means a remote radio transceiver that connects to the BBU via an optical interface.

Renewed Minimum Service Period means an applicable minimum period of one (1) month for which the MDS Service shall continue being provided following the completion of the Minimum Service Period, such period commencing after the expiry of the Minimum Service Period and being renewed automatically (and repeatedly), unless the Access Seeker decides to terminate it.

Service Period means the Minimum Service Period or any Renewed Minimum Service Period, and the Temporary Service Period for Managed MDS, where applicable.

Temporary Service Period means a period of a minimum of one (1) month and a maximum of (3) months under which an Access Seeker may request a new Managed MDS Connection or Upgrade of an existing Managed MDS Connection. Due to the nature of the Unmanaged MDS, this possibility does not apply to Unmanaged MDS.

Wireless Radio Site means a Public Radiocommunications Station located in the Kingdom of Bahrain as defined by the Telecommunications Law and the Regulation on Permitting, Installation, Upgrading and Maintenance of Public Radiocommunications Stations, as amended from time to time, owned or controlled by the Access Seeker, which is used to serve End Users with mobile telecommunications services through sectoral antennae.

3. TERMS

Use of Service

- 3.1. The MDS Service shall only be made available to:
 - 3.1.1. connect the relevant mobile network equipment located at the end point(s) described in Clause 1.1 above for the purpose of conveyance and/or routing of messages, sound, visual images or signals on mobile telecommunications network of the Access Seeker, and
 - 3.1.2. without prejudice to Clause 3.1.1, not to connect any other Point of Presence or provide other connectivity services to residential or non-residential end users or connect any other equipment or for any other purpose.
- 3.2. For Unmanaged MDS, the Access Provider shall be entitled to verify compliance of the Access Seeker's request with clause 3.1 and that each Unmanaged MDS Connection provisioned to the Access Seeker is provided over an active interface over the CPE at the time of Unmanaged MDS provisioning and before

the Commencement Date. In case of any suspected breach of this clause 3.1, the Access Provider shall be entitled to refer the matter for resolution to the Regulator.

- 3.3. Where the Access Seeker procures its own CPE to be connected to Unmanaged MDS, the Access Seeker shall provide such CPE to the Access Provider for the Access Provider to, in coordination with the Access Seeker, connect it to the respective MDS-U Connection at the time of Unmanaged MDS provisioning and enable the Access Seeker to utilise the Unmanaged MDS Connection as an active service for transmission through the CPE. The Access Seeker shall provide to the Access Provider all cooperation and assistance including for connection to the CPE and final testing reasonably necessary for purposes of delivering the MDS-U for its use by the Access Seeker as an active service. The Access Provider shall incur no liability regarding the deployment, use and connection of the CPE provided by the Access Seeker.
- 3.4. Where the Access Seeker requests the Access Provider to procure and provide the CPE to be connected to Unmanaged MDS, then the Access Provider shall be entitled to apply a Charge covering all the costs of that CPE, its installation and use by the Access Provider for the connection to the Unmanaged MDS, in addition to the other MDS-U Charges as set in Schedule 3.
- 3.5. The Access Seeker may not resell the MDS Service to another Licensed Operator.
- 3.6. Where the Access Provider at any time reasonably suspects breach of this clause 3, it may refer the matter as a complaint for investigation by the Regulator.
- 3.7. Where the Regulator establishes after an investigation under this clause 3.23 that the Access Seeker does not intend to use or is not using the Service in accordance with this Service Description, the Access Provider, without prejudice to any other rights and remedies under Schedule 9 (Supply Terms), may by immediate written notice discontinue the provision of the MDS or suspend or terminate all or part of the MDS and the Access Seeker shall be liable to pay the Access Provider liquidated damages, calculated in accordance with the process set out in the MDS Operations Manual, where applicable.

Supply of Service

- 3.8. The Access Seeker shall submit a Service Order to the Access Provider to request supply of the Managed or Unmanaged MDS Service in accordance with the terms of this Reference Offer and, in the manner, and in accordance with the process set out in the relevant MDS Operations Manual.
- 3.9. The Service Level Terms, which are distinct and separate for Managed MDS and Unmanaged MDS, shall apply to:
 - 3.9.1. New MDS Connection – provide a new Connection as requested by the Access Seeker;
 - 3.9.2. For Managed MDS: Upgrade or Downgrade;
 - 3.9.3. For Managed MDS: Cold Migration – change the Wireless Radio Site address of an existing Connection, requiring disconnection and reconnection of the Connection end point;

- 3.9.4. For Managed MDS: Reconfiguration – reconfigure technical parameters of an existing Managed MDS Connection; and
- 3.9.5. Cancellation – the Access Seeker requests the cessation of an existing MDS Connection.
- 3.10. Further information relating to the applicable Service Levels and Service Level Penalties for the above is detailed in Schedule 7 - (Service Levels) of the Reference Offer.
- 3.11. The Access Seeker may request the Access Provider to provide Managed MDS, or upgrade an existing Managed MDS, for a Temporary Service Period (“**Temporary Managed MDS**”). The Access Seeker shall provide the Access Provider with sufficient technical detail to allow the Access Provider to review such request.
- 3.12. The Access Provider may reject a request for a Temporary Managed MDS if the same is not commercially, operationally, or technically feasible. The Access Provider reserves the right to reject the Temporary Managed MDS if its duct network and/or civil infrastructure does not extend to the location where the Temporary Managed MDS is requested.
- 3.13. Where the Access Provider agrees to provide a Temporary Managed MDS, the parties agree that such Temporary Managed MDS shall be subject to the charging set out in Schedule 3 (Pricing) for Temporary Managed MDS.
- 3.14. The Access Seeker may request a renewal of the Temporary Managed MDS Service for one or more Temporary Service Period(s) and agrees that such renewal shall be subject to the same charging mechanism as set out in Schedule 3 (Pricing).
- 3.15. The Access Provider may reject a renewal of a Temporary Managed MDS if it considers that such renewal is not commercially, operationally, or technically feasible.
- 3.16. For Managed MDS, the Access Provider shall provide to the Access Seeker a monitoring tool, which shall enable the Access Seeker to monitor the Service against the minimum parameters stipulated below. This monitoring tool shall provide monitoring facilities twenty-four (24) hours a day, seven (7) days a week, three-hundred and sixty-five (365) days a year. The minimum parameters shall include:
- 3.16.1. Link availability; and
 - 3.16.2. Bandwidth utilisation;
- 3.17. For Unmanaged MDS, the Access Seeker acknowledges that the Access Provider shall have no means whatsoever for monitoring the Unmanaged MDS and that the Service is provided on an ‘as-is’ basis. The Access Seeker shall be obliged to report line faults to the Access Provider, and the Access Provider shall respond as noted hereunder.

Amendment to the MDS Service

- 3.18. The Access Seeker shall be entitled to amend a Managed MDS Service in accordance with the specific process set out for amending the MDS in the MDS Operations Manual (Part A for Managed MDS) for the following scenarios:
- 3.18.1. Internal Relocation; and
 - 3.18.2. External Relocation.
- 3.19. The amendments listed in 3.18 above are limited to existing Managed MDS Connections only.
- 3.20. Due to the nature of Unmanaged MDS, the Access Seeker shall not be entitled to seek amendments to any Unmanaged MDS Connection with the exception of External or Internal relocation of a Wireless Radio Site or another end point of the Connection as described in clause 1.1 above. External relocation shall be made at the request of a competent authority. Provided the Access Seeker submits a request in writing, the Access Provider shall facilitate such a relocation and will provide amended Unmanaged MDS to the new location. The Service Period will remain being counted from the Commencement Date of the original Unmanaged MDS Connection before relocation. Charges for relocation as per Schedule 3 (Pricing) shall apply. Any charges will reflect the new distance of the relocated MDS Unmanaged Connection. For avoidance of doubt, relocation involves a change of location of one end point of an existing Unmanaged MDS Connection only (change to both end points will trigger a need for a new Unmanaged MDS Connection). For Internal Relocation, see the Unmanaged MDS Operational Manual.

Access Seeker Obligations

- 3.21. The Access Seeker shall make all necessary arrangements, including but not limited to providing any access or other permissions required to provide MDS Connection to its Core Mobile Site and/or Wireless Radio Site or any other location, as may be required, and arrange for the required site surveys to the abovementioned sites. The Access Provider shall not be held responsible or liable for any failure or a delay in the Access Seeker failing to ascertain the abovementioned permissions or access. Any such delays arising due to any act or omission of the Access Seeker shall suspend any SLAs and/or application of any corresponding Service Level Penalties.
- 3.22. The Access Seeker shall provide the Access Provider with suitable space for, and access during Working Hours (or as may be required to comply with the applicable SLAs, in particular regarding fault restoration) to any Access Provider's Equipment including fiber cables required to be installed or placed in any location in which the MDS is provided within the control of the Access Seeker (or a third party, if and where applicable). If consent is required from a third party, the Access Seeker shall procure such consent free of cost to the Access Provider. The Access Provider is not required to pay the Access Seeker or any third party for the preparation or use of, or access to, space provided pursuant to this clause.
- 3.23. When provisioning a Service Request requiring new Duct build, the Access Provider is responsible for construction of the Duct on public land up until the demarcation point being the boundary of the plot where the Wireless Radio Site (or another site) is located. The Access Seeker is responsible for

construction of the lead-in Duct or in-building Duct or conduit from the demarcation point to the Wireless Radio Site and/or another site including an aggregation Point of Presence.

- 3.24. If the Access Provider's Equipment requires electricity supply and electricity connection points, they shall be supplied, in the location specified by the Access Provider, by the Access Seeker (or any third party for which the Access Seeker shall be responsible) at the Access Seeker's expense according to the equipment specification. Such electricity shall be available at the same level of supply, protection and continuity as that available to the Access Seeker's Equipment.
- 3.25. The Access Seeker shall be solely responsible for any loss, theft, destruction of, or damage (reasonable wear and tear excepted) to the Access Provider's Equipment including any fibre cable required to be installed or placed in the location where the MDS Service is provided, which is within the control of the Access Seeker (or any third party, where the Access Seeker requested the Access Provider to place such Equipment in a location under ownership or control of such third party), occurring anytime and howsoever caused (unless caused by the Access Provider or its agents).
- 3.26. In cases where the overall costs per a Connection exceed fair and reasonable limits, Excess Construction Charges shall be applied as defined in Schedule 3 (Pricing) of the Reference Offer subject to prior agreement between the Access Provider and the Access Seeker or as further described in Schedule 3 (Pricing).
- 3.27. The Access Seeker shall provide the Access Provider and any authorised employee, agent, affiliate or contractor of the Access Provider with all information and assistance that person may reasonably require to design, deliver, test, commission and maintain the MDS Service (which may include, without limitation, participation in testing procedures as and when reasonably requested by the Access Provider).
- 3.28. The Access Seeker may require their agent to be present during the installation, testing or commissioning done by the Access Provider but not so as to affect the Service Commencement Date.
- 3.29. For Unmanaged MDS Connections, the Access Seeker shall arrange at its own cost to allow the Access Provider, or its agents, access to each end point of the Unmanaged MDS Connection at the time of the Access Seeker's installation of the relevant mobile network transmission or similar equipment.

Maintenance and Support

- 3.30. The Access Provider shall provide maintenance and support services in respect of the Managed and Unmanaged MDS Service, respectively, in accordance with Schedule 7 - (Service Levels) of the Reference Offer.
- 3.31. For both MDS Services, the Access Seeker may report a Fault to the Access Provider's nominated contact point which shall be available twenty-four (24) hours per day every day.

Protection

- 3.32. The Access Seeker may procure a full geo-redundant link as protection of the principal MDS Connection. The geo-redundant link is considered as a separate MDS Connection and charged at the applicable MRC as set out in Schedule 3 (Pricing) of the Reference Offer.
- 3.33. The provision of fully geo-redundant link(s) is subject to availability, feasibility study, and subject to the Access Seeker obtaining any relevant approval, including but not limited to access approvals, from the End User, any relevant landlords and/or Government authority.

4. CHARGES

- 4.1. The Access Seeker shall pay to the Access Provider the relevant Charges determined in accordance with Schedule 3 - (Pricing) of this Reference Offer.
- 4.2. All Charges and sums due from one party to the other under this Agreement are exclusive of VAT or any other applicable tax. Any VAT shall be charged in accordance with the relevant regulation in force at the time of making the taxable supply and shall be paid by the paying party following receipt from the billing party of a valid VAT invoice.

5. SERVICE LEVELS

- 5.1. Subject to any limitation set out in this Schedule, the Access Provider shall provide the Managed and Unmanaged MDS Services, respectively, in accordance with the Service Levels specific in Schedule 7 - (Service Levels) of the Reference Offer.

ANNEX 1 - CIRCUIT SPEEDS, DEFINED INTERFACES, MEDIA AND TOPOLOGY

Managed MDS

Service element	Bandwidth	Interface	Connector	Topology	Access
Connection terminating at Wireless Radio Site or Point of Presence	500 Mbps to 10 Gbps	gigabit Ethernet 1000BASE gigabit Ethernet 10GBASE	SC/LC	Ethernet service point-to-point	Fiber
Aggregation Link terminating at the Point of Presence of the Access Seeker	10 Gbps and 100 Gbps	gigabit Ethernet 10GBASE and gigabit Ethernet 100GBASE	SC/LC	Ethernet service point-to-point	Fiber

Unmanaged MDS

Service Element	Connector	Access
Connection terminating at a Wireless Radio Site, Core Mobile Site or a Remote Radio Head site	SC	Fiber
Connection terminating at the BBU or RRH	SC	Fiber
Connection of the CPE	For CPE provided by the Access Seeker – as per Access Seeker's vendor's specifications For CPE provided by the Access Provider – as per Access Provider's vendor specifications	Fiber

ANNEX 2 - TECHNICAL CHARACTERISTICS

Managed MDS

Service Type	Service Attribute	
Ethernet service point-to-point or Ethernet service point-to-multipoint (Pseudowire Ethernet tagged mode with port-based aggregation or virtual aggregation) providing guaranteed symmetrical bandwidth	Interface	Optical Access: 1. GE:1000Base-SX, 1000base –LX. 2. 10GE:10G base –SR, 10G Base LR, 10G Base –ZR,10GE LAN, 10GE WAN.
	Connector	Fibre Access: Single mode LC
	Speed	Please refer to ANNEX 1
	Mode	Duplex
	MAC Layer Supported	Yes
	MAC Address Learning	Yes
	Frame Size	Min 1518, Max 9600 (Jumbo Frame), default 1700
	Class of Service	100% Real-Time. No Over Utilisation
	Maximum Number of CE-VLANs	4096
	Unicast Traffic Limit	Yes
	Multicast Traffic Limit	Yes
	Broadcast Traffic Limit	Yes
	Protocol Treatment	Spanning Tree Protocol (STP), Rapid Spanning Tree Protocol (RSTP), Multiple Spanning Tree Protocol (MSP)
		Pause 802.3
		Link Aggregation Protocol (LACP) (802.1AG),(802.1Q),(802.1D), (802.1P)
	Quality of Service	Round Trip Delay (Frame Transfer Delay): 2ms Jitter (Frame Delay Variations): < 1ms Frame Loss Ratio: 0%

* Frame sizes 64 bytes and 128 bytes are supported by the MDS service but may experience reduced performance.

Customer Premises Equipment (CPE) type:

The Access Provider offers a default CPE for the provision of the Managed MDS Service. The Access Provider may, upon request, include CPE options which are available from alternative vendors. The Access Provider must apply the same Service Levels and reserves the right to vary the CPE from time to time. Only one interface (based on the requirement as referred to in Annex 1) is dedicated as a demarcation interface at Wireless Radio Site for the Managed MDS Service.

Unmanaged MDS Service

Fibre Type	ITU-T Recommendation G.652D
The actual measured attenuation shall be less than or equal to the calculated attenuation for the Unlit Fibre Section under test	<p>“Beginning of Life” (BOL) Calculated Attenuation is $\{(0.35 \times \text{fibre length (Km)}) + (0.06 \times \text{No. of splices}) + (0.5 \times \text{No of connectors})\}$ dB @ 1310nm</p> <p>Calculated Attenuation is $\{(0.25 \times \text{fibre length (Km)}) + (0.06 \times \text{No. of splices}) + (0.5 \times \text{No of connectors})\}$ dB @ 1550nm</p>
End of Life Attenuation per Section	BOL Attenuation + Yrs since RFS x 0.1dB
Average Splice loss	$\leq 0.06\text{dB}$
Maximum individual splice loss	$\leq 0.2\text{dB}$
Chromatic Dispersion*	$\leq 18\text{ps/nm.km @ } 1550\text{nm}$
Maximum individual connector loss	0.5dB
Reflectance of a connector	$< -45\text{dB}$

Unmanaged MDS

Service Type	Service Attribute	
G.652D	Interface	N/A
	Connector	Fibre Access: Single mode LC
	Speed	N/A
	Mode	N/A
	MAC Layer Supported	N/A
	MAC Address Learning	N/A
	Frame Size	N/A
	Class of Service	N/A
	Maximum Number of CE- VLANs	N/A
	Unicast Traffic Limit	N/A
	Multicast Traffic Limit	N/A
	Broadcast Traffic Limit	N/A
	Protocol Treatment	N/A

Core Layer (For information purposes only) – ONLY APPLIES TO MANAGED MDS

- BNET's network enhancement now enables Ethernet VPN (EVPN), allowing the deployment of traffic balancing and flexible deployment on Ethernet.
- The EVPN data is transported through Segment Routing over IPv6 (SRV6) technology on SRV6, ensuring that BNET's core network is able to provide the redundancy and protection required on multiple nodes in a single or multiple (GEO) physical sites.
- As such, this allows BNET to mitigate any single point of failure on its core network by allowing the traffic to be dynamically routed in case of any outage.

ANNEX 3 – PROVISIONING VALIDATION TESTS (AS APPLICABLE)

Provisioning Validation Test	
Testing Methodology	ITU-T Y.1564
Testing Mode	Layer 1-2 Loopback test. Tester simulates CPE
Parameters Tested	Throughput, Frame loss
Tester Speed Setting	MDS-M Service Speed
Tester Frame Size	64, 128, 256, 512, 1024, 1280, 1518 and 9,600 bytes
Acceptance Criteria	Achieved throughput of 95% of MDS-M Service Speed with zero frame loss. Five test iterations of approximately 10 minutes each conducted.
Test Results	Copy provided to the Access Seeker upon request at time of testing

Provisioning Validation Test	
Acceptance Criteria	Link Verification using Optical Time Domain Reflectometry (OTDR)
Test Results	Copy provided to the Access Seeker upon request at time of testing

1. ACCEPTANCE PROCEDURE

- 1.1. Access Provider will prepare the Access Seeker's requirements along the agreed route and perform tests to determine optical performance of the Unmanaged MDS Connection.
- 1.2. The test results will be recorded with the handover form and forwarded to Access Seeker

ANNEX 4 - MDS SERVICE DIAGRAMS

Managed MDS Service between Access Seeker's Core Mobile Site and a Wireless Radio Site

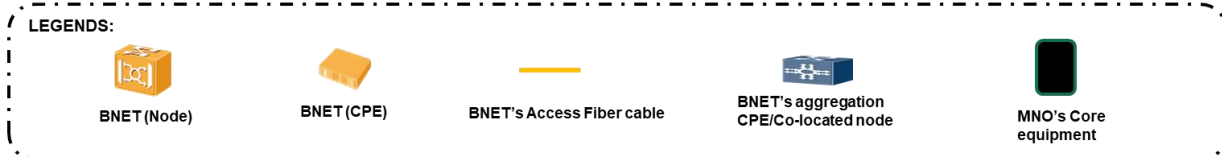
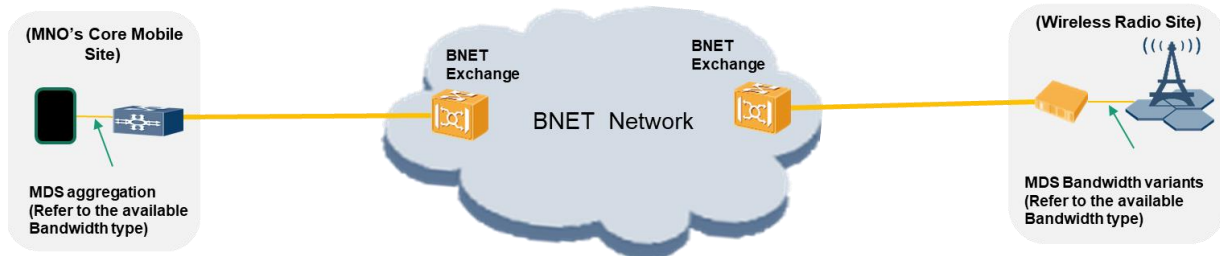

Unmanaged MDS Service between Access Seeker's Core Mobile Site and a Wireless Radio Site to provide end-to-end active service

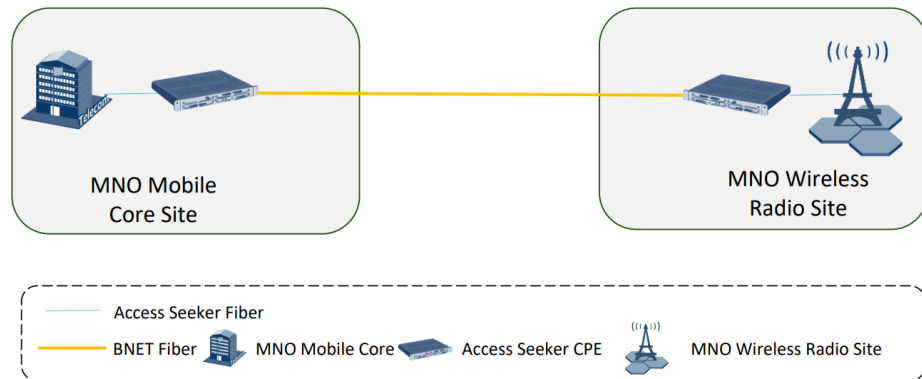

The CPE (Access Seeker CPE) can be provided either by the Access Provider or by the Access Seeker (at the Access Seeker's choice)

Unmanaged MDS Service between Access Seeker's Wireless Radio Site and another Wireless Radio Site to provide end-to-end active service

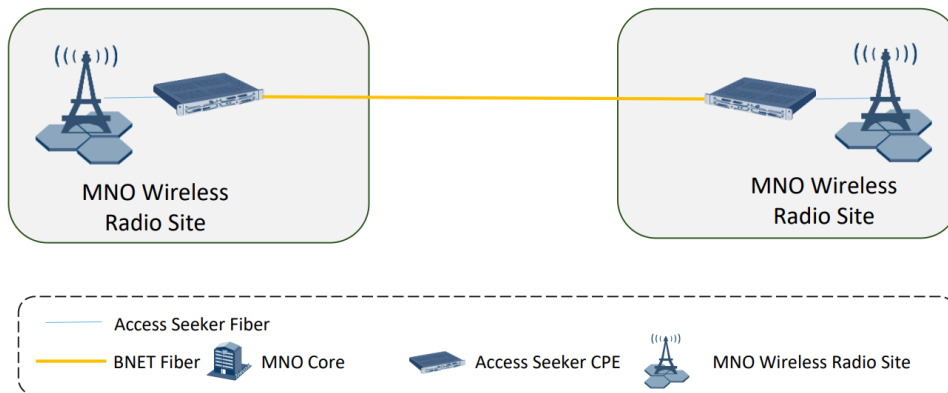

The CPE (Access Seeker CPE) can be provided either by the Access Provider or by the Access Seeker (at the Access Seeker's choice)

Unmanaged MDS Service between a Baseband Unit (BBU) and the corresponding Remote Radio Head (RRH)

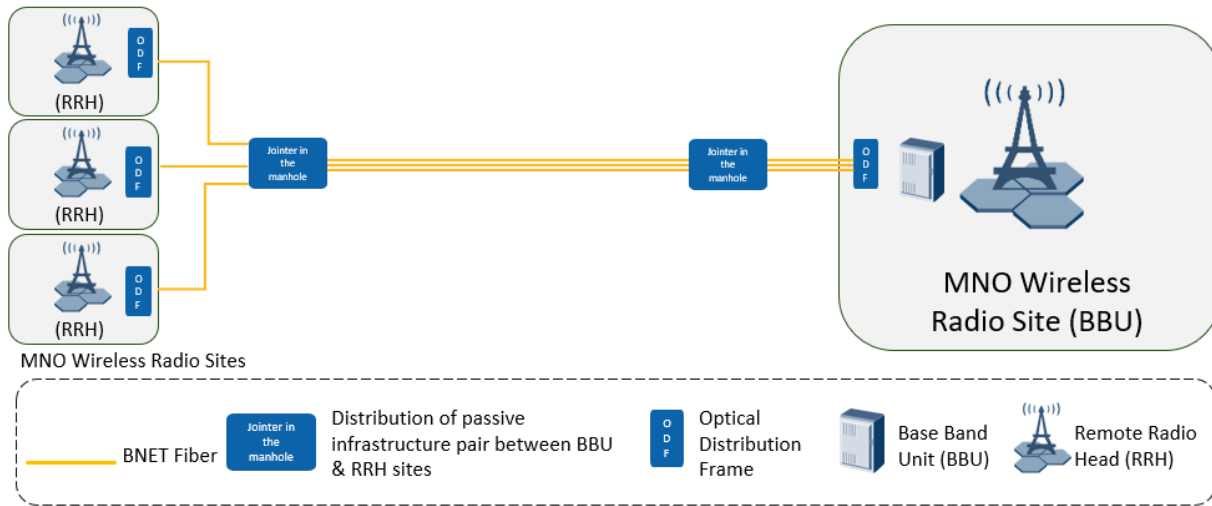

ANNEX 5 TO SCHEDULE 6.3

PART A – Managed MDS (MDS -M) Operations Manual

This document describes the onboarding, provisioning, fulfilment and fault handling process for the Managed MDS (MDS-M) - between the Access Provider and the Access Seeker. This document forms an integral part of the Access Provider's Reference Offer and of Schedule 6.3.

1. Onboarding

1.1 Onboarding Requirements

1.1.1 Access Seeker Onboarding

- (a) The Access Seeker shall review, acknowledge, and sign for Access Provider's counter signature the Supply Terms (Schedule 9) of the Reference Offer.
- (b) The Access Seeker shall have in force and maintain for the term of the Agreement a broad form of public liability insurance to the value of at least BD 250k and property insurance for the assets used in relation to this Agreement to the value of at least BD 100k.
- (c) These policies shall be with a licensed insurance company in the Kingdom of Bahrain and on terms and for coverage limited by only standard industry exclusions or exceptions.

1.1.2 Credit Security

- (a) The Access Seeker shall have in force and maintain security as requested by the Access Provider as required under the Reference Offer Supply Terms.

1.1.3 Licensing and Authorizations

- (a) The Access Seeker shall comply with the terms and conditions set out in the Reference Offer and relevant Service Descriptions, including obtaining any prior authorizations and shall maintain the required licenses as provided for by the Regulator.

1.1.4 Confidentiality and Non-Disclosure

- (a) The Access Seeker is required to execute the Access Provider's Non-Disclosure and Confidentiality Agreement and comply with any data or information protection policies.

1.1.5 BNET BSS

- (a) The Access Provider allows the Access Seeker to integrate via API to the Access Provider's BSS, which is designed based on the telecom standard framework for business process, for placement of Service Order(s) and Service Request(s).
- (b) The Access Provider also provides a graphical User interface portal (the UI or Access Provider Portal) for Access Seeker who do not have the capability to integrate via API. The Access Provider UI is a standard portal that may not provide the same enhanced or benefits that an Access Seeker

would be able to leverage through API integration.

- (c) The Access Provider recommends access via API integration to its BSS.

1.1.6 Process for API Integration

- (a) If the Access Seeker opts for API integration, it shall contact the Access Provider Relationship Manager for API documentation.
- (b) The Access Provider recommends to IT best practices of development and testing on the Access Seekers' Testing Environment and obtaining the relevant acceptances/confirmations from the Access Seekers' internal business units before using the APIs on Production Environment.
- (c) The Access Seeker must inform and align with the Access Provider, with ample amount of time, before using the APIs on production environment.
- (d) The Access Provider does not bear responsibility for actions taken by the Access Seeker on their own through APIs.
- (e) The Access Provider should ensure that all communications with the Access Seeker should be confidential and shall not be disclosed to other Licensed Operators.
- (f) The details of using the API integration to interact with business processes mentioned in this Operational Manual are detailed in the LO API documentation shared by Access Provider.

2 Fulfilment

2.1 Request to Answer

- 2.1.1 The Request to Answer process is a pre-order management process. This process comprises of activities relevant to managing Access Seeker information requests across all communication channels (Access Seeker interfaces).
- 2.1.2 Specific information requests or product requests from the Access Seeker are qualified and addressed.

2.2 MDS-M Availability Check

- 2.2.1 Prior to the Access Seeker placing a Service Order for the relevant Service, it is necessary to check whether the service infrastructure is available. The Access Seeker is provided with the capability to conduct varying levels of pre-qualification checks before submitting a Service Order.
- 2.2.2 In the circumstances where the Access Seeker chooses to submit a Service Order following the pre-qualification checks, the Access Provider shall verify the Service Order through an **Address Availability Check** – to identify whether the Access Seeker Wireless Radio Site or a Core Mobile Site address exists in the Access Provider Address database which depends on the existence of the address in the IGA (Information & eGovernment Authority) address database, subject to BNET being provided such updated information at the time of request.
- 2.2.3 These qualification steps identify whether the Fulfilment request raised by the Access Seeker can be accepted. An Address Availability Check can be performed using the UI and the API integration and are performed by the Access Seeker.

2.3 MDS-M Service Request

- 2.3.1 In the event the Address Availability Check is not successful, the Access Seeker may:
- (a) Where the address is not available on the Access Provider's database, raise a Service Request to add the address to the Access Provider's address database

2.4 Service Requests

- 2.4.1 The Access Provider will, on a monthly basis, update the address list in the Access Provider Database which the Access Seeker shall be privy to if integrated through API or through access of the UI. This information is provided by the IGA.
- 2.4.2 The Access Seeker is required to provide the information requested as per the form and mandatory fields set in the UI/API in order to submit a Service Request. It is important for the Access Seeker to adhere to these mandatory fields, or otherwise may run the risk of having its Service Request rejected.
- 2.4.3 If Access Seeker finds that the address does not exist through the address availability check while raising the Service Order, the Access Seeker shall be eligible to raise a Service Request through the UI or API for an address addition.
- 2.4.4 Every submitted Service Request will be allocated a unique identifier for tracking and managing the Request.
- 2.4.5 As part of the Service Request, the Access Seeker shall input the required information as per the below list, or in accordance with the required fields set out in the UI/API:
- (a) Building number
 - (b) Road Number
 - (c) Block Number
 - (d) Country
- 2.4.6 The Access Seeker is required to attach proof of address documents when raising a Service Request for address addition, such as a valid address card or any documentation which may be deemed as necessary by the IGA authority to validate the Access Seeker's Wireless Radio Site/Point of Presence.
- 2.4.7 The Access Seeker shall be responsible to ensure the validity, authenticity, and completeness of the above-mentioned attachments.
- 2.4.8 Where any of the documentation is considered as invalid, the Service Request shall be reassigned to the Access Seeker for rectification.
- 2.4.9 Where the address is validated by the IGA and accepted, such address will be updated in BNET database and the Service Request shall be closed. Whilst the address may be updated, this does not guarantee that the Service is covered. In this case, the Access Seeker may raise a Service Request for a Cost Assessment (please refer to the process below on a Cost Assessment Service Request).
- 2.4.10 For the avoidance of doubt, if any of the above information requested as inputs from the Access Seeker have not been provided, the Service Levels in Schedule 7 of the Reference Offer will not be applicable.
- 2.4.11 The Access Seeker can issue a pre-order feasibility Service Request, which must contain the Service/product order details along with the requesting address.
- 2.4.12 The Access Seeker must verify the requesting address and the Service/product details (including but not

limited to the Service/Product ID, Service feature requirements, i.e.). These must be included in accordance with the mandatory fields in the Access Provider's UI/API integration.

- 2.4.13 Upon receipt of the Service Request, the Access Provider will assess the Service Access Resources availability at the intended address location and will provide the status of Service provision in accordance with Schedule 7 of the Reference Offer.
- 2.4.14 Service Orders raised subsequent to Service Requests should refer the relevant pre-order feasibility Service Request(s).
- 2.4.15 For the avoidance of doubt, the Access Seeker's Service Request shall be rejected if:
 - (a) it does not specify a valid address; or the address cannot be verified by the authority (IGA); or
 - (b) it does not provide the required inputs delineated above; or
 - (c) it does not have the authorizations provided for by its License to avail of the Service.
- 2.4.16 No service commitment or network resources reservation should be assumed to be done as a result of an unapproved cost assessment Service Request.

2.5 Order to Payment – Fulfilment of Service Orders

- 2.5.1 The Access Seeker may submit a New Connection ("New Provide") Service Order through API integration or via the Access Provider UI/API Integration.
- 2.5.2 The Access Provider will process these Service Orders as described below:
 - (a) Service Orders will only be processed during the Access Provider's Working Hours.
 - (b) The Access Provider will acknowledge receipt of the Service Order within fifteen (15) minutes of receipt of the Service Order
- 2.5.3 A Service Order shall be considered invalid if:
 - (a) it is incomplete or incorrect or illegible or cannot reasonably be understood;
 - (b) it does not properly identify the Wireless Radio Site/Core Mobile Site;
 - (c) it resulted from a processing error.
- 2.5.4 The Access Provider shall, within two (2) Working Days, notify the Access Seeker if the Service Order is accepted or rejected and where applicable, state the required corrections. If a notification is not provided within two (2) Working Days of receipt of the relevant Service Order, the Service Order shall be deemed accepted by the Access Provider.
- 2.5.5 In the event a Service order is rejected then the Access Provider shall provide the Access Seeker with clear reasons for the rejection at the same time of the rejection and identify the changes required to enable the Service order to be accepted.
- 2.5.6 If the Access Seeker submits a Cancellation Request after three (3) or more Working Days from the Notification of Expected RFS Dates and where this is not related to delay in the Date or Actual RFS Date by the Access Provider, the Access Seeker shall (subject to receipt of an appropriate invoice) be liable to pay three (3) MRC to the Access Provider.
- 2.5.7 Within five (5) Working Days from the date of the acceptance of the Service Order, the Access Provider shall notify the RFS Dates to the Access Seeker, as specified in Schedule 7 – (Service Levels) of the Reference Offer. The Access Provider reserves the right to reject the Service Order during this stage if

it is found that the MDS-M Service is not supported or if the Access Provider's point to point Service Access Resources Network does not extend to the requested area within the Kingdom of Bahrain.

- 2.5.8 The Access Seeker shall book service installation initial appointment within 3 working days for service installation once RFS date is notified to Access Seeker. If the Access Provider's technician shall be present at the Wireless Radio Site/ Core Mobile Site to install a MDS-M Service, and if, for any reason, the Access Seeker cannot be available on the Expected RFS Date for such installation, the Access Seeker shall give the Access Provider a minimum written notice of one (1) Working Day. The revised Expected RFS dates are then set following the below principles:
- (a) The Access Seeker shall propose the next earliest date(s) for installation appointment which the Access Provider's technician would be available for the installation which shall be a maximum of three (3) Working Days notice from the day of the missed appointment.
 - (b) The Access Provider shall send the Access Seeker a Notification of revised Expected RFS Date.
- 2.5.9 In addition, if at least one of the following two conditions is met (i) the Access Seeker does not provide the Access Provider a minimum written notice of three (3) Working Days to inform of its unavailability; or (ii) the Access Provider sends a technician who is not able to access the site to install the MDS-M Service, then except for the cases of Force Majeure affecting the Access Seeker, the Access Seeker is liable to pay the installation and configuration charge for the requested MDS-M Service as specified in Schedule 3 - (Pricing) of the Reference Offer. In such case, the modification and Notification of the revised Expected RFS Date and the revised Maximum RFS Date follow the same principles as described in paragraph 2.5.8.
- 2.5.10 Subject to the Access Seeker fulfilling its obligations set out in service description, the Access Provider shall provide, and the Access Seeker shall acquire the MDS-M Service within the standard timescales.
- 2.5.11 Where the Access Provider has accepted a Service order which requires the deployment of Service Access Resources in a particular area, the Access Provider may also seek to recover the costs of such deployment through an NRC.
- 2.5.12 At the time of rejection, the Access Provider shall provide sufficiently detailed written reasons for rejection to the Access Seeker.
- 2.5.13 The SLAs in schedule 7 shall only be applicable to forecasted Service Orders in line with Schedule 5 (Forecasting) of the Reference Offer.
- 2.5.14 A Service Order must be in the format notified by the Access Provider from time to time and be submitted through an online digital interface notified to the Access Seeker by the Access Provider, from time to time.
- 2.5.15 Only in the case where the online digital UI or the API integration setup mechanisms are not accessible, electronic mails shall be accepted as a communication mechanism.
- 2.5.16 The Access Seeker's Billing Account must be active and not in a suspended state in order for the Access Provider to accept and proceed with the Service Order.
- 2.5.17 Access Seeker's Wireless Radio Site/Core Mobile Site permissions & site readiness is the responsibility of Access Seeker to communicate to the Access Provider.

2.5.18 The time slots with regard to appointment rebooking will be made available to the Access Seeker two days from the date of initiating the re-booking of appointment.

Projects

2.5.19 For New Connections of more than fourteen (14) sites, the Access Seeker may request the Access Provider to consider such New Connections as one Project. Subject to agreement between the Access Seeker and Access Provider, the Project will be managed based on an agreed project plan between the Access Provider and Access Seeker.

2.6 Request to Change

2.6.1 To initiate a change to an existing MDS-M Service used by the Access Seeker to supply a service to an End User, the Access Seeker shall provide the Access Provider with a properly completed MDS-M Change Request, in the format notified by the Access Provider from time to time, submitted by electronic mail (or other electronic format, which may include an online digital interface) to the address notified to the Access Seeker by the Access Provider, from time to time.

2.6.2 The Access Provider may, in its sole discretion, elect to accept any MDS-M Change Request notwithstanding that there is any defect in that MDS-M Change Request, if the Access Provider considers that such defect does not have a material effect on the Access Provider's ability to process the MDS-M Change Request and provide the MDS-M Service. Managed MDS Change Request may comprise of any of the following:

- (a) External Relocation
- (b) Internal Relocation
- (c) Upgrade
- (d) Downgrade

2.6.3 The Access Seeker shall submit the request to Access Provider for an internal relocation of the MDS-M Service, which comprises of the relocation of an Access Provider's CPE inside the Wireless Radio Site/Core Mobile Site to another location within the same Wireless Radio Site/Core Mobile Site. The Access Provider shall charge a once off charge in accordance with Schedule 3 – (Pricing) of the Reference Offer for the internal relocation of the existing MDS-M Service.

2.6.4 The Access Seeker shall send the request to the Access Provider for the External Relocation of the MDS-M service, which will follow the same SLA as new connection.

2.6.5 The Access Seeker shall not be liable for any termination or additional recurring charges in respect of a request for Managed MDS Amended Service which is for a relocation. The Access Provider shall charge a once off charge in accordance with Schedule 3 - (Pricing) of the Reference Offer for the relocation unless the Access Seeker requires both Connections to be operational in parallel. The Access Provider shall not terminate the Connection which is subject to relocation until the Service Commencement Date of the new Connection.

- 2.6.6 The Access Seeker shall be entitled to amend a Managed MDS Service by requesting MDS-M Amended Service where this is an Upgrade by providing an Upgrade Request to the Access Provider. The Access Seeker shall only be entitled to Downgrade the throughput of a Connection till the Minimum Service Period has expired. Where the Access Seeker requests a MDS-M Amended Service, then the Service order procedure set out in this Service Description shall apply to that request. Where the Access Seeker requests Managed MDS Amended Service that requires any new Network resources and/or facilities then a new Minimum Service Period shall commence and the Access Provider shall provide a MDS-M Amended Service for the new Service Period.
- 2.6.7 The Access Provider will provide an RFS date with regard to an external relocation that is not within the Forecasted Orders and where the new intended address is not covered by Service Access Resources. For the avoidance of doubt, the SLAs in Schedule 7 will not apply to these Service Orders.
- 2.6.8 For any service upgrade that is not within the Access Seeker's forecasted Service Orders, the SLAs denoted in Schedule 7 will not apply, and the Access Provider shall provide an RFS date based on network capacity availability.

2.7 Exceptions

- 2.7.1 The Access Provider shall, subject to the exceptions, limitations and conditions specified in the Service Description and/or Supply Terms, provision and deliver the MDS-M Service on or before the RFS Date and in accordance with Schedule 7 - (Service Levels) of the Reference Offer.
- 2.7.2 The Parties acknowledge and accept that exceptional circumstances, such as those set out below, may give rise to delays in any stage of the provisioning and delivery of a Service Order. If the occurrence of any of the events below takes place, the Access Provider shall communicate the Exceptional Delivery Date to the Access Seeker and shall not be held liable for the Service Level Penalties. The exceptional circumstances shall only comprise of:
- (a) a Force Majeure Event or a Regulatory Event; or
 - (b) Emergency Maintenance; or
 - (c) any material breach of the Access Seeker's obligations.
 - (d) The Access Provider shall, in notifying the Access Seeker of the Revised Delivery Date, provide sufficient evidence to justify the reasons for the delay of the delivery.
- 2.7.3 The Access Provider shall not be obliged to further process a Service Order where:
- (a) the relevant MDS-M Service cannot meet Service Qualification; or
 - (b) following the provision of reasonable notice by the Access Provider, an authorized person from the End User or the Access Seeker is not available to provide further information when requested.

2.8 Notification of Completion of Order

- 2.8.1 The Access Provider shall, on the same Working Day of completion of a Service Order, notify the Access Seeker of completion.

2.9 Termination to Confirmation

2.9.1 Where the Minimum Service Period has not expired, the Access Seeker shall be entitled to terminate the MDS-A Service on at least one (1) month's written notice to the Access Provider and shall be liable to pay liquidated damages as calculated by the following formula.

2.9.2 Formula for calculating liquidated damages:

$$LD = MRC \times (24 - M)$$

where:

LD = liquidated damages to be paid.

MRC = Monthly Recurring Charge for the MDS-M Service.

M = number of months between the Actual RFS Date and the removal order date rounded-up to the next full month.

2.9.3 The Access Seeker shall not be liable to pay liquidated damages where the Access Seeker terminates the MDS-M Service as a result of and/or arising out of a material breach of the Reference Offer by the Access Provider.

2.9.4 The Access Seeker expressly acknowledges that liquidated damages as calculated above form a reasonable pre-estimate of the loss which the Access Provider would suffer as a result of early termination by the Access Seeker. Such liquidated damages shall be the Access Provider's sole and exclusive damages or monetary remedy for such early termination.

2.9.5 Unless the Access Provider and Access Seeker agree otherwise at the time, any withdrawal or variation of the MDS-M Service, or any amendment to the Charges payable for the MDS-M Service in accordance with this Service Description and Schedule 3 – (Pricing) of the Reference Offer, shall also apply to existing MDS-M Services provided under the Supply Terms, which shall continue in force in accordance with its terms and conditions until renewed or terminated in accordance with this Service Description or the Supply Terms

3 Fault Handling and Resolution

3.1 Faults

3.1.1 The Access Provider's responsibility for faults in the MDS-M Service is limited to the following:

Any faults that affect the MDS-M related to Access Provider's service where such fault is not caused by Access Seekers Network, Systems, Equipment.

3.1.2 The Access Seeker shall be responsible for providing an initial fault diagnosis and reporting for any fault reported to the Access Seeker by its End-Users. The Access Seeker must ensure that its fault reporting service is competent and sufficiently resourced as per the quality standards set in the industry.

3.1.3 Pursuant to paragraph 3.1.2 above and prior to notifying the Access Provider of a fault, the Access Seeker must:

(a) Confirm the presence of a fault;

(b) Perform an initial fault diagnosis to identify where the fault has arisen;

(c) Use all reasonable endeavors to investigate the fault and find out all relevant information from its End-User;

- (d) Confirm that the fault falls under the Access Provider's responsibility with a clear explanation as to why it considers this to be the case.
- 3.1.4 When the Access Seeker has met the conditions set out in paragraph 3.1.3 above, it must report any fault that the Access Provider falls under the Access Provider's responsibility, as set out in paragraph 3.1.1 above, to the Access Provider and provide reasonable information regarding the fault by raised a Customer Problem ticket.
- 3.1.5 If the fault is found to be outside of the Access Provider's responsibility, as set out in paragraph 3.1.1 above, or where the Access Provider cannot confirm the presence of a fault, the Access Provider may charge the Access Seeker on a time and materials basis.

3.2 Fault Resolution

- 3.2.1 The Access Seeker will arrange a site visit that is reasonably required by the Access Provider to clarify the nature of, or undertake work to fix, any Reported Fault.
- 3.2.2 Upon the Access Provider' acknowledgement of a Reported Fault that is the Access Provider' responsibility, the Access Provider will:
 - (a) diagnose and fix the Reported Fault;
 - (b) following the initial diagnosis, provide an indication to the Access Seeker of the likely time to fix the Reported Fault (Response, provided that the Access Provider has no obligation to provide such indication if the Reported Fault is fixed at the time of initial diagnosis.

3.3 Reporting Faults to the Access Provider

- 3.3.1 The Access Provider has two automated channels which allows the Access Seeker to create customer trouble tickets:
 - (a) UI
 - (b) API Integration
- 3.3.2 The two channels allow Access Seekers to:
 - (a) create a new Service Assurance Ticket;
 - (b) retrieve status and updates on a trouble ticket; and
 - (c) Receive ticket resolution and closure updated along with root cause.
- 3.3.3 Faults can be logged 24 hours a day, seven days a week.
- 3.3.4 The Access Seeker must use the Access Provider UI or API Integration for reporting all faults regarding the MDS-M Service. If the Access Seeker uses any other method to report a fault, the fault will not be acknowledged by the Access Provider or attended and the Service Levels as defined will not apply to that fault.
- 3.3.5 Where the Access Provider advises the Access Seeker that UI /API is unavailable, the Access Seeker must submit fault reports to the Access Provider by calling the Access Provider. The Access Provider will use all reasonable endeavors to advise Access Seekers immediately upon becoming aware that the UI /API is unavailable.

- 3.3.6 Once the Access Seeker has provided initial fault diagnosis, determined that it requires the Access Provider assistance to resolve the fault, the following information is required when reporting a fault:
- (a) confirmation that the initial fault diagnosis has been completed;
 - (b) contact name and phone number of the Access Seeker staff member logging the fault;
 - (c) fault type and description;
 - (d) time the fault occurred;
 - (e) address and contact details for the site of the fault (where appropriate); and
 - (f) any other relevant information.
- 3.3.7 If any of the above information set out from (a) to (f) in paragraph 3.3.6 above is not provided, the Service Levels in the Schedule 7 of the Access Provider Reference Offer will not apply.

3.4 Fault Report Acknowledgement

- 3.4.1 When a fault report is received, the Access Provider will advise the Access Seeker, acknowledging receipt of the fault report within specified SLA in schedule 7.

3.5 Fault Tracking

- 3.5.1 All faults will be logged in UI /API integration and the Access Seeker will be given a fault reference number where the access seeker can get the update on the raised trouble tickets and the progress to restore the service.
- 3.5.2 Where the Access Provider subsequently becomes apparent that the fault restoration time cannot be met, the Access Provider will advise the Access Seeker of a revised fault restoration time.

3.6 Access Seeker Site Premises Visit

- 3.6.1 If the Access Provider identifies the need to send a field engineer to the Access Seeker site, the Access Provider will update Access Seeker trouble ticket in UI/API integration.
- 3.6.2 The Access Seeker's is responsible for coordinating site access, visit appointment and any required outage window with any relevant landlord.
- 3.6.3 In case the Access Seeker does not respond to the Access Provider calls to confirm appointment, the KPI will be stopped and access seeker will need to re-book appointment and inform the Access Provider with new appointment booked.

3.7 Fault Types

- 3.7.1 If the issue can be fixed remotely, the Access Provider will fix the issue and the Service Assurance Ticket will be updated accordingly.
- 3.7.2 In the event where the issue is within passive or active resources, a planned outage will be required and the Access Provider will inform the access seeker on planning outage timings.
- 3.7.3 Access Seeker representatives to be available at the time of the visit to verify and accept the resolution.

3.8 Fault Closure

- 3.8.1 Once the fault has been resolved, the Access Provider will notify the Access Seeker via UI/API integration that the fault has been resolved, confirm the reference number and, where possible, provide the cause of the fault and any actions taken to reach resolution.

3.9 Emergency and Core Network Faults

- 3.9.1 Emergency and Core Network faults reported to the Access Provider will be treated on a case-by-case basis. In the first instance, the Access Provider will propose a temporary solution. However, in the absence of a viable temporary solution, the Access Provider may schedule a callout to respond to Core Network faults, or to emergency faults relating to mass outage that impacts an entire block or area.

4 Complaints

- 4.1 This section deals with Access Seeker enquiries where the Access Seeker is not satisfied with a product and/or handling and timeliness of an enquiry.

- 4.1.1 Access Seekers can reach their designated account manager to report any complaint related to non-technical issues.

4.2 The Access Provider Network, the Access Provider Owned Equipment and Property.

- 4.2.1 For the Access Seeker's own safety, and so that services supplied by the Access Provider are not disrupted, the Access Seeker must help safeguard the Access Provider' Network and the Access Provider Owned Equipment. The Access Seeker must:

- (a) Follow the Access Provider' reasonable directions when connecting anything to the Access Provider' Network or any the Access Provider Owned Equipment
- (b) Only allow people authorised by the Access Provider to work on or around the Access Provider' Network or the Access Provider Owned Equipment; and
- (c) make sure everyone the Access Seeker is responsible for also meets these obligations.

4.3 Access Seeker Responsibility towards the Access Provider Owned Equipment

- 4.3.1 At the time any of the Access Provider Owned Equipment is supplied, the Access Provider will use all reasonable endeavors to make sure it is safe, durable and approved for connection to the rest of the Access Provider' Network.

- 4.3.2 Where the Access Provider supplies the Access Seeker with any the Access Provider Owned Equipment, the Access Seeker will, where applicable:

- (a) leave the Access Provider Owned Equipment installed and not use it otherwise than in specified in the service description.
- (b) protect the Access Provider Owned Equipment from radio or electrical interference, power fluctuations, abnormal environmental conditions, theft and any other risks of loss or damage.
- (c) if the Access Provider Owned Equipment is lost, stolen or damaged, notify the Access Provider directly and pay for repairing or replacing it, except where the loss, theft or damage was caused by

- the Access Provider;
 - (d) follow the Access Provider' reasonable directions when using the Access Provider Owned Equipment and never use the Access Provider Owned Equipment for purposes for which it is not designed; and
 - (e) not encumber the Access Provider' title to the Access Provider Owned Equipment or expose such title to third Party claims and notify the Access Provider if it becomes aware of any third-Party claim.
- 4.3.3 When any the Access Provider Owned Equipment is no longer required the Access Seeker:
- (a) must return the Access Provider Owned Equipment to the Access Provider;
 - (b) will take reasonable care to avoid causing damage when returning the Access Provider Owned Equipment to the Access Provider and be responsible for any damage to the Access Provider Owned Equipment; and
 - (c) must pay all Charges for the Access Provider Owned Equipment until such time as it is returned to the Access Provider.

5 Planned Outages and Maintenance

5.1 General Obligations

- 5.1.1 The Access Provider may suspend any MDS-M in order to carry out Planned or Emergency Maintenance.
- 5.1.2 In the case of Planned Maintenance, the Access Provider shall use its best endeavors to carry such activity during the night or at weekends or other quiet periods.
- 5.1.3 The Access Provider shall give ten (10) Working Days' notice of each Planned Maintenance activity affecting a particular MDS-M Service or group of MDS-M Services. This shall include the circuits affected, the date and time of the suspension and the likely duration of the suspension.
- 5.1.4 The Access Provider shall give three (3) Days' notice of each Emergency Maintenance activity affecting a particular MDS-M Service or group of MDS-M Services. This shall include the circuits affected, the date and time of the suspension and the likely duration of the suspension.
- 5.1.5 In cases of Emergency Maintenance, the Access Provider shall advise the Access Seeker within five (5) hours after service is restored with a report of the cause of the Fault.
- 5.1.6 The Access Provider shall use its reasonable endeavors to take into account the reasonable operational concerns of the Access Seeker before implementing any Planned Maintenance.

5.2 Types of maintenance and support services

- 5.2.1 The Access Provider shall provide Network maintenance and support services, such as CPE replacement and Service Access Resources patch cord replacement, in accordance with the Service Levels set out in Schedule 7 - (Service Levels) of the Reference Offer. In the event that such replacement is required due to Access Seeker or End User misuse, the Access Provider reserves the right to re-charge the replacement cost of these equipment(s) to the Access Seeker.

ANNEX 5 TO SCHEDULE 6.3

PART B - Unmanaged MDS (MDS-U) Operations Manual

This document describes the onboarding, provisioning, fulfilment and fault handling process for the Unmanaged MDS (MDS-U) between the Access Provider and the Access Seeker. This document forms an integral part of the Access Provider's Reference Offer and of Schedule 6.3.

1. Onboarding

1.1.1 Onboarding Requirements

1.1.2 Access Seeker Onboarding

- (a) The Access Seeker shall review, acknowledge, and sign for Access Provider's counter signature the Supply Terms (Schedule 9) of the Reference Offer.
- (b) The Access Seeker shall have in force and maintain for the term of the Agreement a broad form of public liability insurance to the value of at least BD 250k and property insurance for the assets used in relation to this Agreement to the value of at least BD 100k.
- (c) These policies shall be with a licensed insurance company in the Kingdom of Bahrain and on terms and for coverage limited by only standard industry exclusions or exceptions.

1.1.3 Credit Security

- (a) The Access Seeker shall have in force and maintain security as requested by the Access Provider as required under the Reference Offer Supply Terms.

1.1.4 Licensing and Authorizations

- (a) The Access Seeker shall comply with the terms and conditions set out in the Reference Offer and relevant Service Descriptions, including obtaining any prior authorizations and shall maintain the required licenses as provided for by the Regulator.

1.1.5 Confidentiality and Non-Disclosure

- (a) The Access Seeker is required to execute the Access Provider's Non-Disclosure and Confidentiality Agreement and comply with any data or information protection policies.

1.1.6 BNET BSS

- (a) The Access Provider allows the Access Seeker to integrate via API to the Access Provider's BSS, which is designed based on the telecom standard framework for business process, for placement of Service Order(s) and Service Request(s).
- (b) The Access Provider also provides a graphical User Interface portal (the UI or Access Provider Portal) for Access Seeker who do not have the capability to integrate via API. The Access Provider UI is a standard portal that may not provide the same enhanced features or benefits that an Access

Seeker would be able to leverage through API integration.

- (c) The Access Provider recommends access via API integration to its BSS.

1.1.7 Process for API Integration

- (a) If the Access Seeker opts for API integration, it shall contact the Access Provider Relationship Manager for API documentation.
- (b) The Access Provider recommends to IT best practices of development and testing on the Access Seekers' Testing Environment and obtaining the relevant acceptances/confirmations from the Access Seekers' internal business units before using the APIs on Production Environment.
- (c) The Access Seeker must inform and align with the Access Provider, with ample amount of time, before using the APIs on production environment.
- (d) The Access Provider does not bear responsibility for actions taken by the Access Seeker on their own through APIs.
- (e) The Access Provider should ensure that all communications with the Access Seeker should be confidential and shall not be disclosed to other Licensed Operators.
- (f) The details of using the API integration to interact with business processes mentioned in this Operational Manual are detailed in the LO API documentation shared by Access Provider.

2 Fulfillment

2.1 Request to Answer

- 2.1.1 The Request to Answer process is a pre-order management process. This process comprises of activities relevant to managing Access Seeker information requests across all communication channels (Access Seeker interfaces).
- 2.1.2 Specific information requests or product requests from the Access Seeker are qualified and addressed.

2.2 MDS-U Availability Check

- 2.2.1 Prior to the Access Seeker placing a Service Order for the relevant Service, it is necessary to check whether the service infrastructure is available. The Access Seeker is provided with the capability to conduct varying levels of pre-qualification checks before submitting a Service Order.
- 2.2.2 In the circumstances where the Access Seeker chooses to submit a Service Order following the pre-qualification checks, the Access Provider shall verify the Service Order through an **Address Availability Check** – to identify whether the Access Seeker Wireless Radio Site, Core Mobile Site or the Remote Radio Head site address exists in the Access Provider Address database, which depends on the existence of the address in the IGA (Information & eGovernment Authority) address database, subject to BNET being provided such updated information at the time of request.
- 2.2.3 These qualification steps identify whether the Fulfilment request raised by the Access Seeker can be accepted. An Address Availability Check can be performed using the UI and the API integration and are performed by the Access Seeker.

2.3 MDS-U Service Request

2.3.1 In the event the address availability check is not successful, the Access Seeker may:

- (a) Where the address is not available on the Access Provider's database, raise a Service Request to add the address to the Access Provider's address database.

2.4 Service Requests

2.4.1 The Access Provider will, on a monthly basis, update the address list in the Access Provider Database which the Access Seeker shall be privy to if integrated through API or through access of the UI. This information is provided by the IGA.

2.4.2 The Access Seeker is required to provide the information requested as per the form and mandatory fields set in the UI/API in order to submit a Service Request. It is important for the Access Seeker to adhere to these mandatory fields, or otherwise may run the risk of having its Service Request rejected.

2.4.3 If Access Seeker finds that the address does not exist through the address availability check while raising the Service Order, the Access Seeker shall be eligible to raise a Service Request through the UI or API for an address addition.

2.4.4 Every submitted Service Request will be allocated a unique identifier for tracking and managing the Request.

2.4.5 As part of the Service Request, the Access Seeker shall input the required information as per the below list, or in accordance with the required fields set out in the UI /API:

- (a) Building Character
- (b) Building Number
- (c) Road Number
- (d) Block Number
- (e) Country

2.4.6 The Access Seeker is required to attach proof of address documents when raising a Service Request for address addition, such as a valid address card or any documentation which may be deemed as necessary by the IGA authority to validate the Access Seeker's Wireless Radio Site.

2.4.7 The Access Seeker shall be responsible to ensure the validity, authenticity, and completeness of the above-mentioned attachments.

2.4.8 Where any of the documentation is considered as invalid, the Service Request shall be reassigned to the Access Seeker for rectification.

2.4.9 Where the address is validated by the IGA and accepted, such address will be updated in BNET database and the Service Request shall be closed. Whilst the address may be updated, this does not guarantee that the Service is covered. In this case, the Access Seeker may raise a Service Request for a Cost Assessment (please refer to the process below on a Cost Assessment Service Request).

2.4.10 For the avoidance of doubt, if any of the above information requested as inputs from the Access Seeker have not been provided, the Service Levels in Schedule 7 of the Reference Offer will not be applicable.

2.4.11 The Access Seeker can issue a pre-order feasibility Service Request, which must contain the Service/product order details along with the requesting address.

- 2.4.12 The Access Seeker must verify the requesting address and the Service/product details (including but not limited to the Service/Product ID, Service feature requirements). These must be included in accordance with the mandatory fields in the Access Provider's UI/API integration.
- 2.4.13 Upon receipt of the Service Request, the Access Provider will assess the Service Access Resources availability at the intended address location and will provide the status of Service provision in accordance with Schedule 7 of the Reference Offer.
- 2.4.14 Service Orders raised subsequent to Service Requests should refer the relevant pre-order feasibility Service Request(s).
- 2.4.15 For the avoidance of doubt, the Access Seeker's Service Request shall be rejected if:
 - (a) it does not specify a valid address; or the address cannot be verified by the authority (IGA); or
 - (b) it does not provide the required inputs delineated above; or
 - (c) it does not have the authorizations provided for by its License to avail of the Service.
- 2.4.16 No service commitment or network resources reservation should be assumed to be done as a result of an unapproved cost assessment Service Request.

2.5 Order to Payment – Fulfilment of Service Orders

- 2.5.1 The Access Seeker may submit a New Connection ("New Provide") Service Order through API integration or via the Access Provider UI/API Integration.
- 2.5.2 The Access Provider will process these Service Orders as described below:
 - (a) Service Orders will only be processed during the Access Provider's Working Hours.
 - (b) The Access Provider will acknowledge receipt of the Service Order within fifteen (15) minutes of receipt of the Service Order
- 2.5.3 A Service Order shall be considered invalid if:
 - (a) it is incomplete or incorrect or illegible or cannot reasonably be understood;
 - (b) it does not properly identify the Wireless Radio Site, Core Mobile Site or a Remote Radio Head site;
 - (c) it resulted from a processing error.
- 2.5.4 The Access Provider shall, within five (5) Working Days, notify the Access Seeker if the Service Order is accepted or rejected and where applicable, state the required corrections.
- 2.5.5 Within thirty (30) Working Days from the date of the acceptance of the Service Order, the Access Provider shall provide the solution design based on the requirement with the expected RFS Dates to the Access Seeker, as specified in Schedule 7 – (Service Levels) of the Reference Offer. The Access Provider reserves the right to reject the Service Order during this stage if it is found that the MDS-U Service is not supported or if the Access Provider's point to point Service Access Resources Network does not extend to the requested area within the Kingdom of Bahrain.
- 2.5.6 The Access Seeker shall, within fifteen (15) Working Days confirm on the acceptance of the provided solution by The Access Provider.
- 2.5.7 The Access Seeker shall book service installation initial appointment within 3 working days for service installation once RFS date is notified to Access Seeker as described in the service description, to allow Access Provider to be present when the Access seeker connect to the relevant mobile network

equipment to the particular Connection, and before the Commencement to Date to verify compliance with service description. Access Provider's technician shall be present at Wireless Radio Site, Core Mobile Site or a Remote Radio Head site to install a MDS-U Service, and if, for any reason, the Access Seeker cannot be available on the Expected RFS Date for such installation, the Access Seeker shall give the Access Provider a minimum written notice of one (1) Working Day. The revised Expected RFS dates are then set following the below principles.

(a) The Access Seeker shall propose the next earliest date(s) for installation appointment which the Access Provider's technician would be available for the installation which shall be a maximum of three (3) Working Days notice from the day of the missed appointment.

(b) The Access Provider shall send the Access Seeker a Notification of revised Expected RFS Date.

2.5.8 In addition, if at least one of the following two conditions is met (i) the Access Seeker does not provide the Access Provider a minimum written notice of three (3) Working Days to inform of its unavailability; or (ii) the Access Provider sends a technician who is not able to access the site to install the MDS-U Service, then except for the cases of Force Majeure affecting the Access Seeker, the Access Seeker is liable to pay the installation charge for the requested MDS-U Service as specified in Schedule 3 - (Pricing) of the Reference Offer. In such case, the modification and Notification of the revised Expected RFS Date and the revised Maximum RFS Date follow the same principles as described in paragraph 2.5.8.

2.5.9 Subject to the Access Seeker fulfilling its obligations set out in service description, the Access Provider shall provide, and the Access Seeker shall acquire the MDS-U Service within the agreed timescales.

2.5.10 Subject to any other agreed arrangement between the Access Provider and the Access Seeker for the installation of MDS-U, the Access Provider (including its approved contractor) shall arrange for the installation and supply of the Fibre and shall install such Fiber to the Core Mobile Site, Wireless Radio Site or a Remote Radio Head site RRH. The Access Provider shall prepare a quotation for the supply of the fibre material and the installation works for the fiber route until the demarcation points (as explained in the clause below) using the rates for time and material as set out in Schedule 3 (Pricing) - Annex 1. The Access Provider shall provide this quotation to the Access Seeker and following the Access Seeker's approval, shall conduct the works.

2.5.11 The Access Provider shall be responsible for any duct built and for deploying Fibre Cable to the demarcation point of the Core Mobile Site, Wireless Radio Site or a Remote Radio Head site. The Access Provider shall not be responsible for any ducting inside customer premises. The Access Seeker shall meet the costs of all such installation works in accordance with the provisions of Schedule 3 - (Pricing) of the Reference Offer.

2.5.12 The provision of the MDS-U Service is subject to availability of space, capacity and related Facilities.

2.5.13 At the time of rejection, the Access Provider shall provide sufficiently detailed written reasons for rejection to the Access Seeker.

2.5.14 The SLAs in schedule 7 shall only be applicable to forecasted Service Orders in line with Schedule 5 (Forecasting) of the Reference Offer.

- 2.5.15 A Service Order must be in the format notified by the Access Provider from time to time and be submitted through an online digital interface notified to the Access Seeker by the Access Provider, from time to time.
- 2.5.16 Only in the case where the online digital UI or the API integration setup mechanisms are not accessible, electronic mails shall be accepted as a communication mechanism.
- 2.5.17 The Access Seeker's Billing Account must be active and not in a suspended state in order for the Access Provider to accept and proceed with the Service Order.
- 2.5.18 Access Seeker's Core Mobile Site Wireless Radio Site or a Remote Radio Head site permissions & site readiness is the responsibility of Access Seeker to communicate to the Access Provider.
- 2.5.19 The time slots with regard to appointment rebooking will be made available to the Access Seeker two days from the date of initiating the re-booking of appointment.

Projects

- 2.5.20 For New Connections of more than fourteen (14) sites, the Access Seeker may request the Access Provider to consider such New Connections as one Project. Subject to agreement between the Access Seeker and Access Provider, the Project will be managed based on an agreed project plan between the Access Provider and Access Seeker.

2.6 Request to Change

- 2.6.1 To initiate a change to an existing MDS-U Service used by the Access Seeker, the Access Seeker shall provide the Access Provider with a properly completed MDS-U Change Request, in the format notified by the Access Provider from time to time, submitted by electronic mail (or other electronic format, which may include an online digital interface) to the address notified to the Access Seeker by the Access Provider, from time to time.
- 2.6.2 The Access Provider may, in its sole discretion, elect to accept any MDS-U Change Request notwithstanding that there is any defect in that MDS-U Change Request, if the Access Provider considers that such defect does not have a material effect on the Access Provider's ability to process the MDS-U Change Request and provide the MDS-U Service. A MDS-U Change Request may comprise of any of the following:
 - (a) External Relocation
 - (b) Internal Relocation
- 2.6.3 The Access Seeker shall submit the request to Access Provider for an internal relocation of the MDS-U Service, which comprises of the relocation of an Access Provider's ODF/Patch Panel inside the Core Mobile Site, Wireless Radio Site or a Remote Radio Head site to another location within the same Core Mobile Site, Wireless Radio Site or a Remote Radio Head site. The Access Provider shall charge a once off charge in accordance with Schedule 3 – (Pricing) of the Reference Offer for the internal relocation of the existing MDS-U Service.
- 2.6.4 The Access Seeker shall send the request to the Access Provider for the external relocation of the MDS-U service, which will follow the same process of SLA criteria as new connection.

- 2.6.5 The Access Seeker shall not be liable for any termination or additional recurring charges in respect of a request for a MDS-U Amended Service which is for a relocation. The Access Provider shall charge a once off charge in accordance with Schedule 3 - (Pricing) of the Reference Offer for the relocation. In the case where the Access Seeker requires both Connections to be operational in parallel, the Access Provider shall not terminate the Connection which is subject to relocation until the Service Commencement Date of the new Connection.
- 2.6.6 The Access Provider will provide an RFS date regarding an external relocation that is not within the Forecasted Orders and where the new intended address is not covered by Service Access Resources. For the avoidance of doubt, the SLAs in Schedule 7 will not apply to these Service Orders.

2.7 Exceptions

- 2.7.1 The Access Provider shall, subject to the exceptions, limitations and conditions specified in the Service Description and/or Supply Terms, provision and deliver the MDS-U Service on or before the RFS Date and in accordance with Schedule 7 - (Service Levels) of the Reference Offer.
- 2.7.2 The Parties acknowledge and accept that exceptional circumstances, such as those set out below, may give rise to delays in any stage of the provisioning and delivery of a Service Order. If the occurrence of any of the events below takes place, the Access Provider shall communicate the Exceptional Delivery Date to the Access Seeker and shall not be held liable for the Service Level Penalties. The exceptional circumstances shall only comprise of:
- (a) a Force Majeure Event or a Regulatory Event; or
 - (b) Emergency Maintenance; or
 - (c) any material breach of the Access Seeker's obligations.
 - (d) The Access Provider shall, in notifying the Access Seeker of the Revised Delivery Date, provide sufficient evidence to justify the reasons for the delay of the delivery.
- 2.7.3 The Access Provider shall not be obliged to further process a Service Order where:
- (a) the relevant MDS-U Service cannot meet Service Qualification; or
 - (b) following the provision of reasonable notice by the Access Provider, an authorized person from the Access Seeker is not available to provide further information when requested.

2.8 Notification of Completion of Order

- 2.8.1 The Access Provider shall, on the same Working Day of completion of a Service Order, notify the Access Seeker of completion.

2.9 Termination to Confirmation

- 2.9.1 Where the Minimum Service Period has not expired, the Access Seeker shall be entitled to terminate the MDS-U Service on at least one (1) month's written notice to the Access Provider and shall be liable to pay liquidated damages as calculated by the following formula.

2.9.2 Formula for calculating liquidated damages:

$$LD = MRC \times (24-M)$$

where:

LD = liquidated damages to be paid.

MRC = Monthly Recurring Charge for the MDS-U Service.

M = number of months between the Actual RFS Date and the removal order date rounded-up to the next full month.

2.9.3 The Access Seeker shall not be liable to pay liquidated damages where the Access Seeker terminates the MDS-U Service as a result of and/or arising out of a material breach of the Reference Offer by the Access Provider.

2.9.4 The Access Seeker expressly acknowledges that liquidated damages as calculated above form a reasonable pre-estimate of the loss which the Access Provider would suffer as a result of early termination by the Access Seeker. Such liquidated damages shall be the Access Provider's sole and exclusive damages or monetary remedy for such early termination.

2.9.5 Unless the Access Provider and Access Seeker agree otherwise at the time, any withdrawal or variation of the MDS-U Service, or any amendment to the Charges payable for the MDS-U Service in accordance with this Service Description and Schedule 3 – (Pricing) of the Reference Offer, shall also apply to existing MDS-U Services provided under the Supply Terms, which shall continue in force in accordance with its terms and conditions until renewed or terminated in accordance with this Service Description or the Supply Terms

3 *Fault Handling and Resolution*

3.1 *Faults*

3.1.1 The Access Provider's responsibility for faults in the MDS-U Service is limited to the following:

Any faults that affect the MDS-U related to Access Provider's fiber infrastructure where such fault is not caused by Access Seekers Network, Systems, Equipment.

3.1.2 The Access Seeker shall be responsible for providing an initial fault diagnosis and reporting for any fault reported to the Access Seeker by its End-Users. The Access Seeker must ensure that its fault reporting service is competent and sufficiently resourced as per the quality standards set in the industry.

3.1.3 Pursuant to paragraph 3.1.2 above and prior to notifying the Access Provider of a fault, the Access Seeker must:

- (a) Confirm the presence of a fault;
- (b) Perform an initial fault diagnosis to identify where the fault has arisen;
- (c) Use all reasonable endeavors to investigate the fault and find out all relevant information from its End-User;
- (d) Confirm that the fault falls under the Access Provider's responsibility with a clear explanation as to why it considers this to be the case.

- 3.1.4 When the Access Seeker has met the conditions set out in paragraph 3.1.33 above, it must report any fault that the Access Provider falls under the Access Provider's responsibility, as set out in paragraph 3.1.1 above, to the Access Provider and provide reasonable information regarding the fault by raised a Customer Problem ticket.
- 3.1.5 If the fault is found to be outside of the Access Provider's responsibility, as set out in paragraph 3.1.1 above, or where the Access Provider cannot confirm the presence of a fault, the Access Provider may charge the Access Seeker on a time and materials basis.

3.2 Fault Resolution

- 3.2.1 The Access Seeker will arrange a site visit. This is reasonably required by the Access Provider to clarify the nature of, or undertake work to fix, any Reported Fault.
- 3.2.2 Upon the Access Provider' acknowledgement of a Reported Fault that is the Access Provider' responsibility, the Access Provider will:
 - (a) diagnose and fix the Reported Fault;
 - (b) following the initial diagnosis, provide an indication to the Access Seeker of the likely time to fix the Reported Fault (Response, provided that the Access Provider has no obligation to provide such indication if the Reported Fault is fixed at the time of initial diagnosis.

3.3 Reporting Faults to the Access Provider

- 3.3.1 The Access Provider has two automated channels which allows the Access Seeker to create customer trouble tickets:
 - (a) UI
 - (b) API Integration
- 3.3.2 The two channels allow Access Seekers to:
 - (a) create a new Service Assurance Ticket;
 - (b) retrieve status and updates on a trouble ticket; and
 - (c) Receive ticket resolution and closure updated along with root cause.
- 3.3.3 Faults can be logged 24 hours a day, seven days a week.
- 3.3.4 The Access Seeker must use the Access Provider UI or API Integration for reporting all faults regarding the MDS-U Service. If the Access Seeker uses any other method to report a fault, the fault will not be acknowledged by the Access Provider or attended and the Service Levels as defined will not apply to that fault.
- 3.3.5 Where the Access Provider advises the Access Seeker that UI /API is unavailable, the Access Seeker must submit fault reports to the Access Provider by calling the Access Provider. The Access Provider will use all reasonable endeavors to advise Access Seekers immediately upon becoming aware that the UI /API is unavailable.

- 3.3.6 Once the Access Seeker has provided initial fault diagnosis, determined that it requires the Access Provider assistance to resolve the fault, the following information is required when reporting a fault:
- (a) confirmation that the initial fault diagnosis has been completed;
 - (b) contact name and phone number of the Access Seeker staff member logging the fault;
 - (c) fault type and description;
 - (d) time the fault occurred;
 - (e) address and contact details for the site of the fault (where appropriate); and
 - (f) any other relevant information.
- 3.3.7 If any of the above information set out from (a) to (f) in paragraph 3.3.6 above is not provided, the Service Levels in the Schedule 7 of the Access Provider Reference Offer will not apply.

3.4 Fault Report Acknowledgement

- 3.4.1 When a fault report is received, the Access Provider will advise the Access Seeker, acknowledging receipt of the fault report within specified SLA in schedule 7.

3.5 Fault Tracking

- 3.5.1 All faults will be logged in UI /API integration and the Access Seeker will be given a fault reference number where the access seeker can get the update on the raised trouble tickets and the progress to restore the service.
- 3.5.2 Where the Access Provider subsequently becomes apparent that the fault restoration time cannot be met, the Access Provider will advise the Access Seeker of a revised fault restoration time.

3.6 Access Seeker Site Premises Visit

- 3.6.1 If the Access Provider identifies the need to send a field engineer, the Access Provider will update Access Seeker trouble ticket in UI/API integration.
- 3.6.2 The Access Seeker's is responsible for coordinating site access, visit appointment and any required outage window with the relevant landlord.
- 3.6.3 In case the Access Seeker does not respond to the Access Provider calls to confirm appointment, the KPI will be stopped and access seeker will need to re-book appointment and inform the Access Provider with new appointment booked.

3.7 Fault Types

- 3.7.1 If the issue can be fixed remotely, the Access Provider will fix the issue and the Service Assurance Ticket will be updated accordingly.
- 3.7.2 Where applicable to fix a Fault, a planned outage will be required and the Access Provider will inform the access seeker on planning outage timings.
- 3.7.3 Access Seeker representative to be available at the time of the visit to verify and accept the resolution.

3.8 Fault Closure

- 3.8.1 Once the fault has been resolved, the Access Provider will notify the Access Seeker via UI/API integration that the fault has been resolved, confirm the reference number and, where possible, provide the cause of the fault and any actions taken to reach resolution.

3.9 Emergency and Core Network Faults

- 3.9.1 Emergency faults reported to the Access Provider will be treated on a case-by-case basis. In the first instance, the Access Provider will propose a temporary solution. However, in the absence of a viable temporary solution, the Access Provider may schedule a callout to respond to faults, or to emergency faults relating to mass outage that impacts an entire block or area.

4 Complaints

- 4.1 This section deals with Access Seeker enquiries where the Access Seeker is not satisfied with a product and/or handling and timeliness of an enquiry.

- 4.1.1 Access Seekers can reach their designated account manager to report any complaint related to non-technical issues.

4.2 The Access Provider Network

- 4.2.1 For the Access Seeker's own safety, and so that services supplied by the Access Provider are not disrupted, the Access Seeker must help safeguard the Access Provider' Network. The Access Seeker must:

- (a) Follow the Access Provider' reasonable directions when connecting anything to the Access Provider' Network.
- (b) Only allow people authorised by the Access Provider to work on or around the Access Provider' Network and
- (c) make sure everyone the Access Seeker is responsible for also meets these obligations.

5 Planned Outages and Maintenance

5.1 General Obligations

- 5.1.1 The Access Provider may suspend any MDS-U in order to carry out Planned or Emergency Maintenance.
- 5.1.2 In the case of Planned Maintenance, the Access Provider shall use its best endeavors to carry such activity during the night or at weekends or other quiet periods.
- 5.1.3 The Access Provider shall give ten (10) Working Days' notice of each Planned Maintenance activity affecting a particular MDS-U Service or group of MDS-U Services. This shall include the circuits affected, the date and time of the suspension and the likely duration of the suspension.

- 5.1.4 The Access Provider shall give three (3) Days' notice of each Emergency Maintenance activity affecting a particular MDS-U Service or group of MDS-U Services. This shall include the circuits affected, the date and time of the suspension and the likely duration of the suspension.
- 5.1.5 In cases of Emergency Maintenance, the Access Provider shall advise the Access Seeker within five (5) hours after service is restored with a report of the cause of the Fault.
- 5.1.6 The Access Provider shall use its reasonable endeavours to take into account the reasonable operational concerns of the Access Seeker before implementing any Planned Maintenance.

ANNEX 1 - Unmanaged MDS (MDS-U): Process

An application for Unmanaged MDS (MDS-U) should follow the process set out in this annex.

Step/Stage	Responsibility	Description	Expected Timeframe
MDS-U Request	Access Seeker	Provide information regarding MDS-U Request by the Access Seeker to the Access Provider	Access Seeker's choice
Assess Request	Access Provider	Return to Access Seeker if incomplete information	Up to five (5) Working Days unless extended
Field Study	Access Provider	Which includes Desk study, Field study, solution design & architecture	Thirty (30) Working days
Confirm to Proceed	Access Seeker	If application is to proceed to a binding Service Order, then Access Seeker must confirm (failing which the application would be deemed withdrawn)	Fifteen (15) Working days
Implementation	Access Provider	Implementation of the requested Unmanaged MDS (MDS-U) connection as described in the Field Study after the confirmation by Access Seeker	Based on the proposed plan (Field Study)

For Charges, please refer to Schedule 3 (Pricing).

SCHEDULE 6.4 -

SERVICE DESCRIPTION FIBER FRONTHAUL SERVICE (FFS)

1. THE SERVICE

Service Description

- 1.1 The Fibre Fronthaul Service (FFS) is a point-to-point provision of one Fiber Cable between one Baseband Unit (**BBU**) and one Remote Radio Head (**RRH**) of the Network of an Access Seeker. Any additional FFS required between one BBU and an additional RRH shall be treated as a separate Service Order, and shall be charged accordingly.
- 1.2 The Service will provide point-to-point dedicated connectivity, between the Equipment of the BBU and of the RRH, as required.
- 1.3 The Service is available to Access Seekers holding an Individual Mobile Telecommunications License.
- 1.4 The Network demarcation of the FFS Service is the point at each end of the Fiber Cable. The Access Seeker will have access to the FFS Service at the telecom room of the Access Seeker's building or the Access Provider's Point of Presence.
- 1.5 Unless otherwise agreed with the Access Seeker, the demarcation point will be an ODF placed in the Access Seeker's building where the FFS is required; or the Point of Presence. The ODF will be owned by the Access Provider. No physical access shall be granted to the Access Seeker to the Access Provider's ODF and the interface shall be terminated by the Access Provider's staff at the Access Provider's ODF at both ends and handed over to the Access Seeker's for connecting the FFS.

DEFINITIONS

Capitalised terms not defined in this Service Description are defined in Schedule 8 - (Dictionary) of the Reference Offer. Terms defined in this Service Description are specific to it.

Baseband Unit (BBU) means the unit responsible for processing the baseband signals, where "baseband signal" refers to the signal from a Remote Radio Head that is unmodulated, via an optical interface. The BBU is connected to the RRH through CPRI (Common Public Radio Interface) Fibre Cables.

Block means a geographical area within the Kingdom of Bahrain as defined by the Ministry of Works, Municipalities Affairs and Urban Planning.

FFS means the Fiber Fronthaul Service.

FFS Operations Manual means the operations manual set out at Annex 4 of this Schedule 6.4.

FFS Service Commencement Date means the date of successful implementation and notified handover of the FFS Service by the Access Provider to the Access Seeker on the Access Delivery Date, which shall take place immediately following completion of testing as set out in FFS Operations Manual.

Installation means the installation of an individual FFS Service as described in paragraph 1 of this Service Description.

Installation Charges means the Charges referred to as Make Ready and relevant installation Charges set out under the FFS section of Schedule 3 - (Pricing) of the Reference Offer. **Minimum Service Period** means a minimum period of twenty-four (24) calendar months for which the FFS Service will be provided, such period commencing from the FFS Service Commencement Date.

Remote Radio Head (RRH) means a remote radio transceiver that connects to the BBU via an optical interface.

Renewed Minimum Service Period means an applicable minimum period of one (1) month for which the FFS Service shall be provided, such period commencing from the expiry of a Service Period.

Service Period means the Minimum Service Period or Renewed Minimum Service Period.

2. TERMS

Use of Service

- 2.1 The FFS Service shall only be made available to connect the BBU to the RRH. The Access Seeker may not resell the FFS Service to another Licensed Operator.
- 2.2 Where the Access Provider reasonably suspects a breach of paragraph 2.1, the Access Provider may undertake an investigation of the FFS Service as provided to the Access Seeker.
- 2.3 The Access Provider shall notify the Access Seeker at least twenty-four (24) hours in advance of any inspection the Access Provider intends to conduct as part of the investigation.
- 2.4 The Access Seeker shall upon request and immediately provide the Access Provider with all required access to ensure that the investigation is reasonably conducted including but not limited to access to sites and locations hosting the BBU and RRH.
- 2.5 Pursuant to the investigation set out in 2.2 above and where the Access Provider has reasonable grounds to suspect that the Access Seeker is in breach, the Access Provider, it may refer the matter as a complaint for investigation by the Authority and, subject to the Authority's approval, suspend the FFS Service until the Authority has come to a conclusion pursuant to its investigation.

Supply of Service

- 2.6 The Access Seeker shall submit a Service Order to the Access Provider to request supply of the FFS Service, in the manner communicated by the Access Provider as set out in the FFS Operations Manual.
- 2.7 The Access Provider and Access Seeker shall follow the process outlined in the FFS Operations Manual.

3. CHARGES

- 3.1 The Access Seeker shall pay to the Access Provider the relevant Charges determined in accordance with Schedule 3 - (Pricing) of the Reference Offer. This shall include relevant Monthly Recurring Charges and relevant Non-recurring Charges associated with the Application, Field Study/ies and Installation processes, notwithstanding that the Access Seeker may pay directly the Approved Contractor for materials and installation works.
- 3.2 All Charges and sums due from one party to the other under this Agreement are exclusive of VAT. Any VAT shall be charged in accordance with the relevant regulation in force at the time of making the taxable supply and shall be paid by the paying party following receipt from the billing party of a valid VAT invoice.

4. SERVICE LEVELS

The Access Provider shall provide the FFS Services in accordance with the Service Levels specified in Schedule 7- (Service Levels) of the Reference Offer.

ANNEX 1 - PROVISIONING VALIDATION TEST

The following criteria will be used to validate the required services:

Provisioning Validation Test	
Acceptance Criteria	Link Verification using Optical Time Domain Reflectometry
Test Result	Copy provided to the Access Seeker's upon request at time of testing

ANNEX 2 - Fiber Fronthaul Service (FFS): PROCESS

An application for FFS should follow the process and policies set out in this ANNEX 2.

Step/Stage	Responsibility	Description	Expected Timeframe	Charges
FFS Request and Inquiry	Access Seeker	Provide information regarding FFS request	Up to Access Seeker	No
Assess Request	Access Provider	Return to Access Seeker if incomplete information	Up to five (5) Working Days unless extended as per schedule	BD 100.00 (NRC).
				As a processing application fee per FFS request per connection
Solution Design	Access Provider	Which includes Desk study, Field study, solution design architecture,	Thirty (30) Working days	Based on Time and Materials
Confirm Proceed	Access Seeker	If application is to proceed then Access Seeker must confirm or withdraw	Fifteen (15) Working days	No fees. Proposal remains valid for Fifteen (15) Working days.
Implementation	Access Provider	Implementation of the requested FFS as provided in Solution Design stage after the confirmation by Access Seeker	Based on the proposed plan	As per the contract Proposed solution Design

ANNEX 3 - Fiber Fronthaul Service (FFS): Connectivity Layout

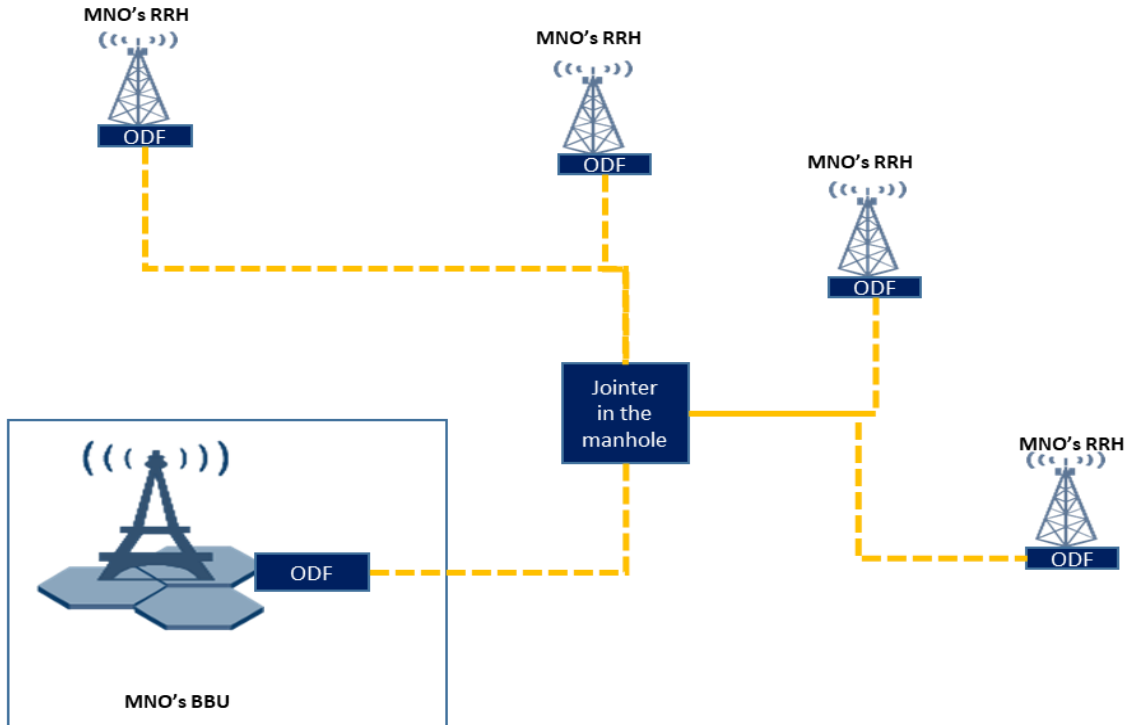

LEGENDS:

ODF

Passive Infrastructure pairs between BBU and RRH sites



MNO's RRH



MNO's Mobile radio site/BBU



Passive Infrastructure between BBU to RRH

Jointer in the manhole

Distribution of Passive Infrastructure pairs between BBU and RRH sites

ANNEX 4 TO SCHEDULE 6.4

Fronthaul Fibre Service (FFS) Operations Manual

This document describes the onboarding, provisioning, fulfilment and fault handling process for the Fronthaul Fibre Service between the Access Provider and the Access Seeker. This document forms an integral part of the Access Provider's Reference Offer and of Schedule 6.4.

1. Onboarding

1.1 Onboarding Requirements

1.1.1 Access Seeker Onboarding

- (a) The Access Seeker shall review, acknowledge, and sign for Access Provider's counter signature the Supply Terms (Schedule 9) of the Reference Offer.
- (b) The Access Seeker shall have in force and maintain for the term of the Agreement a broad form of public liability insurance to the value of at least BD 250k and property insurance for the assets used in relation to this Agreement to the value of at least BD 100k.
- (c) These policies shall be with a licensed insurance company in the Kingdom of Bahrain and on terms and for coverage limited by only standard industry exclusions or exceptions.

1.1.2 Credit Security

- (a) The Access Seeker shall have in force and maintain security as requested by the Access Provider as required under the Reference Offer Supply Terms.

1.1.3 Licensing and Authorizations

- (a) The Access Seeker shall comply with the terms and conditions set out in the Reference Offer and relevant Service Descriptions, including obtaining any prior authorizations and shall maintain the required licenses as provided for by the Regulator.

1.1.4 Confidentiality and Non-Disclosure

- (a) The Access Seeker is required to execute the Access Provider's Non-Disclosure and Confidentiality Agreement and comply with any information protection.

1.1.5 BNET BSS

- (a) The Access Provider allows the Access Seeker to integrate via API to the Access Provider's BSS, which is designed based on the telecom standard framework for business process, the enhanced Telecom Operations Map ("eTOM") for placement of Service Order(s) and Service Request(s).

- (b) The Access Provider also provides an interface portal (the Access Provider Portal) for Access Seeker who do not have the capability to integrate via API. The Access Provider Portal is a standard Portal that may not provide the same enhancements and benefits that an Access Seeker would receive through API integration.
- (c) The Access Provider recommends access via API integration to its BSS.

1.1.6 Process for API Integration

- (a) If the Access Seeker opts for API integration, it shall contact the Access Provider Relationship Manager for API documentation.
- (b) Access Seeker will be required to undergo a trial phase for testing the API integration and will be required to sign off on the successful completion of the testing phase. Without limitation, the Access Seeker and Access Provider will confirm the following where applicable:
 - (i) The system integration has been completed;
 - (ii) The Access Seeker has portal access and credentials;
 - (iii) Network aggregation is implemented and tested;
 - (iv) A billing test on the relevant Service is confirmed; and
 - (v) Service provisioning of for the relevant Service is confirmed.
- (c) The Access Provider should ensure that all communications with the Access Seeker should be confidential and shall not be disclosed to other Licensed Operators.

2 Fulfillment

2.1 Request to Answer

- 2.1.1 The Request to Answer process is a pre-order management process. This process comprises of activities relevant to managing Access Seeker information requests across all communication channels (Access Seeker interfaces).
- 2.1.2 Specific information requests or product requests from the Access Seeker are qualified and addressed.
- 2.1.3 Pre-order Management consists of a set of functions across the API interface that enables the interaction before the Access Seeker order can be created.

2.2 FFS Address & Service Availability Check

- 2.2.1 Prior to the Access Seeker placing a Service Order for the relevant Service, it is necessary to check whether the service infrastructure is available. The Access Seeker is provided with a tool to conduct varying levels of pre-qualification checks before submitting a Service Order.
- 2.2.2 In the circumstances where the Access Seeker chooses to submit a Service Order following the pre-qualification checks, the Access Provider shall verify the Service Order through an **Address Availability Check** – to identify whether the Access Seeker Wireless Radio Site address exists in the

Access Provider Address database which is updated by the IGA (Information & eGovernment Authority) through their address database.

2.2.3 These qualification steps identify whether the Fulfilment request raised by the Access Seeker can be accepted. An Address Availability Check can be performed using the portal and the API integration and are performed by the Access Seeker.

2.2.4 The details of using the portal & API integration to interact with business processes mentioned in this Operational Manual are detailed in the LO API documentation shared by Access Provider.

2.3 FFS Service Request

2.3.1 In the event neither the address nor the service availability check is successful, the Access Seeker may:

- (a) Where the address is not available on the Access Provider's database, raise a Service Request to add the address to the Access Provider's address database; and
- (b) Raise a Service Request to provision the address with a FFS Service based on the Access Provider's resources and availability.

2.4 Service Requests

2.4.1 If the Access Seeker opts for any of the options set out in paragraph 2.3.1 above, this shall be considered as a Service Request.

2.4.2 The Access Provider will, on a monthly basis, update the address list in the Access Provider Database which the Access Seeker shall be privy to if integrated through API or through access of the Portal. This information is provided by the IGA.

2.4.3 The Access Seeker is required to provide the information requested as per the form and mandatory fields set in the Portal/API in order to submit a Service Order. It is important for the Access Seeker to adhere to these mandatory fields, or otherwise may run the risk of having its Service Request rejected.

2.4.4 If Access Seeker finds that the address does not exist through the address availability check while raising the Service Order, the Access Seeker shall be eligible to raise a Service Request through the Portal or API for an address addition.

2.4.5 Every submitted Service Request will be allocated a unique identifier for tracking and managing the Request.

2.4.6 As part of the Service Request, the Access Seeker shall input the required information as per the below list, or in accordance with the required fields set out in the Portal/API:

- (a) Flat number– To be provided for address having flat number.
- (b) Building number
- (c) Street name
- (d) Road Number
- (e) Block Number
- (f) City

- (g) Area
- (h) Country

- 2.4.7 The Access Seeker is required to attach mandatory End-User proof of address documents when raising a Service Request for address addition, such as a valid address card or any documentation which may be deemed as necessary by the IGA authority to validate the Access Seeker's Wireless Radio Site.
- 2.4.8 The Access Seeker shall be responsible to ensure the validity, authenticity, and completeness of the above-mentioned attachments.
- 2.4.9 Where any of the documentation is considered as invalid, the Service Request shall be reassigned to the Access Seeker for rectification.
- 2.4.10 Where the address is validated by the IGA and accepted, such address will be updated in BNET database and the Service Request shall be closed. Whilst the address may be updated, this does not guarantee that the Service is covered. In this case, the Access Seeker may raise a Service Request for a cost assessment (please see refer to the process below on a cost assessment Service Request).
- 2.4.11 For the avoidance of doubt, if any of the above information requested as inputs from the Access Seeker have not been provided, the Service Levels in Schedule 7 of the Reference Offer will not be applicable.
- 2.4.12 The Access Seeker can issue a pre-order feasibility Service Request, which must contain the Service/product order details along with the requesting address.
- 2.4.13 The Access Seeker must verify the requesting address and the Service/product details (including but not limited to the Service/Product ID, Service feature requirements, i.e. committed bandwidth). These must be included in accordance with the mandatory fields in the Access Provider's Portal/API integration.
- 2.4.14 Upon receipt of the Service Request, the Access Provider will assess the Service Access Resources availability at the intended address location and will provide the status of Service provision in accordance with Schedule 7 of the Reference Offer.
- 2.4.15 Service Orders raised subsequent to Service Requests should refer the relevant pre-order feasibility Service Request(s).
- 2.4.16 For the avoidance of doubt, the Access Seeker's Service Request shall be rejected if:
 - a. it does not specify a valid address; or the address cannot be verified by the authority (IGA); or
 - b. it does not provide the required inputs delineated above; or
 - c. it does not have the authorizations provided for by its License to avail of the Service.
- 2.4.17 No service commitment or network resources reservation should be assumed to be done as a result of an unapproved cost assessment Service Request.

2.5 Order to Payment – Fulfilment of Service Orders

- 2.5.1 The Access Seeker may submit a New Connection ("New Provide") Service Order through API integration or via the Access Provider Portal.

- 2.5.2 The Access Provider will process these Service Orders as described below:
- (a) Service Orders will only be processed during the Access Provider's Working Hours.
 - (b) The Access Provider will acknowledge receipt of the Service Order within fifteen (15) minutes of receipt of the Service Order
 - (c) For Service Orders submitted outside of Working Hours, the Access Provider shall acknowledge the Service Request within fifteen (15) minutes following the start of the first Working Hour after receipt of the Service Order.
- 2.5.3 A Service Order shall be considered invalid if:
- (a) it is incomplete or incorrect or illegible or cannot reasonably be understood;
 - (b) it does not properly identify the Wireless Radio Site;
 - (c) a valid written End User Consent cannot be produced by the Access Seeker to support the Service Order; and/or
 - (d) it resulted from a processing error.
- 2.5.4 The Access Provider shall, within two (2) Working Days, notify the Access Seeker if the Service Order is accepted or rejected and where applicable, state the required corrections. If a notification is not provided within two (2) Working Days of receipt of the relevant Service Order, the Service Order shall be deemed accepted by the Access Provider.
- 2.5.5 Within five (5) Working Days from the date of the acceptance of the Service Order, the Access Provider shall notify the RFS Dates to the Access Seeker, as specified in Schedule 7 – (Service Levels) of the Reference Offer. The Access Provider reserves the right to reject the Service Order during this stage if it is found that the FFS Service is not supported or if the Access Provider's point to point Service Access Resources Network does not extend to the requested area within the Kingdom of Bahrain.
- 2.5.6 The Access Seeker shall book service installation initial appointment within 2 working days for service installation once RFS date is notified to Access Seeker. If the Access Provider's technician shall be present at the Wireless Radio Site to install a FFS Service, and if, for any reason, the Access Seeker and/or the End User cannot be available on the Expected RFS Date for such installation, the Access Seeker shall give the Access Provider a minimum written notice of one (1) Working Day. The revised Expected RFS dates are then set following the below principles.
- (a) The Access Seeker shall propose the next earliest date(s) for installation appointment which the Access Provider's technician would be available for the installation which shall be a maximum of two (2) Working Day notice from the day of the missed appointment.
 - (b) The previously notified Expected RFS Date is also modified and is set apart from the revised Expected RFS Date by the Maximum Validation Time of three (3) Working Days. The revised Maximum RFS Date is then set equal to the revised Expected RFS Date.
 - (c) The Access Provider shall send the Access Seeker a Notification of revised Expected RFS Date.
- 2.5.7 In addition, if at least one of the following two conditions is met (i) the Access Seeker does not provide the Access Provider a minimum written notice of two (2) Working Days to inform of its unavailability; or (ii) the Access Provider sends a technician who is not able to access the site to install the FFS Service,

then except for the cases of Force Majeure affecting the Access Seeker, the Access Seeker is liable to pay the installation and configuration charge for the requested FFS Service as specified in Schedule 3 - (Pricing) of the Reference Offer. In such case, the modification and Notification of the revised Expected RFS Date and the revised Maximum RFS Date follow the same principles as described in paragraph 2.5.6.

- 2.5.8 The Access Provider's technician shall attend and access the Access Seeker's Wireless Radio Site or the Wireless Radio Site during Working Hours and at least have called the Access Seeker's representative, if it appears that the Access Seeker's technician is not present at the relevant time (and where requested provide evidence of this). The Access Seeker shall, in this case, be liable to pay only the incurred man-day costs of the Access Provider technician.
- 2.5.9 In addition, if the Access Provider does not provide the Access Seeker with a written notice of a minimum of two (2) Working Days to rearrange a site visit under paragraph 2.5.8 above, then the Access Provider is liable to waive an amount equal to one installation and configuration charge for the FFS Service.
- 2.5.10 Subject to the Access Seeker fulfilling its obligations set out in service description, the Access Provider shall provide, and the Access Seeker shall acquire the FFS Service either within the standard timescales or by the Exceptional Delivery Date as appropriate.
- 2.5.11 Subject to any other agreed arrangement between the Access Provider and the Access Seeker for the installation of FFS, the Access Provider (including its approved contractor) shall arrange for the installation and supply of the Fibre Cable and shall install such Fibre Cable from the RRH to the BBU (up to a maximum point-to-point distance of one (1) kilometre, measured in a straight line, whereas the actual distance of the fibre cable route on the ground could exceed this one (1) kilometre) on the Access s Seeker's behalf. The Access Provider shall prepare a quotation for the supply of the fibre cable material and the installation works for the fibre cable route until the demarcation points (as explained in the clause below) using the rates for time and material as set out in Schedule 3 (Pricing) - Annex 1. The Access Provider shall provide this quotation to the Access Seeker and following the Access Seeker's approval, shall conduct the works.
- 2.5.12 The Access Provider shall be responsible for any duct built and for deploying Fibre Cable beyond the demarcation point being the boundary of the plots where the BBU or RRH are located. The Access Seeker shall meet the costs of such installation works in accordance with the provisions of Schedule 3 - (Pricing) of the Reference Offer.
- 2.5.13 The provision of the FFS Service is subject to availability of space, capacity and related Facilities.
- 2.5.14 When provisioning a Service Request requiring new duct build, the Access Provider is responsible for construction of the duct on public land up until the demarcation point being the boundary of the plots where the BBU or RRH are located. The rental for new Fibre Cable associated with this duct build shall be charged at the rate set in Schedule 3 – (Pricing) of the Reference Offer.

- 2.5.15 A Service Order shall be considered invalid if:
- (a) it is incomplete or incorrect or illegible or cannot reasonably be understood;
 - (b) it does not properly identify the Wireless Radio Site;
 - (c) a valid written Wireless Radio Site landlord consent cannot be produced by the Access Seeker to support the Service Order; and/or
 - (d) it resulted from a processing error.
- 2.5.16 At the time of rejection, the Access Provider shall provide sufficiently detailed written reasons for rejection to the Access Seeker.
- 2.5.17 The SLAs in schedule 7 shall only be applicable to forecasted Service Orders in line with Schedule 5 (Forecasting) of the Reference Offer.
- 2.5.18 A Service Order must be in the format notified by the Access Provider from time to time and be submitted through an online digital interface notified to the Access Seeker by the Access Provider, from time to time.
- 2.5.19 Only in the case where the online digital Portal or the API integration setup mechanisms are not accessible, electronic mails shall be accepted as a communication mechanism.
- 2.5.20 The Access Seeker's Billing Account must be active and not in a suspended state in order for the Access Provider to accept and proceed with the Service Order.
- 2.5.21 Access Seeker's Wireless Radio Site permissions & site readiness is the responsibility of Access Seeker to communicate to the Access Provider.
- 2.5.22 The time slots with regard to appointment rebooking will be made available to the Access Seeker two days from the date of initiating the re-booking of appointment.

Projects

- 2.5.23 For New Connections of more than fifteen (15) sites, the Access Seeker may request the Access Provider to consider such New Connections as one Project. Subject to agreement between the Access Seeker and Access Provider, the Project will be managed based on an agreed project plan between the Access Provider and Access Seeker.

2.6 Request to Change

- 2.6.1 In the event the Access Seeker elects to reschedule or cancel a Service Order past the point-of-no-return, the Access Seeker shall be charged rescheduling or cancellation charges in line with Schedule 3 (Pricing) if the rescheduling/cancellation request is made twenty- four (24) hours from the appointment date provided to the Access Seeker by the Access Provider. In such cases, the Service Levels set out in Schedule 7 shall be suspended until the appointment is booked.
- 2.6.2 The point of no-return shall be defined as the instance when the appointment date has been provided to the Access Seeker by the Access Provider, and prior to any visits made by the Access Provider to the Wireless Radio Site.

- 2.6.3 To initiate a change to an existing FFS Service used by the Access Seeker to supply a service to an End User, the Access Seeker shall provide the Access Provider with a properly completed FFS Change Request, in the format notified by the Access Provider from time to time, submitted by electronic mail (or other electronic format, which may include an online digital interface) to the address notified to the Access Seeker by the Access Provider, from time to time.
- 2.6.4 In addition to the rejection reasons set out at paragraph 2.5.5 the Access Provider may also reject a FFS Change Request if it is not submitted in accordance with paragraph 2.5.15.
- 2.6.5 The Access Provider may, in its sole discretion, elect to accept any FFS Change Request notwithstanding that there is any defect in that FFS Change Request, if the Access Provider considers that such defect does not have a material effect on the Access Provider's ability to process the FFS Change Request and provide the FFS Service. A FFS Change Request may comprise of any of the following:
- (a) External Relocation
 - (b) Internal Relocation
 - (c) Upgrade
 - (d) Downgrade
- 2.6.6 The Access Seeker shall submit the request to Access Provider for an internal relocation of the FFS Service, which comprises of the relocation of an Access Provider's ODF/Patch Panel inside the Wireless Radio Site/PoP to another location within the same Wireless Radio Site/PoP. The Access Provider shall charge a once off charge in accordance with Schedule 3 – (Pricing) of the Reference Offer for the internal relocation of the existing FFS Service.
- 2.6.7 The Access Seeker shall send the request to the Access Provider for the external relocation or relocation of the FFS service, which will follow the same process of SLA criteria as new connection.
- 2.6.8 The Access Seeker shall not be liable for any termination or additional recurring charges in respect of a request for a FFS Amended Service which is for a relocation. The Access Provider shall charge a once off charge in accordance with Schedule 3 - (Pricing) of the Reference Offer for the relocation unless the Access Seeker requires both Connections to be operational in parallel. The Access Provider shall not terminate the Connection which is subject to relocation until the Service Commencement Date of the new Connection.
- 2.6.9 The Access Seeker shall be entitled to amend a FFS Service by requesting a FFS Amended Service where this is an Upgrade by providing an Upgrade Request to the Access Provider. The Access Seeker shall only be entitled to Downgrade the throughput of a Connection till the Minimum Service Period has expired. Where the Access Seeker requests a FFS Amended Service, then the Service order procedure set out in this Service Description shall apply to that request. Where the Access Seeker requests a FFS Amended Service that requires any new Network resources and/or facilities then a new Minimum Service Period shall commence and the Access Provider shall provide a FFS Amended Service for the new Service Period.

- 2.6.10 The Access Seeker shall not be liable for any termination or additional recurring charges in respect of a request for a FFS Amended Service which is for a relocation. The Access Provider shall charge a once off charge in accordance with Schedule 3 - (Pricing) of the Reference Offer for the relocation unless the Access Seeker requires both Connections to be operational in parallel. The Access Provider shall not terminate the Connection which is subject to relocation until the Service Commencement Date of the new Connection.
- 2.6.11 The Access Provider will provide an RFS date with regard to an external relocation that is not within the Forecasted Orders and where the new intended address is not covered by Service Access Resources. For the avoidance of doubt, the SLAs in Schedule 7 will not apply to these Service Orders.
- 2.6.12 For any service upgrade that is not within the Access Seeker's forecasted Service Orders, the SLAs denoted in Schedule 7 will not apply, and the Access Provider shall provide an RFS date based on network capacity availability.

2.7 Exceptions

- 2.7.1 The Access Provider shall, subject to the exceptions, limitations and conditions specified in this Service Description and/or Supply Terms, provision and deliver the FFS Service on or before the RFS Date and in accordance with Schedule 7 - (Service Levels) of the Reference Offer.
- 2.7.2 The Parties acknowledge and accept that exceptional circumstances, such as those set out below, may give rise to delays in any stage of the provisioning and delivery of a Service Order. If the occurrence of any of the events below takes place, the Access Provider shall communicate the Exceptional Delivery Date to the Access Seeker and shall not be held liable for the Service Level Penalties. The exceptional circumstances shall only comprise of:
- (a) a Force Majeure Event or a Regulatory Event; or
 - (b) Emergency Maintenance; or
 - (c) any material breach of the Access Seeker's obligations.
 - (d) The Access Provider shall, in notifying the Access Seeker of the Revised Delivery Date, provide sufficient evidence to justify the reasons for the delay of the delivery.
- 2.7.3 The Access Provider shall not be obliged to further process a Service Order where:
- (a) the relevant FFS Service cannot meet Service Qualification; or
 - (b) following the provision of reasonable notice by the Access Provider, an authorized person from the End User or the Access Seeker is not available to provide further information when requested.

2.8 Notification of Completion of Order

- 2.8.1 The Access Provider shall, on the same Working Day of completion of a Service Order, notify the Access Seeker of completion.
- 2.8.2 In the case of a Service Order, the Access Provider is entitled to rely on an evidence that the relevant End User:
- (a) has given a valid End User Consent in relation to the requested Service Order; and

(b) in the case of a Change Request understands and has requested the Change.

2.9 Termination to Confirmation

- 2.9.1 Where the Minimum Service Period has not expired, the Access Seeker shall be entitled to terminate the FFS Service on at least one (1) month's written notice to the Access Provider and shall be liable to pay liquidated damages as calculated by the following formula.
- 2.9.2 Formula for calculating liquidated damages: $LD = MRC \times (24 - M)$ where:
LD = liquidated damages to be paid.
MRC = Monthly Recurring Charge for the FFS Service.
M = number of months between the Actual RFS Date and the removal order date rounded-up to the next full month.
- 2.9.3 The Access Seeker shall not be liable to pay liquidated damages where the Access Seeker terminates the FFS Service as a result of and/or arising out of a material breach of the Reference Offer by the Access Provider.
- 2.9.4 The Access Seeker expressly acknowledges that liquidated damages as calculated above form a reasonable pre-estimate of the loss which the Access Provider would suffer as a result of early termination by the Access Seeker. Such liquidated damages shall be the Access Provider's sole and exclusive damages or monetary remedy for such early termination.
- 2.9.5 Following the expiry of any Minimum Service Period the FFS Service shall be automatically renewed for successive Renewed Minimum Service Periods unless and until terminated by the Access Seeker. During the Renewed Minimum Service Period, the Access Seeker may terminate the FFS Service subject to providing the Access Provider with a written termination notice of at least one (1) month prior to the expiry of the Renewed Minimum Service Period. In the event that the Renewed Minimum Service Period expires, and the Access Seeker does not provide any written termination notice as above, the FFS Service shall renew for a further Minimum Service Period.
- 2.9.6 The Access Provider may upon providing three (3) months' written notice to the Access Seeker and subject to the approval of the Regulator, vary the FFS Service or withdraw the FFS Service relating to the terms and Annexes in this Service Description, by issuing a revised Service Description.
- 2.9.7 Unless the Access Provider and Access Seeker agree otherwise at the time, any withdrawal or variation of the FFS Service, or any amendment to the Charges payable for the FFS Service in accordance with this Service Description and Schedule 3 – (Pricing) of the Reference Offer, shall also apply to existing FFS Services provided under the Supply Terms, which shall continue in force in accordance with its terms and conditions until renewed or terminated in accordance with this Service Description or the Supply Terms

3 Fault Handling and Resolution

3.1 Faults

- 3.1.1 The Access Provider's responsibility for faults in the FFS Service is limited to the following:
- (a) Any fault that affects the FFS and/or in the Access Provider's Network, Systems, Access Provider Equipment where such fault is not caused, whether directly or indirectly, by the Access Seeker's actions or omissions;
 - (b) Any fault that the FFS and/or in the Access Provider's Network, Systems, Access Provider Equipment where such fault is directly caused by the Access Provider's action or omission.
- 3.1.2 The Access Seeker is responsible for any fault that affects the FFS and/or in the Access Provider's Network, Systems, Access Provider Equipment where such fault is caused, whether directly or indirectly, by the Access Seeker's actions or omissions, whether through negligence or otherwise.
- 3.1.3 The Access Seeker shall be responsible for providing an initial fault diagnosis and reporting for any fault reported to the Access Seeker by its End-Users. The Access Seeker must ensure that its fault reporting service is competent and sufficiently resourced as per the quality standards set in the industry.
- 3.1.4 Pursuant to paragraph 0 above and prior to notifying the Access Provider of a fault, the Access Seeker must:
- (a) Confirm the presence of a fault;
 - (b) Perform an initial fault diagnosis to identify where the fault has arisen;
 - (c) Use all reasonable endeavors to investigate the fault and find out all relevant information from its End-User;
 - (d) Confirm that the fault falls under the Access Provider's responsibility with a clear explanation as to why it considers this to be the case.
- 3.1.5 When the Access Seeker has met the conditions set out in paragraph 0 above, it must report any fault that the Access Provider falls under the Access Provider's responsibility, as set out in paragraph 3.1.1 above, to the Access Provider and provide reasonable information regarding the fault by raised a Customer Problem ticket.
- 3.1.6 If the fault is found to be outside of the Access Provider's responsibility, as set out in paragraph 3.1.1 above, or where the Access Provider cannot confirm the presence of a fault, the Access Provider may charge the Access Seeker on a time and materials basis.

3.2 Fault Resolution

- 3.2.1 The Access Seeker will facilitate contact with any relevant End User of the Access Seeker and/or arrange a site visit this is reasonably required by the Access Provider to clarify the nature of, or undertake work to fix, any Reported Fault. the Access Provider may communicate End User of the Access Seeker directly so long as such communications are confined to technical matters directly concerning the Reported Fault.

- 3.2.2 Upon the Access Provider' acknowledgement of a Reported Fault that is the Access Provider' responsibility, the Access Provider will:
- (a) diagnose and fix the Reported Fault;
 - (b) following the initial diagnosis, provide an indication to the Access Seeker of the likely time to fix the Reported Fault (Response, provided that the Access Provider has no obligation to provide such indication if the Reported Fault is fixed at the time of initial diagnosis.

3.3 Reporting Faults to the Access Provider

- 3.3.1 The Access Provider has two automated channels which allows the Access Seeker to create customer trouble tickets:
- (a) Portal
 - (b) API Integration
- 3.3.2 The two channels allow Access Seekers to:
- (a) create a new trouble ticket;
 - (b) retrieve status and updates on a trouble ticket; and
 - (c) Receive ticket resolution and closure updated along with root cause.
- 3.3.3 Faults can be logged 24 hours a day, seven days a week.
- 3.3.4 The Access Seeker must use the Access Provider Portal or API Integration for reporting all faults regarding the FFS Service. If the Access Seeker uses any other method to report a fault, the fault will not be acknowledged by the Access Provider or attended and the Service Levels as defined will not apply to that fault.
- 3.3.5 Where the Access Provider advises the Access Seeker that Portal /API is unavailable, the Access Seeker must submit fault reports to the Access Provider by calling the Access Provider Call Center. The Access Provider will use all reasonable endeavors to advise Access Seekers immediately upon becoming aware that the Portal /API is unavailable.
- 3.3.6 Once the Access Seeker has provided initial fault diagnosis, determined that it requires the Access Provider assistance to resolve the fault, the following information is required when reporting a fault:
- (a) confirmation that the initial fault diagnosis has been completed;
 - (b) contact name and phone number of the Access Seeker staff member logging the fault;
 - (c) contact name, phone number, and alternate phone number of the End User experiencing the fault (where appropriate);
 - (d) End User's Service Identifier for service that is experiencing the fault (where appropriate);
 - (e) fault type and description;
 - (f) time the fault occurred;
 - (g) address and contact details for the site of the fault (where appropriate); and
 - (h) any other relevant information.
- 3.3.7 If any of the above information set out from (a) to (h) in paragraph 3.3.6 above is not provided, the Service Levels in the Schedule 7 of the Access Provider Reference Offer will not apply.

3.4 Fault Report Acknowledgement

3.4.1 When a fault report is received, the Access Provider will advise the Access Seeker, acknowledging receipt of the fault report within specified SLA in schedule 7.

3.5 Fault Tracking

3.5.1 All faults will be logged in Portal /API integration and the Access Seeker will be given a fault reference number where the access seeker can get the update on the raised trouble tickets and the progress to restore the service.

3.5.2 Where the Access Provider subsequently becomes apparent that the fault restoration time cannot be met, the Access Provider will advise the Access Seeker of a revised fault restoration time.

3.6 Access Seeker Wireless Radio Site Visit

3.6.1 If the Access Provider identifies the need to send a field engineer to the end-user, the Access Provider will update Access Seeker trouble ticket in portal/API integration.

3.6.2 The Access Seeker's is responsible for coordinating site access, visit appointment and any required outage window with the relevant landlord.

3.6.3 In case the landlord does not respond to the Access Provider calls to confirm appointment, the KPI will be stopped and access seeker will need to re-book appointment and inform the Access Provider with new appointment booked.

3.7 Fault Types

3.7.1 If the issue can be fixed remotely, the Access Provider will fix the issue and the customer trouble tickets will be updated accordingly.

3.7.2 In the event where the issue is within passive or active resources, a planned outage will be required and the Access Provider will inform the access seeker on planning outage timings.

3.7.3 access seeker representative to be available at the time of the end-user visit to verify and accept the resolution of the end-user fault.

3.8 Fault Closure

3.8.1 Once the fault has been resolved, the Access Provider will notify the Access Seeker via Portal/API integration that the fault has been resolved, confirm the reference number and, where possible, provide the cause of the fault and any actions taken to reach resolution.

3.9 Emergency and Core Network Faults

3.9.1 Emergency faults reported to the Access Provider will be treated on a case-by-case basis. In the first instance, the Access Provider will propose a temporary solution. However, in the absence of a viable temporary solution, the Access Provider may schedule a callout to respond to faults, or to emergency faults relating to mass outage that impacts an entire block or area.

4 Complaints

4.1 This section deals with Access Seeker enquiries where the Access Seeker is not satisfied with a product and/or handling and timeliness of an enquiry.

4.1.1 Access Seekers can reach their designated account manager to report any complaint related to none-technical issues.

4.1.2 Access seeker can be raise their complaints through the portal and/or API integration

4.1.3 The Relationship Manager will acknowledge the receipt of the complaint within 2 working days.

4.1.4 A response to the complaint will be provided to the Access Seeker within 5 working days.

4.1.5 In case the Access Seeker finds the provided solution is not satisfactory, the complaint can be escalated to Head of relationship manager.

4.2 The Access Provider Network, the Access Provider Owned Equipment and Property.

4.2.1 For the Access Seeker's own safety, and so that services supplied by the Access Provider are not disrupted, the Access Seeker must help safeguard the Access Provider' Network and the Access Provider Owned Equipment. The Access Seeker must:

- (a) Follow the Access Provider' reasonable directions when connecting anything to the Access Provider' Network or any the Access Provider Owned Equipment
- (b) Only allow people authorised by the Access Provider to work on or around the Access Provider' Network or the Access Provider Owned Equipment; and
- (c) make sure everyone the Access Seeker is responsible for also meets these obligations.

4.3 Access Seeker Responsibility towards the Access Provider Owned Equipment

4.3.1 At the time any the Access Provider Owned Equipment is supplied, the Access Provider will use all reasonable endeavours to make sure it is safe, durable and approved for connection to the rest of the Access Provider' Network.

4.3.2 Where the Access Provider supplies the Access Seeker with any the Access Provider Owned Equipment, the Access Seeker will, where applicable:

- (a) leave the Access Provider Owned Equipment installed and not use it otherwise than in specified in the service description.
- (b) protect the Access Provider Owned Equipment from radio or electrical interference, power fluctuations, abnormal environmental conditions, theft and any other risks of loss or damage.
- (c) if the Access Provider Owned Equipment is lost, stolen or damaged, notify the Access Provider directly and pay for repairing or replacing it, except where the loss, theft or damage was caused by the Access Provider;
- (d) follow the Access Provider' reasonable directions when using the Access Provider Owned Equipment and never use the Access Provider Owned Equipment for purposes for which it is not designed; and

- (e) not encumber the Access Provider' title to the Access Provider Owned Equipment or expose such title to third Party claims and notify the Access Provider if it becomes aware of any third-Party claim.
- 4.3.3 When any the Access Provider Owned Equipment is no longer required the Access Seeker:
- (a) must return the Access Provider Owned Equipment to the Access Provider;
 - (b) will take reasonable care to avoid causing damage when returning the Access Provider Owned Equipment to the Access Provider and be responsible for any damage to the Access Provider Owned Equipment; and
 - (c) must pay all Charges for the Access Provider Owned Equipment until such time as it is returned to the Access Provider.

5 Planned Outages and Maintenance

5.1 General Obligations

- 5.1.1 The Access Provider may suspend any FFS in order to carry out Planned or Emergency Maintenance.
- 5.1.2 In the case of Planned Maintenance, the Access Provider shall use its best endeavors to carry such activity during the night or at weekends or other quiet periods.
- 5.1.3 The Access Provider shall give ten (10) Working Days' notice of each Planned Maintenance activity affecting a particular FFS Service or group of FFS Services. This shall include the circuits affected, the date and time of the suspension and the likely duration of the suspension.
- 5.1.4 The Access Provider shall give three (3) Days' notice of each Emergency Maintenance activity affecting a particular FFS Service or group of FFS Services. This shall include the circuits affected, the date and time of the suspension and the likely duration of the suspension.
- 5.1.5 In cases of Emergency Maintenance, the Access Provider shall advise the Access Seeker within five (5) hours after service is restored with a report of the cause of the Fault.
- 5.1.6 The Access Provider shall use its reasonable endeavors to take into account the reasonable operational concerns of the Access Seeker before implementing any Planned Maintenance and be carried in accordance with Schedule 7 of the Access Provider's Reference Offer.

**SCHEDULE 6.5 –
SERVICE DESCRIPTION CORE CONNECT AND LANDING STATION SERVICE (CCLS)**

1. THE SERVICE

Service Description

- 1.1 The Core Connect and Landing Station Service (CCLS) is a high-speed circuit that uses Dense Wavelength Division Multiplexing (DWDM) on the Access Provider's dedicated fibre within the Kingdom of Bahrain between:
- (a) two Access Seeker Core Sites; or
 - (b) (i) an Access Seeker's Core Site and (ii) a Landing Station.
- 1.2 The CCLS Service is provided with a bandwidth specified in Annex 1 of this Service Description.
- 1.3 The CCLS Service is available to Access Seekers holding an Individual Telecommunications License.
- 1.4 The CCLS Service is designed for an Access Seeker's own internal operations and not for provisioning a service to End Users. For example, it shall not be used to provide a service to any End User or where such service can be provided by another product in this Reference Offer, including but not limited to the Wholesale Data Connection (WDC) Service and/or the Mobile Data Service – Active (MDS-A).

2. DEFINITIONS

Capitalised terms not defined in this Service Description are defined in Schedule 8 - (Dictionary) of the Reference Offer. Terms defined in this Service Description are specific to it.

Access Seeker Core Site means a location in the Kingdom of Bahrain owned or controlled by the Access Seeker which hosts equipment for control functionality on its Network.

Landing Station means a location where international cables terminated inside the Kingdom of Bahrain, which provide cross-connection(s) between international carriers and Licensed Operators, are hosted.

CCLS Connection means an individual CCLS Service.

Customer Premises Equipment or **CPE** means that Equipment forming part of the CCLS at the Access Seeker Core Site or a Landing Station, respectively.

Minimum Service Period means an applicable minimum period of twenty-four (24) calendar months for which the CCLS Service shall be provided, such period commencing from the Service Commencement Date.

CCLS Amended Service means an CCLS Service that is amended by a Change Request.

CCLS Service means the service defined at paragraph 1 above.

CCLS Operations Manual means Annex 4 of this Schedule 6.5,

Renewed Minimum Service Period means an applicable minimum period of one (1) month for which the CCLS Service shall be provided, such period commencing from the expiry of a Service Period.

Service Period means the Minimum Service Period or Renewed Minimum Service Period.

3. TERMS

Use of Service

- 3.1 The CCLS Service shall only be made available to provide connectivity between (i) Access Seeker Core Sites, or (ii) a Landing Station and Access Seeker Core Site, and not any End User. The Access Seeker may not resell the CCLS Service to another Licensed Operator.
- 3.2 Where the Access Provider reasonably suspects breach of paragraph 3.1, it may refer the matter as a complaint for investigation by the Authority.
- 3.3 Where the Authority establishes after an investigation under paragraph 3.2 that an Access Seeker is not using the CCLS Service in accordance with this Service Description, the Access Provider without prejudice to any other rights and remedies under the Supply Terms may by immediate written notice suspend or terminate the specific CCLS Connection and the Access Seeker shall be liable to pay the Access Provider liquidated damages calculated in accordance with CCLS Operations Manual.

Supply of Service

- 3.4 The Access Seeker shall submit a Service Request to the Access Provider to request supply of the CCLS Service in accordance with the process set out in the CCLS Operations Manual.
- 3.5 Subject to the Access Seeker fulfilling all of its obligations set out in the CCLS Operations Manual, the Access Provider shall provide and the Access Seeker shall acquire the CCLS Service either within the standard timescales or by the Exceptional Delivery Date as appropriate.
- 3.6 The Service Level Terms shall apply to:
 - (a) New CCLS Connection – provide a new CCLS Service as requested by the Access Seeker;
 - (b) Upgrade or Downgrade;
 - (c) Hot and Cold Migration – changing the End User address of an existing CCLS Connection, requiring disconnection and reconnection of the CCLS Connection end point, including “hot migration” which is when the CCLS Connection is not disrupted and “cold migration” which is when the CCLS Connection can be disrupted;
 - (d) Reconfiguration – reconfigure technical parameters of an existing CCLS Connection; or (e) Cancellation – the Access Seeker requests the cessation of an existing CCLS Connection.

- 3.7 Further information relating to the applicable Service Level Terms and Service Level Penalties for the above is detailed in the Schedule 7 – (Service Levels) of the Reference Offer.

Amendment to the CCLS Service

- 3.8 The Access Seeker and Access Provider shall comply with the specific process set out for the Amendment to the CCLS Service in the CCLS Operations Manual. This covers scenarios whereby the Access Seeker requests an internal shift, Relocation, or an external shift. These processes shall be applicable to existing CCLS Services only.

Access Seeker Obligations

- 3.9 The Access Seeker shall provide the Access Provider with suitable space for, and access during Working Hours to, any Access Provider's Equipment required to be located in any building in which the CCLS Service is located within the control of the Access Seeker. If consent is required from a third party, the Access Seeker shall procure such consent. The Access Provider is not required to pay the Access Seeker for the preparation or use of, or access to, space provided pursuant to this sub-paragraph.
- 3.10 When provisioning a Service Request requiring new Duct build, the Access Provider is responsible for construction of the Duct on public land up until the demarcation point being the boundary of the plot where the Access Seeker Core Sites / Landing Station is located. The Access Seeker is responsible for construction of the lead-in Duct or in-building Duct or conduit from the demarcation point to the Access Seeker's Core Sites / Landing Station.
- 3.11 If the Access Provider's Equipment requires electricity supply and electricity connection points, they shall be supplied, in the location specified by the Access Provider, to the Access Seeker at the Access Seeker's expense according to the equipment specification. Such electricity shall be available at the same level of supply, protection and continuity as that available to the Access Seeker's Equipment, as appropriate.
- 3.12 The Access Seeker shall be solely responsible for any loss, theft or destruction of, or damage (reasonable wear and tear excepted) to the Access Provider's Equipment required to be located in the building where the CCLS Service is provided and which is within the control of the Access Seeker, occurring any time and howsoever caused (unless caused by the Access Provider or its agents).
- 3.13 The Access Seeker shall provide the Access Provider and any authorised employee, agent, affiliate or contractor of the Access Provider with all information and assistance that such person may reasonably require to design, test, commission and maintain the CCLS Service (which may include participation in testing procedures as and when reasonably requested by the Access Provider).
- 3.14 The Access Seeker may require their agent to be present during the installation, testing or commissioning done by the Access Provider but not so as to affect the Service Commencement Date.

Maintenance and Support

- 3.15 The Access Provider shall provide maintenance and support services in respect of the CCLS Service in accordance with the Schedule 7 – (Service Levels) of the Reference Offer and according to the processes set out in the CCLS Operations Manual.

Protection

- 3.16 The Access Seeker may procure a full geo-redundant link as protection. The geo-redundant link is considered as a separate CCLS Connection and charged at the applicable MRC representing a new CCLS Connection as set out in Schedule 3 of the Reference Offer. For the avoidance of doubt, the protection at core network level is not charged to the Access Seeker and it is only provided for information purposes and may be changed at the Access Provider's sole discretion.
- 3.17 The provision of the full geo-redundant link as protection is subject to availability, feasibility study and subject to the Access Seeker obtaining any relevant approval, including but not limited to access approvals, any relevant landlords and/or Government authority as long as the Access Provider made all reasonable efforts to obtain them, including making the relevant applications in a timely manner, notifying the Access Seeker of such requirement and keeping the Access Seeker updated on the progress.
- 3.18 During the provisioning of a CCLS Connection for which a full geo-redundant link as protection is required, the Access Provider shall provide the Access Seeker with the technical details regarding the protection solution, including the following:
- a. the service configuration;
 - b. the relevant acceptance tests for both the primary and secondary end-to-end CCLS Connections at RFS (after provisioning).

4. CHARGES

- 4.1 The Access Seeker shall pay to the Access Provider the relevant Charges determined in accordance with Schedule 3 – (Pricing) of the Reference Offer.
- 4.2 All Charges and sums due from one party to the other under this Agreement are exclusive of VAT. Any VAT shall be charged in accordance with the relevant regulation in force at the time of making the taxable supply and shall be paid by the paying party following receipt from the billing party of a valid VAT invoice.

5. SERVICE LEVELS

- 5.1 The Access Provider shall provide the CCLS Service in accordance with the Service Levels specified in Schedule 7 – (Service Levels) of the Reference Offer.

ANNEX 1 - CIRCUIT BANDWIDTH, DEFINED INTERFACES, MEDIA AND TOPOLOGY

Service element	Interface	Connector	Topology	Access
CCLS Connection terminating at Access Seeker Core Site / Landing Station	5G, OTU2/10G, 25G, OTU3/40G, 50G and OTU4/100G	SFP/XFP, LC/PC	Point-to-point	Fibre

The CCLS Service is provided in accordance with the ITU-T recommendation G.709

ANNEX 2 - PROVISIONING VALIDATION TEST

Provisioning Validation Test	
Testing Methodology	ITU-T G.709/ ITU-T Y.1564
Testing Mode	Testers simulates with setting of 5G, OTU2/10G, 25G, OTU3/40G, 50G and OTU4/100G levels of required Bandwidth and also tester simulates CPE.
Parameters tested	Frame loss, BERT, Throughput
Tester Setting	CCLS Bandwidth Variants
Test Results	Copy provided to the Access Seeker upon request at time of testing

ANNEX 3 - CCLS SERVICE DIAGRAMS

The diagrams below are simple representation of the Access Provider BNET Network used to deliver the CCLS Service.

CCLS Service between two Access Seeker's Core Sites

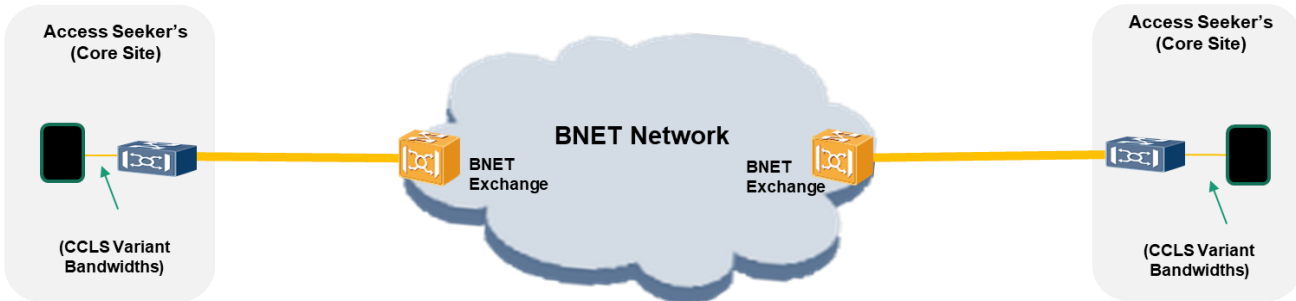

CCLS Service between Access Seeker's Core Site and Landing Station

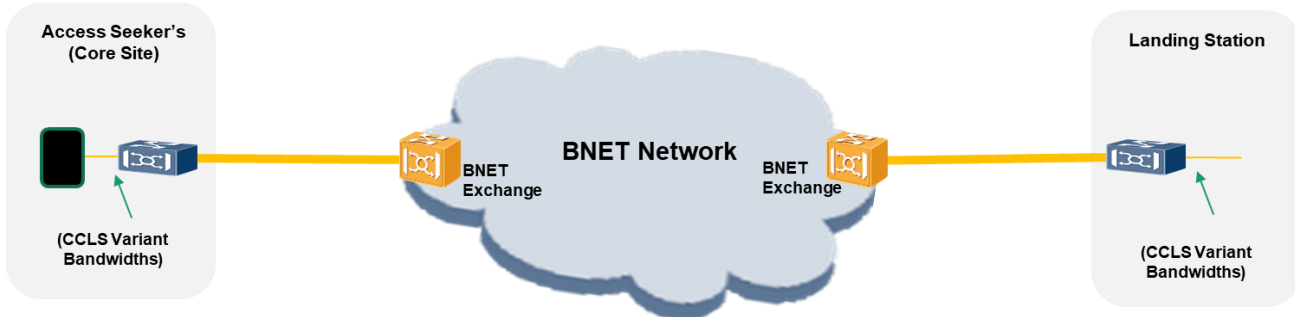

Core Layer (For information purposes only)

- BNET's network enhancement now enables Ethernet VPN (EVPN), allowing the deployment of traffic balancing and flexible deployment on Ethernet.
- The EVPN data is transported through Segment Routing over IPv6 (SRV6) technology on SRV6, ensuring that BNET's core network is able to provide the redundancy and protection required on multiple nodes in a single or multiple (GEO) physical sites.
- As such, this allows BNET to mitigate any single point of failure on its core network by allowing the traffic to be dynamically routed in case of any outage.

ANNEX 4 TO SCHEDULE 6.5

Core Connect and Landing Station Service (CCLS) Operations Manual

This document describes the onboarding, provisioning, fulfilment and fault handling process for the CCLS Service between the Access Provider and the Access Seeker. This document forms an integral part of the Access Provider's Reference Offer and of Schedule 6.5.

1. Onboarding

1.1 Onboarding Requirements

1.1.1 Access Seeker Onboarding

- (a) The Access Seeker shall review, acknowledge, and sign for Access Provider's counter signature the Supply Terms (Schedule 9) of the Reference Offer.
- (b) The Access Seeker shall have in force and maintain for the term of the Agreement a broad form of public liability insurance to the value of at least BD 250k and property insurance for the assets used in relation to this Agreement to the value of at least BD 100k.
- (c) These policies shall be with a licensed insurance company in the Kingdom of Bahrain and on terms and for coverage limited by only standard industry exclusions or exceptions.

1.1.2 Credit Security

- (a) The Access Seeker shall have in force and maintain security as requested by the Access Provider as required under the Reference Offer Supply Terms.

1.1.3 Licensing and Authorizations

- (a) The Access Seeker shall comply with the terms and conditions set out in the Reference Offer and relevant Service Descriptions, including obtaining any prior authorizations and shall maintain the required licenses as provided for by the Regulator.

1.1.4 Confidentiality and Non-Disclosure

- (a) The Access Seeker is required to execute the Access Provider's Non-Disclosure and Confidentiality Agreement and comply with any information protection.

1.1.5 BNET BSS

- (a) The Access Provider allows the Access Seeker to integrate via API to the Access Provider's BSS, which is designed based on the telecom standard framework for business process, the enhanced Telecom Operations Map ("eTOM") for placement of Service Order(s) and Service Request(s).

- (b) The Access Provider also provides an interface portal (the Access Provider Portal) for Access Seeker who do not have the capability to integrate via API. The Access Provider Portal is a standard Portal that may not provide the same enhancements and benefits that an Access Seeker would receive through API integration.
- (c) The Access Provider recommends access via API integration to its BSS.

1.1.6 Process for API Integration

- (a) If the Access Seeker opts for API integration, it shall contact the Access Provider Relationship Manager for API documentation.
- (b) Access Seeker will be required to undergo a trial phase for testing the API integration and will be required to sign off on the successful completion of the testing phase. Without limitation, the Access Seeker and Access Provider will confirm the following where applicable:
 - (i) The system integration has been completed;
 - (ii) The Access Seeker has portal access and credentials;
 - (iii) Network aggregation is implemented and tested;
 - (iv) A billing test on the relevant Service is confirmed; and
 - (v) Service provisioning of for the relevant Service is confirmed.
- (c) The Access Provider should ensure that all communications with the Access Seeker should be confidential and shall not be disclosed to other Licensed Operators.

2 Fulfillment

2.1 Request to Answer

- 2.1.1 The Request to Answer process is a pre-order management process. This process comprises of activities relevant to managing Access Seeker information requests across all communication channels (Access Seeker interfaces).
- 2.1.2 Specific information requests or product requests from the Access Seeker are qualified and addressed.
- 2.1.3 Pre-order Management consists of a set of functions across the API interface that enables the interaction before the Access Seeker order can be created.

2.2 CCLS Address & Service Availability Check

- 2.2.1 Prior to the Access Seeker placing a Service Order for the relevant Service, it is necessary to check whether the service infrastructure is available. The Access Seeker is provided with a tool to conduct varying levels of pre-qualification checks before submitting a Service Order.
- 2.2.2 In the circumstances where the Access Seeker chooses to submit a Service Order following the pre-qualification checks, the Access Provider shall verify the Service Order through an **Address Availability Check** – to identify whether the Access Seeker site address exists in the Access Provider Address database which is updated by the IGA (Information & eGovernment Authority) through their address database.

- 2.2.3 These qualification steps identify whether the Fulfilment request raised by the Access Seeker can be accepted. An Address Availability Check can be performed using the portal and the API integration and are performed by the Access Seeker.
- 2.2.4 The details of using the portal & API integration to interact with business processes mentioned in this Operational Manual are detailed in the LO API documentation shared by Access Provider.

2.3 CCLS Service Request

- 2.3.1 In the event neither the address nor the service availability check is successful, the Access Seeker may:
- (a) Where the address is not available on the Access Provider's database, raise a Service Request to add the address to the Access Provider's address database; and
 - (b) Raise a Service Request to provision the address with a CCLS Service based on the Access Provider's resources and availability.

2.4 Service Requests

- 2.4.1 If the Access Seeker opts for any of the options set out in paragraph 2.3.1 above, this shall be considered as a Service Request.
- 2.4.2 The Access Provider will, on a monthly basis, update the address list in the Access Provider Database which the Access Seeker shall be privy to if integrated through API or through access of the Portal. This information is provided by the IGA.
- 2.4.3 The Access Seeker is required to provide the information requested as per the form and mandatory fields set in the Portal/API in order to submit a Service Order. It is important for the Access Seeker to adhere to these mandatory fields, or otherwise may run the risk of having its Service Request rejected.
- 2.4.4 If Access Seeker finds that the address does not exist through the address availability check while raising the Service Order, the Access Seeker shall be eligible to raise a Service Request through the Portal or API for an address addition.
- 2.4.5 Every submitted Service Request will be allocated a unique identifier for tracking and managing the Request.
- 2.4.6 As part of the Service Request, the Access Seeker shall input the required information as per the below list, or in accordance with the required fields set out in the Portal/API:
- (a) Flat number– To be provided for address having flat number.
 - (b) Building number
 - (c) Street name
 - (d) Road Number
 - (e) Block Number
 - (f) City
 - (g) Area
 - (h) Country

- 2.4.7 The Access Seeker is required to attach mandatory End-User proof of address documents when raising a Service Request for address addition, such as a valid address card or any documentation which may be deemed as necessary by the IGA authority to validate the Access Seeker Core Sites/Landing Station.
- 2.4.8 The Access Seeker shall be responsible to ensure the validity, authenticity, and completeness of the above-mentioned attachments.
- 2.4.9 Where any of the documentation is considered as invalid, the Service Request shall be reassigned to the Access Seeker for rectification.
- 2.4.10 Where the address is validated by the IGA and accepted, such address will be updated in BNET database and the Service Request shall be closed. Whilst the address may be updated, this does not guarantee that the Service is covered. In this case, the Access Seeker may raise a Service Request for a cost assessment (please see refer to the process below on a cost assessment Service Request).
- 2.4.11 For the avoidance of doubt, if any of the above information requested as inputs from the Access Seeker have not been provided, the Service Levels in Schedule 7 of the Reference Offer will not be applicable.
- 2.4.12 The Access Seeker can issue a pre-order feasibility Service Request, which must contain the Service/product order details along with the requesting address.
- 2.4.13 The Access Seeker must verify the requesting address and the Service/product details (including but not limited to the Service/Product ID, Service feature requirements, i.e. committed bandwidth). These must be included in accordance with the mandatory fields in the Access Provider's Portal/API integration.
- 2.4.14 Upon receipt of the Service Request, the Access Provider will assess the Service Access Resources availability at the intended address location and will provide the status of Service provision in accordance with Schedule 7 of the Reference Offer.
- 2.4.15 Service Orders raised subsequent to Service Requests should refer the relevant pre-order feasibility Service Request(s).
- 2.4.16 For the avoidance of doubt, the Access Seeker's Service Request shall be rejected if:
- (a) it does not specify a valid address; or the address cannot be verified by the authority (IGA); or
 - (b) it does not provide the required inputs delineated above; or
 - (c) it does not have the authorizations provided for by its License to avail of the Service.
- 2.4.17 No service commitment or network resources reservation should be assumed to be done as a result of an unapproved cost assessment Service Request.

2.5 Order to Payment – Fulfilment of Service Orders

- 2.5.1 The Access Seeker may submit a New Connection ("New Provide") Service Order through API integration or via the Access Provider Portal.
- 2.5.2 The Access Provider will process these Service Orders as described below:
- (a) Service Orders will only be processed during the Access Provider's Working Hours.
 - (b) The Access Provider will acknowledge receipt of the Service Order within fifteen (15) minutes of receipt of the Service Order

- (c) For Service Orders submitted outside of Working Hours, the Access Provider shall acknowledge the Service Request within fifteen (15) minutes following the start of the first Working Hour after receipt of the Service Order.
- 2.5.3 A Service Order shall be considered invalid if:
- (a) it is incomplete or incorrect or illegible or cannot reasonably be understood;
 - (b) it does not properly identify the Access Seeker's Core Site/Landing Station;
 - (c) it is ordered to provision CCLS service for any End User;
 - (d) it resulted from a processing error.
- 2.5.4 The Access Provider shall, within two (2) Working Days, notify the Access Seeker if the Service Order is accepted or rejected and where applicable, state the required corrections. If a notification is not provided within two (2) Working Days of receipt of the relevant Service Order, the Service Order shall be deemed accepted by the Access Provider.
- 2.5.5 In the event a Service order is rejected then the Access Provider shall provide the Access Seeker with clear reasons for the rejection at the same time of the rejection and identify the changes required to enable the Service order to be accepted.
- 2.5.6 If the Access Seeker submits a Cancellation Request after three (3) or more Working Days from the Notification of Expected RFS Dates and where this is not related to delay in the Date or Actual RFS Date by the Access Provider, the Access Seeker shall (subject to receipt of an appropriate invoice) be liable to pay three (3) MRC to the Access Provider.
- 2.5.7 Within five (5) Working Days from the date of the acceptance of the Service Order, the Access Provider shall notify the RFS Dates to the Access Seeker, as specified in Schedule 7 – (Service Levels) of the Reference Offer. The Access Provider reserves the right to reject the Service Order during this stage if it is found that the CCLS Service is not supported or if the Access Provider's point to point Service Access Resources Network does not extend to the requested area within the Kingdom of Bahrain.
- 2.5.8 The Access Seeker shall book service installation initial appointment within 2 working days for service installation once RFS date is notified to Access Seeker. If the Access Provider's technician shall be present at the Access Seeker Core Site/Landing Station to install a CCLS Service, and if, for any reason, the Access Seeker cannot be available on the Expected RFS Date for such installation, the Access Seeker shall give the Access Provider a minimum written notice of one (1) Working Day. The revised Expected RFS dates are then set following the below principles.
- (a) The Access Seeker shall propose the next earliest date(s) for installation appointment which the Access Provider's technician would be available for the installation which shall be a maximum of two (2) Working Day notice from the day of the missed appointment.
 - (b) The previously notified Expected RFS Date is also modified and is set apart from the revised Expected RFS Date by the Maximum Validation Time of three (3) Working Days. The revised Maximum RFS Date is then set equal to the revised Expected RFS Date.
 - (c) The Access Provider shall send the Access Seeker a Notification of revised Expected RFS Date.

- 2.5.9 In addition, if at least one of the following two conditions is met (i) the Access Seeker does not provide the Access Provider a minimum written notice of two (2) Working Days to inform of its unavailability; or (ii) the Access Provider sends a technician who is not able to access the site to install the CCLS Service, then except for the cases of Force Majeure affecting the Access Seeker, the Access Seeker is liable to pay the installation and configuration charge for the requested CCLS Service as specified in Schedule 3 - (Pricing) of the Reference Offer. In such case, the modification and Notification of the revised Expected RFS Date and the revised Maximum RFS Date follow the same principles as described in paragraph 2.5.8.
- 2.5.10 The Access Provider's technician shall attend and access the Access Seeker Core Site/Landing during Working Hours and at least have called the Access Seeker's representative, if it appears that the Access Seeker's technician is not present at the relevant time (and where requested provide evidence of this). The Access Seeker shall, in this case, be liable to pay only the incurred man-day costs of the Access Provider technician.
- 2.5.11 In addition, if the Access Provider does not provide the Access Seeker with a written notice of a minimum of two (2) Working Days to rearrange a site visit under paragraph 2.5.10 above, then the Access Provider is liable to waive an amount equal to one installation and configuration charge for the CCLS Service.
- 2.5.12 Subject to the Access Seeker fulfilling its obligations set out in service description, the Access Provider shall provide, and the Access Seeker shall acquire the CCLS Service either within the standard timescales or by the Exceptional Delivery Date as appropriate.
- 2.5.13 Where the Access Provider has accepted a Service order which requires the deployment of Service Access Resources in a particular area, the Access Provider may also seek to recover the costs of such deployment through an NRC. Such instances shall be determined on an ad-hoc basis and include, but are not limited to, the following examples.
- 2.5.14 A Service Order shall be considered invalid if:
- (a) it is incomplete or incorrect or illegible or cannot reasonably be understood;
 - (b) it does not properly identify the Access Seeker Core Site/Landing Station;
 - (c) a valid written Access Seeker Core Network/Landing Station landlord consent cannot be produced by the Access Seeker to support the Service Order; and/or
 - (d) it resulted from a processing error.
- 2.5.15 At the time of rejection, the Access Provider shall provide sufficiently detailed written reasons for rejection to the Access Seeker.
- 2.5.16 The SLAs in schedule 7 shall only be applicable to forecasted Service Orders in line with Schedule 5 (Forecasting) of the Reference Offer.
- 2.5.17 A Service Order must be in the format notified by the Access Provider from time to time and be submitted through an online digital interface notified to the Access Seeker by the Access Provider, from time to time.
- 2.5.18 Only in the case where the online digital Portal or the API integration setup mechanisms are not accessible, electronic mails shall be accepted as a communication mechanism.
- 2.5.19 The Access Seeker's Billing Account must be active and not in a suspended state in order for the Access Provider to accept and proceed with the Service Order.

- 2.5.20 Access Seeker Core Network/Landing Station permissions & site readiness is the responsibility of Access Seeker to communicate to the Access Provider.
- 2.5.21 The time slots with regard to appointment rebooking will be made available to the Access Seeker two days from the date of initiating the re-booking of appointment.

Projects

- 2.5.22 For New Connections of more than fifteen (15) sites, the Access Seeker may request the Access Provider to consider such New Connections as one Project. Subject to agreement between the Access Seeker and Access Provider, the Project will be managed based on an agreed project plan between the Access Provider and Access Seeker.

2.6 Request to Change

- 2.6.1 In the event the Access Seeker elects to reschedule or cancel a Service Order past the point-of-no-return, the Access Seeker shall be charged rescheduling or cancellation charges in line with Schedule 3 (Pricing) if the rescheduling/cancellation request is made twenty-four (24) hours from the appointment date provided to the Access Seeker by the Access Provider. In such cases, the Service Levels set out in Schedule 7 shall be suspended until the appointment is booked.
- 2.6.2 The point of no-return shall be defined as the instance when the appointment date has been provided to the Access Seeker by the Access Provider, and prior to any visits made by the Access Provider to the Access Seeker Core Site/Landing Station.
- 2.6.3 To initiate a change to an existing CCLS Service used by the Access Seeker, the Access Seeker shall provide the Access Provider with a properly completed CCLS Change Request, in the format notified by the Access Provider from time to time, submitted by electronic mail (or other electronic format, which may include an online digital interface) to the address notified to the Access Seeker by the Access Provider, from time to time.
- 2.6.4 In addition to the rejection reasons set out at paragraph 2.5.7 the Access Provider may also reject a CCLS Change Request if it is not submitted in accordance with paragraph 2.5.14.
- 2.6.5 The Access Provider may, in its sole discretion, elect to accept any CCLS Change Request notwithstanding that there is any defect in that CCLS Change Request, if the Access Provider considers that such defect does not have a material effect on the Access Provider's ability to process the CCLS Change Request and provide the CCLS Service. A CCLS Change Request may comprise of any of the following:
- (a) External Relocation
 - (b) Internal Relocation
 - (c) Upgrade
 - (d) Downgrade

- 2.6.6 The Access Seeker shall submit the request to Access Provider for an internal relocation of the CCLS Service, which comprises of the relocation of an Access Provider's CPE inside the Access Seeker Core Site/Landing Station to another location within the same Access Seeker Core Site/Landing Station. The Access Provider shall charge a once off charge in accordance with Schedule 3 – (Pricing) of the Reference Offer for the internal relocation of the existing CCLS Service.
- 2.6.7 The Access Seeker shall send the request to the Access Provider for the external relocation or relocation of the CCLS service, which will follow the same process of SLA criteria as new connection.
- 2.6.8 The Access Seeker shall not be liable for any termination or additional recurring charges in respect of a request for a CCLS Amended Service which is for a relocation. The Access Provider shall charge a once off charge in accordance with Schedule 3 - (Pricing) of the Reference Offer for the relocation unless the Access Seeker requires both Connections to be operational in parallel. The Access Provider shall not terminate the Connection which is subject to relocation until the Service Commencement Date of the new Connection.
- 2.6.9 The Access Seeker shall be entitled to amend a CCLS Service by requesting a CCLS Amended Service where this is an Upgrade by providing an Upgrade Request to the Access Provider. The Access Seeker shall only be entitled to Downgrade the throughput of a Connection till the Minimum Service Period has expired. Where the Access Seeker requests a CCLS Amended Service, then the Service order procedure set out in this Service Description shall apply to that request. Where the Access Seeker requests a CCLS Amended Service that requires any new Network resources and/or facilities then a new Minimum Service Period shall commence and the Access Provider shall provide a CCLS Amended Service for the new Service Period.
- 2.6.10 The Access Seeker shall not be liable for any termination or additional recurring charges in respect of a request for a CCLS Amended Service which is for a relocation. The Access Provider shall charge a once off charge in accordance with Schedule 3 - (Pricing) of the Reference Offer for the relocation unless the Access Seeker requires both Connections to be operational in parallel. The Access Provider shall not terminate the Connection which is subject to relocation until the Service Commencement Date of the new Connection.
- 2.6.11 The Access Provider will provide an RFS Date with regard to an external relocation that is not within the Forecasted Orders and where the new intended address is not covered by Service Access Resources. For the avoidance of doubt, the SLAs in Schedule 7 will not apply to these Service Orders.
- 2.6.12 For any service upgrade that is not within the Access Seeker's forecasted Service Orders, the SLAs denoted in Schedule 7 will not apply, and the Access Provider shall provide an RFS Date based on network capacity availability.

2.7 Exceptions

- 2.7.1 The Access Provider shall, subject to the exceptions, limitations and conditions specified in this Service Description and/or Supply Terms, provision and deliver the CCLS Service on or before the RFS Date and in accordance with Schedule 7 - (Service Levels) of the Reference Offer.
- 2.7.2 The Parties acknowledge and accept that exceptional circumstances, such as those set out below, may give rise to delays in any stage of the provisioning and delivery of a Service Order. If the occurrence of any of the events below takes place, the Access Provider shall communicate the Exceptional Delivery Date to the Access Seeker and shall not be held liable for the Service Level Penalties. The exceptional circumstances shall only comprise of:
- (a) a Force Majeure Event or a Regulatory Event; or
 - (b) Emergency Maintenance; or
 - (c) any material breach of the Access Seeker's obligations.
 - (d) The Access Provider shall, in notifying the Access Seeker of the Revised Delivery Date, provide sufficient evidence to justify the reasons for the delay of the delivery.
- 2.7.3 The Access Provider shall not be obliged to further process a Service Order where:
- (a) the relevant CCLS Service cannot meet Service Qualification; or
 - (b) following the provision of reasonable notice by the Access Provider, an authorized person from the Access Seeker is not available to provide further information when requested.

2.8 Notification of Completion of Order

- 2.8.1 The Access Provider shall, on the same Working Day of completion of a Service Order, notify the Access Seeker of completion.
- 2.8.2 In the case of a Service Order, the Access Provider is entitled to rely on an evidence that the relevant Access Seeker's authorized person:
- (a) has given a valid Consent in relation to the requested Service Order; and
 - (b) in the case of a Change Request understands and has requested the Change.

2.9 Termination to Confirmation

- 2.9.1 Where the Minimum Service Period has not expired, the Access Seeker shall be entitled to terminate the CCLS Service on at least one (1) month's written notice to the Access Provider and shall be liable to pay liquidated damages as calculated by the following formula.
- 2.9.2 Formula for calculating liquidated damages: $LD = MRC \times (24 - M)$ where:
- LD = liquidated damages to be paid.
- MRC = Monthly Recurring Charge for the CCLS Service.
- M = number of months between the Actual RFS Date and the removal order date rounded-up to the next full month.

- 2.9.3 The Access Seeker shall not be liable to pay liquidated damages where the Access Seeker terminates the CCLS Service as a result of and/or arising out of a material breach of the Reference Offer by the Access Provider.
- 2.9.4 The Access Seeker expressly acknowledges that liquidated damages as calculated above form a reasonable pre-estimate of the loss which the Access Provider would suffer as a result of early termination by the Access Seeker. Such liquidated damages shall be the Access Provider's sole and exclusive damages or monetary remedy for such early termination.
- 2.9.5 Following the expiry of any Minimum Service Period the CCLS Service shall be automatically renewed for successive Renewed Minimum Service Periods unless and until terminated by the Access Seeker. During the Renewed Minimum Service Period, the Access Seeker may terminate the CCLS Service subject to providing the Access Provider with a written termination notice of at least one (1) month prior to the expiry of the Renewed Minimum Service Period. In the event that the Renewed Minimum Service Period expires, and the Access Seeker does not provide any written termination notice as above, the CCLS Service shall renew for a further Minimum Service Period.
- 2.9.6 The Access Provider may upon providing three (3) months' written notice to the Access Seeker and subject to the approval of the Regulator, vary the CCLS Service or withdraw the CCLS Service relating to the terms and Annexes in this Service Description, by issuing a revised Service Description.
- 2.9.7 Unless the Access Provider and Access Seeker agree otherwise at the time, any withdrawal or variation of the CCLS Service, or any amendment to the Charges payable for the CCLS Service in accordance with this Service Description and Schedule 3 – (Pricing) of the Reference Offer, shall also apply to existing CCLS Services provided under the Supply Terms, which shall continue in force in accordance with its terms and conditions until renewed or terminated in accordance with this Service Description or the Supply Terms

3 *Fault Handling and Resolution*

3.1 *Faults*

- 3.1.1 The Access Provider's responsibility for faults in the CCLS Service is limited to the following:
- (a) Any fault that affects the CCLS and/or in the Access Provider's Network, Systems, Access Provider Equipment where such fault is not caused, whether directly or indirectly, by the Access Seeker's actions or omissions;
 - (b) Any fault that the CCLS and/or in the Access Provider's Network, Systems, Access Provider Equipment where such fault is directly caused by the Access Provider's action or omission.
- 3.1.2 The Access Seeker is responsible for any fault that affects the CCLS and/or in the Access Provider's Network, Systems, Access Provider Equipment where such fault is caused, whether directly or indirectly, by the Access Seeker's actions or omissions, whether through negligence or otherwise.

- 3.1.3 The Access Seeker shall be responsible for providing an initial fault diagnosis and reporting for any fault reported to the Access Seeker by its End-Users. The Access Seeker must ensure that its fault reporting service is competent and sufficiently resourced as per the quality standards set in the industry.
- 3.1.4 Pursuant to paragraph 0 above and prior to notifying the Access Provider of a fault, the Access Seeker must:
- (a) Confirm the presence of a fault;
 - (b) Perform an initial fault diagnosis to identify where the fault has arisen;
 - (c) Use all reasonable endeavors to investigate the fault and find out all relevant information from its End-User;
 - (d) Confirm that the fault falls under the Access Provider's responsibility with a clear explanation as to why it considers this to be the case.
- 3.1.5 When the Access Seeker has met the conditions set out in paragraph 0 above, it must report any fault that the Access Provider falls under the Access Provider's responsibility, as set out in paragraph 3.1.1 above, to the Access Provider and provide reasonable information regarding the fault by raised a Customer Problem ticket.
- 3.1.6 If the fault is found to be outside of the Access Provider's responsibility, as set out in paragraph 3.1.1 above, or where the Access Provider cannot confirm the presence of a fault, the Access Provider may charge the Access Seeker on a time and materials basis.

3.2 Fault Resolution

- 3.2.1 The Access Seeker will facilitate contact with any relevant locations, such as Access Seeker Core Site or Landing Station and/or arrange a site visit this is reasonably required by the Access Provider to clarify the nature of, or undertake work to fix, any Reported Fault. the Access Provider may communicate with Access Seeker's authorized person directly so long as such communications are confined to technical matters directly concerning the Reported Fault.
- 3.2.2 Upon the Access Provider' acknowledgement of a Reported Fault that is the Access Provider' responsibility, the Access Provider will:
- (a) diagnose and fix the Reported Fault;
 - (b) following the initial diagnosis, provide an indication to the Access Seeker of the likely time to fix the Reported Fault (Response, provided that the Access Provider has no obligation to provide such indication if the Reported Fault is fixed at the time of initial diagnosis.

3.3 Reporting Faults to the Access Provider

- 3.3.1 The Access Provider has two automated channels which allows the Access Seeker to create customer trouble tickets:
- (a) Portal
 - (b) API Integration

- 3.3.2 The two channels allow Access Seekers to:
- (a) create a new trouble ticket;
 - (b) retrieve status and updates on a trouble ticket; and
 - (c) Receive ticket resolution and closure updated along with root cause.
- 3.3.3 Faults can be logged 24 hours a day, seven days a week.
- 3.3.4 The Access Seeker must use the Access Provider Portal or API Integration for reporting all faults regarding the CCLS Service. If the Access Seeker uses any other method to report a fault, the fault will not be acknowledged by the Access Provider or attended and the Service Levels as defined will not apply to that fault.
- 3.3.5 Where the Access Provider advises the Access Seeker that Portal /API is unavailable, the Access Seeker must submit fault reports to the Access Provider by calling the Access Provider Call Center. The Access Provider will use all reasonable endeavors to advise Access Seekers immediately upon becoming aware that the Portal /API is unavailable.
- 3.3.6 Once the Access Seeker has provided initial fault diagnosis, determined that it requires the Access Provider assistance to resolve the fault, the following information is required when reporting a fault:
- (a) confirmation that the initial fault diagnosis has been completed;
 - (b) contact name and phone number of the Access Seeker staff member logging the fault;
 - (c) CCLS Service Identifier for service that is experiencing the fault (where appropriate);
 - (d) fault type and description;
 - (e) time the fault occurred;
 - (f) address and contact details for the site of the fault (where appropriate); and
 - (g) any other relevant information.
- 3.3.7 If any of the above information set out from (a) to (h) in paragraph 3.3.6 above is not provided, the Service Levels in the Schedule 7 of the Access Provider Reference Offer will not apply.

3.4 Fault Report Acknowledgement

- 3.4.1 When a fault report is received, the Access Provider will advise the Access Seeker, acknowledging receipt of the fault report within specified SLA in schedule 7.

3.5 Fault Tracking

- 3.5.1 All faults will be logged in Portal /API integration and the Access Seeker will be given a fault reference number where the access seeker can get the update on the raised trouble tickets and the progress to restore the service.
- 3.5.2 Where the Access Provider subsequently becomes apparent that the fault restoration time cannot be met, the Access Provider will advise the Access Seeker of a revised fault restoration time.

3.6 Access Seeker Premises Visit

- 3.6.1 If the Access Provider identifies the need to send a field engineer to the Access Seeker site, the Access Provider will update Access Seeker trouble ticket in portal/API integration.
- 3.6.2 The Access Seeker's is responsible for coordinating site access, visit appointment and any required outage window with any relevant landlord.
- 3.6.3 In case the landlord does not respond to the Access Provider calls to confirm appointment, the KPI will be stopped and access seeker will need to re-book appointment and inform the Access Provider with new appointment booked.

3.7 Fault Types

- 3.7.1 If the issue can be fixed remotely, the Access Provider will fix the issue and the customer trouble tickets will be updated accordingly.
- 3.7.2 In the event where the issue is within passive or active resources, a planned outage will be required and the Access Provider will inform the access seeker on planning outage timings.
- 3.7.3 access seeker representative to be available at the time of the end-user visit to verify and accept the resolution of the end-user fault.

3.8 Fault Closure

- 3.8.1 Once the fault has been resolved, the Access Provider will notify the Access Seeker via Portal/API integration that the fault has been resolved, confirm the reference number and, where possible, provide the cause of the fault and any actions taken to reach resolution.

3.9 Emergency and Core Network Faults

- 3.9.1 Emergency and Core Network faults reported to the Access Provider will be treated on a case-by-case basis. In the first instance, the Access Provider will propose a temporary solution. However, in the absence of a viable temporary solution, the Access Provider may schedule a callout to respond to Core Network faults, or to emergency faults relating to mass outage that impacts an entire block or area.

4 Complaints

- 4.1 This section deals with Access Seeker enquiries where the Access Seeker is not satisfied with a product and/or handling and timeliness of an enquiry.
 - 4.1.1 Access Seekers can reach their designated account manager to report any complaint related to non-technical issues.
 - 4.1.2 Access seeker can raise their complaints through the portal and/or API integration.
 - 4.1.3 The Relationship Manager will acknowledge the receipt of the complaint within 2 working days.
 - 4.1.4 A response to the complaint will be provided to the Access Seeker within 5 working days.
 - 4.1.5 In case the Access Seeker finds the provided solution is not satisfactory, the complaint can be escalated to Head of relationship manager.

4.2 The Access Provider Network, the Access Provider Owned Equipment and Property.

4.2.1 For the Access Seeker's own safety, and so that services supplied by the Access Provider are not disrupted, the Access Seeker must help safeguard the Access Provider' Network and the Access Provider Owned Equipment. The Access Seeker must:

- (a) Follow the Access Provider' reasonable directions when connecting anything to the Access Provider' Network or any the Access Provider Owned Equipment
- (b) Only allow people authorised by the Access Provider to work on or around the Access Provider' Network or the Access Provider Owned Equipment; and
- (c) Make sure everyone the Access Seeker is responsible for also meets these obligations.

4.3 Access Seeker Responsibility towards the Access Provider Owned Equipment

4.3.1 At the time any the Access Provider Owned Equipment is supplied, the Access Provider will use all reasonable endeavours to make sure it is safe, durable and approved for connection to the rest of the Access Provider' Network.

4.3.2 Where the Access Provider supplies the Access Seeker with any the Access Provider Owned Equipment, the Access Seeker will, where applicable:

- (a) leave the Access Provider Owned Equipment installed and not use it otherwise than in specified in the service description.
- (b) protect the Access Provider Owned Equipment from radio or electrical interference, power fluctuations, abnormal environmental conditions, theft and any other risks of loss or damage.
- (c) if the Access Provider Owned Equipment is lost, stolen or damaged, notify the Access Provider directly and pay for repairing or replacing it, except where the loss, theft or damage was caused by the Access Provider;
- (d) follow the Access Provider' reasonable directions when using the Access Provider Owned Equipment and never use the Access Provider Owned Equipment for purposes for which it is not designed; and
- (e) not encumber the Access Provider' title to the Access Provider Owned Equipment or expose such title to third Party claims and notify the Access Provider if it becomes aware of any third-Party claim.

4.3.3 When any the Access Provider Owned Equipment is no longer required the Access Seeker:

- (a) must return the Access Provider Owned Equipment to the Access Provider;
- (b) will take reasonable care to avoid causing damage when returning the Access Provider Owned Equipment to the Access Provider and be responsible for any damage to the Access Provider Owned Equipment; and
- (c) must pay all Charges for the Access Provider Owned Equipment until such time as it is returned to the Access Provider.

5 Planned Outages and Maintenance

5.1 General Obligations

- 5.1.1 The Access Provider may suspend any CCLS Service in order to carry out Planned or Emergency Maintenance.
- 5.1.2 In the case of Planned Maintenance, the Access Provider shall use its best endeavors to carry such activity during the night or at weekends or other quiet periods.
- 5.1.3 The Access Provider shall give ten (10) Working Days' notice of each Planned Maintenance activity affecting a particular CCLS Service or group of CCLS Services. This shall include the circuits affected, the date and time of the suspension and the likely duration of the suspension.
- 5.1.4 The Access Provider shall give three (3) Days' notice of each Emergency Maintenance activity affecting a particular CCLS Service or group of CCLS Services. This shall include the circuits affected, the date and time of the suspension and the likely duration of the suspension.
- 5.1.5 In cases of Emergency Maintenance, the Access Provider shall advise the Access Seeker within five (5) hours after service is restored with a report of the cause of the Fault.
- 5.1.6 The Access Provider shall use its reasonable endeavors to take into account the reasonable operational concerns of the Access Seeker before implementing any Planned Maintenance and be carried in accordance with Schedule 7 of the Access Provider's Reference Offer.

5.2 Types of maintenance and support services

- 5.2.1 The Access Provider shall provide Network maintenance and support services, such as CPE replacement and Service Access Resources patch cord replacement, in accordance with the Service Levels set out in Schedule 7 - (Service Levels) of the Reference Offer. In the event that such replacement is required due to Access Seeker misuse, the Access Provider reserves the right to re-charge the replacement cost of these equipment(s) to the Access Seeker.

SCHEDULE 6.6 – SERVICE DESCRIPTION

SP-ACCESS SERVICE

1. SCOPE AND STRUCTURE

- 1.1 The Strategic Partner Access to Passive Infrastructure Process (SP-Access Service) hereby refers to a process following the Decision by the Authority to grant access over the Access Provider's Facilities to facilitate the provision of services to a designated Strategic Partner in the Kingdom of Bahrain.
- 1.2 The Access Seeker must adhere to the conditions of this Service Description with regard to a request made under the SP-Access to the extent to which it involves Passive Infrastructure (i.e., Fibre Cable pair to be provided on a rental basis for the use of the designated Strategic Partner). However, an Access Seeker, who is a holder of any telecommunications licence (whether Individual Telecommunications Licence or a Class Licence), shall be entitled to request use of Site Space and/ or Power under this Service Description, without this being for the provision of services to a designated Strategic Partner in the Kingdom of Bahrain.
- 1.3 The Access Provider shall implement an SP-Access Service only when it has received written confirmation of the Authority's approval to proceed Fibre Cable pair to be provided on a rental basis for the use of the designated Strategic Partner. For avoidance of doubts, the Authority's approval is not required for use of Site Space and/ or Power under this Service Description.
- 1.4 Both Access Provider and Access Seeker acknowledge and agree that the Authority's approval referred to in clause 1.3. above) is dependent on approvals from third parties including other Governmental department and, therefore, while the Authority will endeavour to provide such approval within 30 days of the Access Provider submitting the final implementation plan to the Authority as set out in this Schedule 6.6.
- 1.5 The Service
 - (a) The Strategic Partner Access Service to Passive Infrastructure (**SP-Access**) is service connecting a Strategic Partner Point of Presence and an Access Seeker Point of Presence through the Access Provider's Passive Infrastructure.
 - (b) Subject to clause 1.3 above, the SP-Access Service to Passive Infrastructure is available to any Access Seeker that has received a written, specific and verifiable request from a Strategic Partner for the provision of access to the Access Provider's Facilities in the manner set out in 3(b) below.
 - (c) Site Space and/ or Power can be used by any Access Seeker without this being for the provision of services to a designated Strategic Partner in the Kingdom of Bahrain.

2. DEFINITIONS

SP-Access or **SP Access Service** means the Strategic Partner Access Service involving use on a rental basis of a Fibre Pair and/ or Site Space/Power to be provided by the Access Provider to the Access Seeker.

SP-Access Service Commencement Date means the date of successful implementation and notified handover of the SP-Access Service by the Access Provider to the Access Seeker on the Access Delivery Date, which shall take place immediately following completion of testing as set out in the Reference Offer.

Facility means Passive Infrastructure, Site Space and/ or Power (whereas the Site Space and Power are described below in this Service Schedule).

Installation means the installation of an individual SP-Access Service as described in paragraph 1 of this Service Description.

Installation Charges means the Charges referred to as Make Ready and relevant installation Charges set out under the SP-ACCESS section of Schedule 3 - (Pricing) of the Reference Offer.

Minimum Service Period means a minimum period of twenty-four (24) or sixty (60) calendar months for which the SP-Access Service will be provided, such period commencing from the SP-Access Service Commencement Date.

Passive Infrastructure means a Fibre Pair.

Renewed Minimum Service Period means an applicable minimum period of one (1) month for which the SP-Access Service shall be provided, such period commencing from the expiry of a Service Period.

Strategic Partner means an entity designated by the Government of the Kingdom of Bahrain and confirmed by the Telecommunications Regulatory Authority as being a strategic partner of the Kingdom of Bahrain.

Service Period means the Minimum Service Period or Renewed Minimum Service Period.

3. LODGEMENT OF SP-ACCESS APPLICATION

- (a) The SP-Access shall be for the sole purpose of serving a Strategic Partner (as defined by the Authority) on an exceptional basis.
- (b) SP-Access Application, The Access Seeker must submit its SP-Access Application to both the Access Provider and the Authority. In addition to the information above, the Access Seeker must provide with its SP-Access Application substantiated evidence from the End User of the End User's request to the Access Seeker, that forms the basis for the Access Seeker's SP- Access Application. The Authority will acknowledge receipt of the Access Seeker's SP-Access Application to both the Access Provider and the Access Seeker within two (2) Working Days. Acknowledgement by the Authority of the Access Seeker's SP-Access Application shall result in the below timeframes for the Access Provider's processing of the Access Seeker's SP-Access Application being suspended. Unless the Authority notifies the Access Provider and Access Seeker that the Access Provider should not continue with processing the Access Seeker's SP- Access Application, the below timeframes shall recommence on the expiry of a period of five (5) Working Days from the date of the Authority's acknowledgment of receipt.

4. QUEUING POLICY

- (a) The Access Provider must develop and disclose to the Access Seeker a queuing policy for SP-Access Applications for the supply of access to a Facility within twenty-one (21) days of the date of the first request for a supply of access to a Facility from the Access Seeker or any other Licensed Operator.
- (b) The queuing policy must be consistent with the following principles:
 - (i) the queuing policy of the Access Provider must be non-discriminatory between Access Seekers;
 - (ii) the queuing policy also must apply on a non-discriminating basis to the provisioning of accepted SP-Access Applications and the Access Provider's own internal confirmed Facilities orders and/or those confirmed for other Licensed Operators.
 - (iii) subject to paragraph (i) above, the Access Provider must seek to maximise the efficiency of its queuing policy.
- (c) The Access Provider must, within five (5) Working Days of receipt of a SP-Access Application notify the Access Seeker of its receipt and its place in the queue.
- (d) The Access Seeker may prescribe the order in which simultaneous applications by it with the Access Provider should be treated in a queue.

5. ASSESSMENT OF SP-ACCESS APPLICATION

- (a) The Access Provider must notify the Access Seeker:
 - (i) within **(5) five Working Days** of receiving the SP-Access Application, if it requires more information in relation to the SP-Access Application, in which case the time period under paragraph (c) below can be extended by the number of Working Days it takes for the Access Seeker to provide the information;
 - (ii) within **(10) ten Working Days** of receiving the SP-Access Application, if it requires a modification to the SP-Access Application, in which case the Access Provider must provide at that time its proposed modifications.
- (b) If the Access Provider requests modifications to the SP-Access Application in accordance with paragraph (a)(ii) above, the Access Seeker must, within (5) five Working Days of receipt of that request, give consideration to those modifications and accept the modifications or notify the Access Provider that it does not agree with the proposed modifications. If the Access Seeker does not agree with the proposed modifications, the Access Seeker may withdraw its SP-Access Application or request a meeting with the Access Provider within (10) ten Working Days of the notification to the Access Provider that it does not agree with the proposed modifications. Following this meeting, if the parties cannot agree on modifications, then the matter will be resolved under the Dispute Resolution Procedures.
- (c) The Access Provider will provide to the Authority a copy of all documentation collected by the Access Provider from the Access Seeker up to this stage in the process.

- (d) Subject to any extension of this timeframe under paragraphs 5(a) or (b), the Access Provider must notify the Access Seeker, within the time period specified in paragraph 5(d) from receipt of the SP-Access Application, whether:
 - (i) it accepts the SP-Access Application and whether it wishes to carry out a Field Study under paragraph 7 prior to granting the Access Seeker the right to issue a Service Request in respect of the Facility under paragraph 8; or
 - (ii) it will reject the SP-Access Application, in which case a Service Request cannot be issued in respect of the Facility by the Access Seeker and access to the Facility will not be granted to the Access Seeker.
- (e) The Access Provider must conduct a Field Study under paragraph 5(c)(i).
- (f) The time period specified is thirty (30) Working Days or such other time as is agreed.
- (g) Failure to give notice under paragraph (c) will be deemed to be a proposed rejection of the SP-Access Application by the Access Provider. If the Access Seeker continues to require access, the Access Seeker must request the Access Provider to confirm the deemed proposed rejection within five (5) Working Days from the date of the deemed proposed rejection, and, if so requested, the Access Provider must accept or confirm that it proposes to reject the SP-Access Application within a further (5) five Working Days. The timeframe in paragraph 5(b) will be extended by the period it takes the Access Provider to confirm its proposed rejection in accordance with this paragraph.
- (h) Where the Access Provider proposes not to accept an Access Seeker's SP-Access Application, the Access Provider shall first communicate this to the Authority. The timeline for issuing a rejection shall be suspended for a period of (5) five Working Days to enable the Authority to provide its comments regarding the proposed rejection.

6. REJECTION OF A SP-ACCESS APPLICATION

- (a) A SP-Access Application may be rejected for the following reasons:
 - (i) the provision of SP Access Service would prevent the Access Provider from fulfilling its legal obligations, including national interest, law and order or defence obligations;
 - (ii) a purpose for which access to the Facility is sought is not the purpose of installing, operating and maintaining Equipment used or designed for use in connection with the supply of services in accordance with the terms of the Access Seeker's Telecommunications Licence;
 - (iii) the Access Seeker has not given the Access Provider reasonable notice in respect of when the Access Seeker wishes to obtain access to the Facility;
 - (iv) access to the Facility is not technically feasible;
 - (v) the Access Provider is not legally required to provide Access Services;
 - (vi) the Access Provider determines in its unfettered discretion that the Equipment which the Access Seeker proposes to install at the Facility does not meet the Access Provider's required technical standards and quality;
 - (vii) Currently Planned Requirements in relation to the Facility prevents the Access Provider from providing access to the Facility; or

- (viii) the SP-Access Application relates to a Facility where an existing user has commenced preparatory conduct (**Preparatory Conduct**), and the provision of access to the Access Seeker would prevent the existing user's intended use of the Facility (**Intended Use**) and for the purposes of this paragraph, the existing user has commenced Preparatory Conduct where it has commenced provisioning or providing capacity in or on the Facility for an Intended Use, including by:
- 1 entering into a contract with a customer in relation to the Intended Use of the Facility, including for a particular event or purpose;
 - 2 obtaining landlord, local or state government approval where such approval is necessary for the Intended Use of the Facility;
 - 3 applying to the Authority for a frequency licence in respect of the operation of particular Equipment where such a licence is necessary for the Intended Use of the Facility;
 - 4 entering into a contract for the installation of Equipment, or requesting tenders in respect of such a contract, or commencing ordering and/or installing Equipment for the Intended Use of the Facility; or where the existing user is a Licensed Operator, obtaining the Access Provider's written acceptance of its SP-Access Application for its Intended Use.
- (b) If the Access Provider proposes to reject the SP-Access Application of the Access Seeker under paragraph 5(c), it must provide the Access Seeker with a written explanation of its reasons and, if requested by the Access Seeker, meet within (10) ten Working Days of receiving the application to discuss those reasons. The parties will use reasonable endeavours to develop a strategy for managing access to the Facility or an alternative Facility which addresses the reasonable concerns of each party but in the absence of agreement, the Access Provider may reject the SP-Access Application.
- (c) Where an application has been rejected by the Access Provider for technical reasons under paragraph 6(a)(iv), the Access Seeker is entitled to resubmit an amended application at any time, and the proposal must be reconsidered in accordance with this Service Description.

7. CONDUCT OF FIELD STUDY

- (a) Where the Access Provider reasonably determines that a Field Study is necessary to determine whether the relevant Facility is available for access, the Access Provider must notify the Access Seeker of such determination at the time it notifies the Access Seeker of its acceptance of the SP-Access Application under paragraph 5(c) and that the granting of access in respect of the accepted SP-Access Application subject to the successful completion of that Field Study.
- (b) Where the Access Provider elects to conduct a Field Study under paragraph 6(a), it must complete such Field Study within (30) thirty Working Days of notification of its intentions to the Access Seeker under paragraph 5(c) (**Field Study Timeframe**), and within the Field Study Timeframe, the Access Provider must inform the Access Seeker of the following:

- (i) whether the Access Provider is offering the Access Seeker the right to issue a Service Request in respect of that Facility under paragraph 8;
 - (ii) confirmation of the results of any preliminary assessment of access or details and explanation of any variation to the results of a preliminary assessment of access;
 - (iii) details of the Make Ready Work required (including who will be responsible for undertaking each part) and the time required to perform the Make Ready Work;
 - (iv) the estimated Access Charges, estimated Make Ready Work costs and other costs of obtaining access;
 - (v) the time required to deliver access, after a Service Request for access has been made by the Access Seeker;
 - (vi) the Facility's security classification for physical access purposes; and
 - (vii) other matters as determined by the Access Provider from time to time.
- (c) If the Access Provider considers that it is unable to complete the Field Study within the Field Study Timeframe, the Access Provider must notify the Access Seeker that an extension of the Field Study Timeframe is necessary and the anticipated duration of that extension. Such notice is to be given prior to the expiry of the Field Study Timeframe (or the extension of the Field Study Timeframe, as the case may be).
- (d) Where the Access Provider is required by law to provide Access Services, it shall estimate its Make Ready Work costs in accordance with a schedule of costs for time and materials set out in Schedule 3 – (Pricing) of the Reference Offer.
- (e) Upon reasonable notice to the Access Provider, the Access Seeker shall have the right either to supply to the Access Provider its own materials of the same, or materially the same, type and quality as the Access Provider's materials detailed in the Field Study for use in any Make Ready Work or, where reasonably practicable, to carry out the whole or any part of the Make Ready Work itself as a sub-contractor to the Access Provider subject to fair and reasonable terms and conditions for the provision of that sub-contracted Make Ready Work.
- (f) The Access Provider must provide to the Authority a copy of all the materials collected through the processes outlined in paragraph 7(b) to (e) inclusive, for the Authority's review. The Authority will endeavor to provide a decision including any necessary approvals within one (1) month. The timelines for the Access Provider's processing a Service Request for the Access Seeker's SP-Access Application will be suspended until the Authority advises the parties of its decision. The Authority will endeavor to communicate its decision and/or any necessary approvals within one (1) month from receipt of the materials.

8. SERVICE REQUEST FOR ACCESS TO FACILITY

- (a) Where the Access Provider has notified the Access Seeker under paragraph 7(b) that it is offering the Access Seeker the right to issue a Service Request in respect of a Facility and if the Access Seeker wishes to lodge a Service Request for access to a Facility, it must do so within **(30) thirty Working Days** of being so advised by the Access Provider.

- (b) A Service Request must be consistent with the Equipment, plant, work, costs and charge details specified in the Field Study. If the Access Provider determines that a Service Request, in whole or part, is inconsistent with the relevant Field Study, the Access Seeker must rectify any deficiencies within **(2) two Working Days** of being notified of such deficiencies by the Access Provider.
- (c) The Service Request must be in writing and specify:
 - (i) the term of access requested;
 - (ii) any reasonable written instructions applicable to the installation of Equipment;
 - (iii) a description of the Equipment to be installed by the Access Seeker and a description of the Facility; and
 - (iv) the required delivery date and physical arrangements for access to the Facility and the Equipment to be installed by the Access Seeker.
- (d) The Access Provider must give written acknowledgment of the receipt of that Service Request and provide a response within (10) ten Working Days of receipt. The response shall specify:
 - (i) details of Make Ready Work;
 - (ii) the applicable Charges;
 - (iii) the description of the Facility to which access is sought and the Equipment to be installed by the Access Seeker;
 - (iv) the date upon which access will be provided (**Advised Delivery Date**); and
 - (v) any instructions applicable to the Equipment to be installed by the Access Seeker.
- (e) If the Access Seeker cancels or varies a Service Request between the date of acceptance and the Advised Delivery Date, the Access Seeker must pay the amount of any loss suffered by the Access Provider. In this paragraph, "loss" means:
 - (i) the costs which have been reasonably incurred by the Access Provider on the basis of the Service Request and which will not be otherwise reimbursed following the cancellation of the Service Request; and
 - (ii) the costs of capital relating to the holding of Equipment or space on the Facility until use, disposal or reuse, and any costs reasonably incurred in arranging for such use, disposal or reuse.

9. GRANTING OF ACCESS

- (a) If the Access Provider accepts a Service Request in respect of a Facility, the Access Provider must:
 - (i) continue, where relevant, to hold the Facility Lease for the Facility and will be the sole lessee under the Facility Lease and the Access Seeker must not object to the continuation of any existing Facility Sub-Leases already granted in respect of the Facility; and
 - (ii) grant to the Access Seeker a Facility Sub-Lease of an agreed part of the Facility to enable the Access Seeker to install, use and maintain its Equipment on the Facility;
- (b) Unless the Access Seeker agrees otherwise, the term of the Facility Sub-Lease will be as specified in the Facility Sub-Lease.

- (c) Where the Access Provider owns the existing Facility, the term of the Facility Lease will be as specified in the Facility Lease.
- (d) In relation to the Access Provider accepting a Service Request in respect of a Radio-communications Site only, the Access Provider must continue to own any Towers on a Radiocommunications Site which is to be a Shared Facility.
- (e) The parties will endeavour to ensure that a Facility Lease or Facility Sub-Lease is executed before any Make Ready Work commences. The Access Provider must prepare the draft Lease or Sub-Lease as the case may be. Where at the time of access to the Facility a formal Facility Lease or Facility Sub-Lease has not been executed, the Access Seeker will be deemed to be bound by the terms and obligations of the proposed Facility Lease or Facility Sub-Lease at the material time.

10. RULES FOR SYNCHRONISATION OF THE FACILITY SUB-LEASE TERMS WITH THE HEAD LEASE TERM

10.1 The following rules will apply in synchronising the Facility Sub-Lease terms with the term of the head lease:

- (a) each Facility Sub-Lease must expire one day before the head lease out of which it is granted;
- (b) each Facility Sub-Lease must only be supported by one head lease term;
- (c) the commencement date of the first Facility Sub-Lease term (which will be the earlier of the date of execution of the Facility Sub-Lease or the date of delivery of possession) will be the same date of the month as the date of the month that the supporting head lease commenced, irrespective of the day in the month that delivery of possession occurs under the Facility Sub- Lease;
- (d) the initial Ongoing Access Fee of the Facility Sub-Lease commences from the commencement date stated in the Facility Sub-Lease and not the subsequent date of the delivery of possession; and
- (e) if the Access Provider has entered into sequential head leases in respect of a site, or one head lease with sequential terms, the Access Seeker shall have the right to enter into sequential subleases or one sublease with sequential terms, each sublease to comply with paragraphs (a) to (d) above in respect of the relevant head lease. Nothing in this paragraph shall constrain the Access Provider's ability to terminate any head lease, or give notice to the Lessor that any head lease will not commence, or give notice to the Lessor that any further term of a head lease will not commence.

11. POWER

- a. Unless otherwise agreed, and to the extent permitted by the relevant authority, the Access Seeker must make its own arrangements for electric power (**Power**) at its own cost, including, but not limited to, its own Power main, Power feed, Power meter or meters and associated Power infrastructure (**Power Supply**).
- b. In the event that the relevant authority under paragraph (a) is not prepared to provide the Access Seeker with a separate Power feed in respect of the Facility, the Access Provider will, where practicable, permit the Access Seeker to share the Power Supply in return for a reasonable increase

in the Charges payable, calculated reasonably by the Access Provider at the time that the request to share the Power Supply is made, by reference to the cost at which the Access Provider is supplied the Power. The Access Seeker will pay all costs, expenses and charges incurred by reason of establishing the Power Supply as a shared Power Supply.

12. PERMITS AND APPROVALS

12.1 Access Seeker's responsibility

If it is necessary to obtain permits, approvals or licences required from any governmental, regulatory or public authority, agency or body (**Third Party Regulatory Approvals**) in relation to any Make Ready Work or the installation, repair, testing, operation, maintenance or removal of Equipment, the Access Seeker must use its reasonable endeavours to obtain the Third Party Regulatory Approvals, and will bear the cost of obtaining those Third Party Regulatory Approvals, unless the relevant law or government regulation requires that the Access Provider obtains it, in which case the Access Provider must use its reasonable endeavours to do so, but at the Access Seeker's expense.

12.2 Co-operation

Each party will provide all co-operation that the other party reasonably requires to obtain any approvals under paragraph 12.1 and must do so in a timely fashion and in a manner consistent with its own operations. If any approvals cannot be obtained, the parties must not carry out the activity for which approval has been refused.

13. PERFORMANCE OF MAKE READY WORK

(a) The Access Provider will:

- (i) take all reasonable steps to ensure that all Make Ready Work is carried out so far as practicable, within the construction timetable and cost estimates forming part of the Field Study; and
- (ii) notify the Access Seeker of any delays which it anticipates as soon as practicable after becoming aware that such delays may occur.

(b) If, after the commencement of Make Ready Work, the Access Provider determines that the actual cost of carrying out the Make Ready Work is likely to exceed, by more than 15%, the Make Ready Work costs specified in the response to the Service Request:

- (i) the Access Provider may immediately suspend all Make Ready Work and advise the Access Seeker accordingly;
- (ii) as soon as practicable, the Access Provider must provide a "**Work Variation Report**" to the Access Seeker setting out the nature and extent of additional Make Ready Work, revised Make Ready Work costs and any revised Advised Delivery Date; and
- (iii) upon receipt of a Work Variation Report, the Access Seeker must either request the Access Provider to carry out the Make Ready Work at the revised Make Ready Work costs (and/or by the revised Advised Delivery Date) or inform the Access Provider that it does not wish to

proceed with the Make Ready Work. In regard to the latter, the Access Seeker must pay Make Ready Work costs to the extent then incurred by the Access Provider.

- (c) The Access Provider will not incur any penalty or liability to the Access Seeker by reason of any suspension of Make Ready Work pursuant to this paragraph and the Advised Delivery Date will, to the extent required, be adjusted to take into account the additions to, or variations in, Make Ready Work.
- (d) The parties agree that in addition to the Make Ready Work costs specified in the response to the Service Request, the Access Seeker will bear any additional Make Ready Work costs which do not exceed 15% of the estimated Make Ready Work costs.

14. DELIVERY OF ACCESS

- (a) Prior to the delivery of access to the Facility, the Access Provider must perform all Make Ready Work which it has agreed to perform, and perform that work as soon as reasonably practicable.
- (b) After it completes the Make Ready Work, the Access Provider must notify the Access Seeker of the Advised Delivery Date, which may be different to that specified in the response to the Service Request.
- (c) The Access Provider is not obliged to deliver access on the Advised Delivery Date if Make Ready Work cannot be reasonably completed, due to unforeseen circumstances or circumstances beyond the Access Provider's control before that date, and notice has been given to the Access Seeker, in which case access will be delivered as soon as reasonably practicable after the Advised Delivery Date.
- (d) The Access Provider may depart from the Field Study provided that the variation does not have a material impact on the Access Seeker's use of Equipment or cost. Where any such variations are likely to have a material impact on the Access Seeker's use of Equipment, the Access Provider must give prior notice to the Access Seeker in respect of such material impact.
- (e) The Access Seeker must deliver to the Access Provider all plant and Equipment of the Access Seeker to be installed by the Access Provider in a timely manner which allows the Access Provider to comply with all timeframes in the Field Study.
- (f) Subject to paragraph (g), the Access Seeker must install and test its Equipment in accordance with the work plan included in its SP-Access Application and within three (3) months of the completion of Make Ready Work. The Access Seeker will be responsible for the testing of its Equipment. The Access Provider, at the Access Seeker's cost, may provide any reasonable assistance required for such testing.
- (g) The Access Seeker must contract with the Access Provider for the installation of equipment on any Facility which is a Tower on a time and materials basis.

15. COMPLETION INSPECTION

- a. Unless the parties otherwise agree, upon completion of installation work by the Access Seeker, there must be a joint on-site inspection between the Access Provider and Access Seeker to ensure that Make Ready Work and installation work have been satisfactorily completed and to agree whether access and installed Equipment have been provided in accordance with the details of the approved SP-Access Application.
- b. The scope of the completion inspection is to be agreed by the parties.
- c. If the Make Ready Work and Equipment installation have not been satisfactorily completed, the parties must agree what remedial work is required and carry out that remedial work. Following completion of any remedial work, the parties must hold a further meeting to confirm the satisfactory completion of the Make Ready Work and Equipment installation. The remedial Make Ready Work (but not the Equipment installation) will only be performed by and/or at any cost to the Access Provider if such work is required because the Access Provider has not performed Make Ready Work specified in the Field Study.

16. MAINTENANCE, EQUIPMENT REPLACEMENT AND INTERFERENCE

16.1 General principles

- (a) Each party is responsible for the maintenance and safe operation of its Equipment, provided that the Access Seeker must contract with the Access Provider for the Access Provider to perform all maintenance of any Equipment which is located on a Facility which is a Tower.
- (b) The Access Provider is responsible for maintaining each Shared Facility in a safe and operable condition and must, within a reasonable time of a request by the Access Seeker that it do so, provide satisfactory evidence of certification of all reasonable or necessary maintenance and safety checks and inspections.

16.2 Facility and equipment protection

Each party must take all reasonable and necessary steps to ensure that its Equipment does not:

- (a) endanger the safety or health of the officers, employees, contractors or agents or customers of the other party; or
- (b) damage, interfere with or cause any deterioration in the operation of the other party's Facility or Equipment.

16.3 Co-ordination of maintenance

The parties recognise that maintenance of one party's Equipment in a Shared Facility may unavoidably require Outages to another party's Equipment. The parties intend that any maintenance work in such Shared Facility should be planned to cause minimum disruption to each party's services. To this end, the parties will comply with the procedures for coordinated scheduling of maintenance of their respective Equipment as set out in this paragraph.

16.4 Access windows

The Access Provider will, following consultation with the Access Seeker, schedule Access Windows within which the parties will undertake their regularly scheduled work on the Equipment and, in the case

of the Access Provider, the Shared Facility. Access Windows must be scheduled in accordance with the principle that they are to occur at a time when each party's Equipment is carrying the least traffic but also at a time when it is reasonably practical to perform maintenance work and provide the required access. Any installation work required, or switch offs should be performed within the Access Windows. Unless otherwise agreed, the Access Seeker must negotiate any switch offs of any Equipment of a third party necessary as a result of the installation or maintenance of the Access Seeker's Equipment, with that third party.

16.5 Unscheduled maintenance

The parties will comply with the procedures in paragraph 16.6(a) in respect of the performance of any unscheduled maintenance by a party outside an Access Window. As a general principle, if the parties agree that maintenance work can be reasonably delayed until the next Access Window, then it should be delayed.

16.6 Emergency procedures

- (a) For the purposes of the Access Provider undertaking Emergency Work in relation to a Shared Facility, if the Equipment of the Access Seeker has to be turned off or turned down or the Access Provider requires assistance in relation to the Access Seeker's Equipment, the Access Provider will notify the Access Seeker and the Access Seeker will dispatch personnel on an emergency basis to the Shared Facility in accordance with the same procedures and timeframes as the Access Seeker would respond to an emergency relating to its own Equipment at that Shared Facility.
- (b) If the Access Provider becomes aware of a fault, defect or problem with the Access Seeker's Equipment or other facilities located in a Shared Facility which causes, or there is a reasonable risk that it might cause, damage to the Shared Facility or to either party's Equipment, the Access Provider:
 - (i) must notify the other party as soon as practicable; and
 - (ii) where there is an immediate risk of personal injury or significant property damage (including to the other party's or third party's Equipment), may take interim measures reasonably necessary in relation to the other party's Equipment to prevent such injury or damage, pending the attendance by the other party's personnel to perform the required corrective work.

16.7 Relocation

- (a) Once the location of the Access Seeker's Equipment on a Shared Facility has been determined, and any part of it is installed, the Access Provider may only with the consent of the Access Seeker (such consent not to be unreasonably withheld), require that it be relocated elsewhere upon that Facility.
- (b) The Access Seeker is not required to consent to the relocation of its Equipment unless:
 - (i) the Access Provider pays the reasonable cost of such relocation; and
 - (ii) the proposed new location of the Access Seeker's Equipment does not result in a material reduction of amenity (including technical, operational and maintenance capability) in the use of that Equipment.

16.8 Replacement of equipment

- (a) On giving **ten (10) Working Days'** prior written notice to the Access Provider, the Access Seeker may replace Equipment currently located in a Shared Facility with similar or new design Equipment or other facilities if all of the conditions in paragraph 16.8 (b)(i) to (v) are satisfied, unless the parties have agreed otherwise in a SP-Access Application.
- (b) The Access Provider agrees (such agreement not to be unreasonably withheld) that any replacement Equipment will not result in or cause:
 - (i) significant difficulties of a technical or engineering nature;
 - (ii) significant interference with the delivery of telecommunications services supplied by the parties or other Licensed Operators;
 - (iii) significant additional space requirements;
 - (iv) significant interference with any Equipment of the parties or third parties located at or in the Shared Facility such that the performance level of the Equipment or Facility falls below the Access Provider's standards in the case of the Access Provider's Equipment or below accepted industry standards in the case of all other Equipment; or
 - (v) a significant threat to the health or safety of persons who operate, or work on, or are near, the Shared Facility.
- (c) The replacement work must take place within an Access Window or some other time agreed to by the parties and all third parties which share that Facility.
- (d) The Access Seeker must contract with the Access Provider for the replacement of Equipment at any Facility which is a Tower.

16.9 Additional equipment

The Access Seeker may only install Additional Equipment in a Shared Facility by submitting and gaining approval of a SP-Access Application in accordance with this Service Description.

16.10 Interference

- (a) Neither party must do anything, or knowingly permit any third party to do anything, in a Shared Facility which causes interference which materially obstructs, interrupts or impedes the continuous use or operation of the Equipment of the parties installed in the Facility, or a third party's Equipment.
- (b) In the event of one party advising the other of any interference allegedly caused by a breach by that party of paragraph (a), subject to paragraphs (d) and (e), that party must expeditiously remedy such a breach.
- (c) In addition to the obligations under paragraph (b), if the advice of any interference is given within one week of:
 - (i) the other party installing new or additional Equipment; or
 - (ii) the other party commissioning new or additional Equipment, then that other party must remedy that breach as soon as possible and, in any event, within (24) twenty-four hours.
- (d) If, within forty-eight (48) hours after receiving notification of the interference, a party is not able to reasonably demonstrate that the interference is not being caused by that party's use of the Shared Facility, the parties will appoint an independent expert (and, in the absence of such agreement, an expert appointed by the president of the Bahrain branch of the Institute of Electrical Engineers or if

- that is not possible, another independent engineering association in the Gulf region nominated by the Access Provider) to determine the cause of the interference and, if caused by either party, how the interference is to be eliminated. The independent expert must make that determination within seventy-two (72) hours of being appointed unless otherwise agreed. The parties agree to provide the independent expert with all information within their control and relevant to the interference.
- (e) Subject to paragraph (g), if the determination of the independent expert is that the Access Seeker is causing the interference and that to eliminate such interference requires removing, relocating or modifying the Access Seeker's Equipment, the Access Seeker must do so within 48 hours of the independent expert notifying the parties of its determination and the Access Seeker must bear all costs of this work.
 - (f) Subject to paragraph (g), if the determination of the independent expert is that the Access Provider's Equipment is causing the interference, the Access Provider will use all reasonable endeavours to eliminate such interference and where the Access Provider is unable to eliminate such interference, the Access Provider may require the Access Seeker to remove, relocate or modify the Access Seeker's Equipment and the Access Provider will bear all reasonable costs of the Access Seeker in complying with any such requirement.
 - (g) The Access Provider will, at the expense of the Access Seeker, accept a surrender or a variation of the Facility Lease or Facility Sub-Lease if such surrender or variation is reasonably required as a result of the determination of the independent expert and the Access Provider will pay the Access Seeker a pro rata refund to cover unused amounts paid in advance to the Access Provider less any amount in respect of any loss suffered by the Access Provider from such surrender or variation of the Facility Lease or Facility Sub-Lease. In this paragraph, "loss" means:
 - (i) the costs which have been reasonably incurred by the Access Provider which will not be otherwise reimbursed following the surrender or a variation of the Facility Lease or Facility Sub-Lease; and
 - (ii) the costs of capital relating to the holding of Equipment or space on the Facility until use, disposal or reuse, and any costs reasonably incurred in arranging for such use, disposal or reuse.

The parties agree that any charges imposed by the Access Provider under this paragraph represent a genuine pre-estimate of the loss the Access Provider will suffer and are not a penalty.

16.11 Third party equipment

- (a) Subject to paragraph (b), the Access Provider may agree to a third party installing Equipment in a Shared Facility, provided that the third party's Equipment does not interfere in a material way with any of the Access Seeker's Equipment. The Access Provider must otherwise consult with the Access Seeker.
- (b) The Access Provider may without notice to the Access Provider agree to any governmental, regulatory or public authority, agency or body installing any equipment of any kind in a Shared Facility for the provision of emergency services, national defence or any other public service and the Access Provider shall not in any way be liable to the Access Seeker for any interference which

such equipment may cause to the Access Seeker's Equipment and the Access Seeker must do all things necessary to ensure that the Access Seeker's Equipment do not in any way interfere with such equipment.

- (c) The Access Seeker will not be responsible for the costs of installing third party Equipment, or installation and maintenance of the third party Equipment.
- (d) The Access Provider will use all reasonable endeavours to make it a condition of giving permission to a third party to install its Equipment in the Shared Facility, that the third party agrees to comply with terms consistent with paragraph 16.10 in relation to the third party's use of the Shared Facility and further to include suitable indemnities by the third party against damage to persons or property affording protection for liability or loss to all persons who share the Facility. The Access Provider will notify the Access Seeker if unable to obtain the third party's agreement to such terms.
- (e) If the Equipment of a third party needs to be moved, powered down or turned off in order for the Access Seeker to install or maintain its Equipment, the Access Seeker will be responsible for liaising with that third party and the Access Provider will provide the Access Seeker with the details of the third party. The Access Seeker must reimburse or pay all costs paid or payable by the Access Provider in relation to the movement, power down or turn off of the third party's Equipment in these circumstances.

17. INSURANCE

- (a) The Access Provider may in writing require the Access Seeker to maintain higher insurance coverage than that required under Clause 16.15 of the Supply Terms where the Access Provider reasonably believes that such higher insurance coverage is necessary given the level and nature of the Access Seeker's access to the Access Provider's Facilities. Where the Access Provider requires the Access Seeker to maintain higher insurance coverage under this paragraph, the Access Seeker must comply with any such requirements within thirty (30) Working Days of being so notified by the Access Provider.
- (b) On request by the Access Provider, the Access Seeker must immediately produce evidence that it has complied and is continuing to comply with its obligations under paragraph 18(a).

18. SUSPENSION AND TERMINATION

18.1 Suspension

The parties agree that the rights of suspension and termination under Clauses 12 and 13 (respectively) of the Supply Terms in respect of a Service under this Service Description shall apply.

18.2 Completion of suspension

The Access Provider must provide the Access Seeker with access to the relevant Facility as soon as practicable after there no longer exists a reason for suspension and must do so at a reasonable cost to the Access Seeker.

19. TERMINATION BY THE ACCESS PROVIDER

- (a) If the Access Provider:
- (i) intends to decommission the Facility and terminate the provision of access to that Facility; and
 - (ii) the Access Seeker wishes to continue to use the Facility, then the Access Provider must:
 - 1 release the Access Seeker from the Facility Sub-Lease and upon vacation of the Facility by the Access Provider, any obligations under this Service Description in respect of that Facility;
 - 2 where there is more than one Access Seeker sharing the Facility, permit the Access Seeker that was the first Licensed Operator to share the Facility (and if shared initially by more than one Access Seeker, by agreement between the Access Seekers) to take an assignment of or novate the Facility Lease from the Access Provider;
 - 3 indemnify the Access Seeker against any claims by the Lessor or any other person in respect of the Access Provider's use of the Facility; and
 - 4 make reasonable endeavours to incorporate this paragraph 19 into any negotiations with the Lessor regarding the execution or the renegotiation of the Facility Lease.
- (b) The Access Seeker, where it takes an assignment or novation of the Facility Lease, indemnifies the Access Provider against any claims, damages, expenses or liabilities in respect of the Facility arising after the date of the assignment or novation.

20. TERMINATION BY ACCESS SEEKER

If the Access Seeker decides to cease using a Shared Facility and the Access Provider wishes to continue using the Facility, the Access Seeker indemnifies the Access Provider against any claims by the Lessor or any other person in respect of the Access Seeker's use of the Facility, or the termination of the Facility Lease or Facility Sub-Lease.

21. CONSEQUENCES OF EXPIRY OR TERMINATION

- (a) Where a Facility Lease or Facility Sub-Lease has expired or terminated early including as a result of termination of the SP-Access Service, the Access Seeker must:
- (i) immediately remove the Access Seeker's Equipment from the relevant Facility, except where the Facility is a Tower in which case the Access Seeker must contract with the Access Provider to remove the Access Seeker's Equipment;
 - (ii) reinstate the Facility to the same standard, style and condition as existed prior to the installation of the Access Seeker's Equipment; and
 - (iii) do such other acts, matters and things as the parties may agree, and the Access Provider must allow the Access Seeker to enter onto the land on which the Facility is located in order to do so.

- (b) If the Access Seeker fails to comply with paragraph 21(a) within twenty (20) Working Days of such termination, the Access Provider may enter the Facility on reasonable notice for the purposes of carrying out any necessary disconnection works.
- (c) All reasonable costs of the disconnection described in paragraph 21(b) must be paid by:
 - (i) in the case of expiry of the relevant Facility Lease or Facility Sub-Lease, the Access Seeker;
 - (ii) in the case of disconnection due to termination of the SP-Access Service, the party other than the party who terminates the SP-Access Service; and
 - (iii) in the case of disconnection due to a Force Majeure Event under Clause 15 of the Supply Terms, the party affected by the Force Majeure Event.

22. LIABILITY AND INDEMNITY

- (a) This paragraph 22 applies in relation to access to Facilities under this Service Description and applies notwithstanding any inconsistency with Clause 16 of the Supply Terms.
- (b) The Access Provider shall not be liable to the Access Seeker (whether in contract, in tort, under statute or in any other way and whether due to negligence, willful or deliberate breach or any other cause) under, or for matters arising in relation to, this Service Description, a Facility Lease or Facility Sub-Lease for or in respect of:
 - (i) any consequential, special or indirect liability, loss, damage, cost, charge or expense;
 - (ii) any act or omission or matter relating to any third party, other than a properly authorised contractor (Approved Contractor) of the Access Provider acting within the scope of its authority involved in the operation or maintenance of a Shared Facility; or (iii) any delay in the initial provision or failure to provide access or for anything not under the direct control of the Access Provider.
- (c) The Access Seeker shall indemnify the Access Provider against any claim or cause of action (whether in contract, in tort, under statute or in any other way and whether due to negligence, willful or deliberate breach or any other cause) of a third party against the Access Provider for or in respect of all direct, consequential, indirect or special liability, loss, damage, cost, charge or expense incurred or suffered as a result of or in relation to the Access Seeker's access to Facilities under this Service Description, a Facility Lease or Facility Sub-Lease.
- (d) Subject to paragraphs (b) and (c), each party (**Indemnifying Party**) unconditionally and irrevocably indemnifies the other (**Innocent Party**) against all claims, actions, damages, losses, liabilities, costs, charges, expenses, outgoings or payment which the Innocent Party pays, suffers or incurs, or is liable for in connection with:
 - (i) any breach of this Service Description, a Facility Lease or a Facility Sub-Lease by the Indemnifying Party; or
 - (ii) damage to or loss of any Equipment, Facility or other property of the Innocent Party or a third party or injury to a person caused by an act or omission (negligent or otherwise) of the Indemnifying Party.

EARLY TERMINATION BY THE ACCESS SEEKER

- (a) Where the Minimum Service Period has not expired, the Access Seeker shall be entitled to terminate the SP Access Service on at least one (1) month's written notice to the Access Provider and shall be liable to pay liquidated damages as calculated by the following formula: $LD = MRC \times (N-M)$ where:
- LD = liquidated damages to be paid.
 - MRC = Monthly Recurring Charge for the SP Access Service.
 - M = number of months between the Actual RFS Date and the removal order date rounded-up to the next full month.
 - N = the number of months as per the applicable Minimum Service Period (i.e., twenty-four (24) or sixty (60) calendar months).
- (b) The Access Seeker shall not be liable to pay liquidated damages where the Access Seeker terminates the SP Access Service as a result of and/or arising out of a material breach of the Reference Offer by the Access Provider.
- (c) The Access Seeker expressly acknowledges that liquidated damages as calculated above form a reasonable pre-estimate of the loss which the Access Provider would suffer as a result of early termination by the Access Seeker. Such liquidated damages shall be the Access Provider's sole and exclusive damages or monetary remedy for such early termination.
- (d) Following the expiry of any Minimum Service Period the SP Access Service shall be automatically renewed for successive Renewed Minimum Service Periods unless and until terminated by the Access Seeker. During the Renewed Minimum Service Period, the Access Seeker may terminate the SP Access Service subject to providing the Access Provider with a written termination notice of at least one (1) month prior to the expiry of the Renewed Minimum Service Period. In the event that the Renewed Minimum Service Period expires, and the Access Seeker does not provide any written termination notice as above, the SP Access Service shall renew for a further Minimum Service Period.
- (e) The Access Provider may upon providing three (3) months' written notice to the Access Seeker and subject to the approval of the Regulator, vary the SP Access Service or withdraw the SP Access Service relating to the terms and Annexes in this Service Description, by issuing a revised Service Description.
- (f) Unless the Access Provider and Access Seeker agree otherwise at the time, any withdrawal or variation of the SP Access Service, or any amendment to the Charges payable for the SP Access Service in accordance with this Service Description and Schedule 3 – (Pricing) of the Reference Offer, shall also apply to existing SP Access Services provided under the Supply Terms, which shall continue in force in accordance with its terms and conditions until renewed or terminated in accordance with this Service Description or the Supply Terms.

**SCHEDULE 6.7 –
SERVICE DESCRIPTION**

SERVICE NODE FACILITIES MANAGEMENT SERVICE

1. THE SERVICE

The SNFM Service is an access service more particularly defined below which can be requested as part of any other relevant Reference Offer service.

Available To: Holders of an appropriate Individual Telecommunications or Class License granted by the Authority.

Traffic: N/A

2. DEFINITIONS

Capitalised terms not defined in this Service Description are defined in Schedule 8 – (Dictionary) of the Reference Offer. Terms defined in this Service Description are specific to it.

Access Provider Service Node (APSN) means an Access Provider exchange building specified in the list issued by the Access Provider.

Co-mingling means co-location as rack space where the Access Seeker Equipment is installed in an APSN in an area which may also house the Access Provider's Equipment or other Licensed Operator Equipment unpartitioned from the Access Seeker Equipment and from each other.

Contact Person means the Access Provider's personnel who can be contacted any time by staff and contractors of the Access Seeker who need to enter the SNFM Rack Space. The Access Provider guarantees that in case the Contact Person cannot be reached, another official from the Access Provider can be reached 24 hours a day, seven days a week.

Implementation Date means the date set out in a Service Request for a SNFM Service which shall be determined in accordance with the timescales set out in clause 11.11 of the Supply Terms.

Network Boundary means the Access Provider distribution point at customer premises contemplated by the Access Provider's fixed services license.

Access Seeker Equipment means all Equipment compliant with the ANFP or other equivalent specification, provided by the Access Seeker necessary to support the relevant Reference Offer service.

Point of Presence (POP) means an aggregation or network connection point in the Access Seeker's Network located at premises owned or shown to be leased by the Access Seeker or at an Access Provider collocation facility, but for the avoidance of doubt cannot be at an End User Premises, cable station, earth station, manhole, power room, lead-in pipe, duct, outdoor cabinet, MDF, riser room or anywhere not on the main island of Bahrain unless connected by a permanent physical connection above sea level and accessible by the Access Provider.

SNFM Service means the Service Node Facilities Management Service.

3. SERVICE TERMS

3.1 The SNFM Service in each APSN comprises:

- (a) SNFM Rack Space being Co-mingling,
- (b) Riser room access.
- (c) Raised Flooring.
- (d) Power – DC power only from an electrical distribution board and handed over at the relevant rack with a lug connector or depending upon the Access Seeker's Equipment, direct cable connection(s). DC and AC power supply/backup of 3 kW/h which can be increased in increments of 1kW/h up to a maximum of 7kW/h where applicable, subject to additional charges and which apply the same interruption and back up protection to this power supply as applies to other Access Seekers in the APSN.
- (e) Light to a reasonable standard.
- (f) Air conditioning – reasonable temperature and humidity control provided to Access Seekers Equipment complying with the Access Provider's specifications.
- (g) Access arrangements for Access Seeker staff and outside contractors.
- (h) Building maintenance and repair of the SNFM Rack Space to such standards as is adequate given the age and nature of the facility
- (i) Cleaning to a reasonable standard.
- (j) Earthing – standard point to multipoint.
- (k) Fire detection and suppression provided the Access Seeker insures its own Equipment against fire risk.
- (l) Maximum loading being 300kg per square meter for a wooden raised floor and 500kg per square meter for a steel raised floor.
- (m) Lead in trays for Tie Cables.

3.2 Provision of the SNFM shall be conditional on the Access Seeker:

- (a) entering into a SNFM License substantially in the form of Annex 1 in respect of each APSN.
- (b) providing a statement of conformity with the ANFP.
- (c) providing a copy of type approval certificates as described in paragraph 3.3(c) below.

- (d) providing of relevant and valid insurance documentation as specified under paragraph 9 of this Service Description and clause 17 of the Supply Terms.
 - (e) Completion of the relevant security requirements for Access Seeker staff and contractors as specified and referred to under paragraph 4.4 and Annex 3 of this Service Description.
- 3.3 The Access Seeker shall ensure that any Equipment connected to a fibre cable provided by the Access Provider:
- (a) meets the specifications and requirements defined by relevant international telecommunications and engineering standards;
 - (b) the ANFP; and
 - (c) is type approved equipment under article 38 of the Telecommunications Law and/or any type approval regulation issued by the Authority.
- 3.4 If the Access Provider terminates this Service in whole, then each SNFM License will terminate after expiry of the relevant notice period.
- 3.5 If a regulatory obligation to support or supply any specific SNFM Service no longer applies, the Access Provider may cease to supply the SNFM Service to an Access Seeker on 12 months prior written notice. Following the giving of a notice under this clause, the Access Seeker will not request any new SNFM Services from the Access Provider unless commercially agreed otherwise between the Access Provider and the Access Seeker. The Access Seeker will also inform any relevant End User that the SNFM Service will terminate at the end of the 12-month period.
- 3.6 The Access Provider may continue to provide, and the Access Seeker may continue to request this service from the Access Provider on commercial terms agreed mutually between the Access Provider and the Access Seeker.
- 3.7 Where the Access Provider has reasonable objective grounds to consider that the Access Seeker is in breach of an obligation under this Service, the Access Provider may, subject to Authority's approval: suspend implementation by the Access Seeker of the SNFM Service; and/or take any other step contemplated by the Supply Terms to protect the Access Provider's Network or other interests.
- 3.8 The Access Provider will make available to Access Seekers through the General Information request, the list of the APSNs available from time-to-time.

4. SNFM RACK SPACE

- 4.1 In relation to Co-mingling, the parties shall enter into a SNFM License in the form set out in Annex 1 of this Service Description.
- 4.2 Unless the Access Seeker specifically requests otherwise or there is no space available, the SNFM Rack Space shall be co-mingled inside the secure space of the facility and the Access Seeker acknowledges that other Access Provider customers and the Access Provider will have co-mingled access to the SNFM and Access Seeker Equipment.

- 4.3 Subject to paragraph 4.4 below, the Access Provider shall provide the Access Seeker with access to the SNFM Rack Space to allow the Access Seeker's People to access the SNFM Rack Space in order to enable the Access Seeker to perform their obligations under this Service.
- 4.4 The Access Seeker's People shall observe all of the Access Provider's instructions and procedures relating to this Service, including the Access Provider's security and site regulations. Nothing in any guidance, instruction or policy can be taken to mean that the Access Provider assumes any risk or responsibility in relation to the Access Seeker's service, Equipment or People. An indicative summary of the current security procedures and policies is set out in Annex 3 of this Service Description. Upon completion and acceptance of the Service Request form for this SNFM Service, the Access Seeker shall request and the Access Provider shall provide a copy of the Access Provider's summary security procedures which shall be amended from time to time in the Access Provider's absolute discretion. Enquiries about the details of any policy or procedure should be directed to the Access Seeker's account manager at the Access Provider.
- 4.5 The Access Provider will provide a safe working environment for any Access Seeker People at the SNFM Rack Space. The Access Seeker shall indemnify the Access Provider against all claims, charges, costs or expenses in any way relating to injury to or death of any Access Seeker People at or in the environs of the SNFM Rack Space that is not caused by the Access Provider, and against all loss of or damage to the Access Seeker Equipment or any other the Access Provider customer's Equipment at the SNFM Rack Space in any way connected with the Access Seeker's use of the SNFM Rack Space that is not caused by the Access Provider.
- 4.6 The Access Seeker understands and agrees that third parties such as the emergency services and law enforcement agencies may have a legal right of entry to SNFM Rack Space and the surrounding area at any time.
- 4.7 Access Seeker may enter the SNFM Rack Space solely for the purposes of installing, inspecting, maintaining, adjusting, repairing, altering, replacing or removing Access Seeker Equipment within the SNFM Rack Space in accordance with the SNFM License. The Access Seeker is not permitted to enter any other part of the APSN.
- 4.8 All Access Seeker access shall be escorted access, which comprises the provision of Access Provider staff to escort the Access Seeker's People to and from the SNFM Rack Space. Where the Access Provider's policies require supervision at the SNFM Rack Space, this will be at the Access Seeker's cost.

5. GENERAL SERVICE TERMS

- 5.1 The Access Seeker acknowledges:
- (a) The SNFM Service comprises the SNFM Rack Space and additional support services set out in this service description;
 - (b) This SNFM Services does not allow personnel of the Access Seeker physical access to any relevant Facility unless expressly stated in this service description.

5.2 Ordering

- (a) The Access Seeker shall submit a correctly completed Service Request to the Access Provider to request supply of the SNFM Service in accordance with this service description and the Supply Agreement. The Service Request shall be submitted in the form specified by the Access Provider from time to time.
- (b) To be valid, the Service Request shall be accompanied by a matching Reference Offer product for the relevant APSN to enable the Access Provider to implement the relevant SNFM Rack Space.
- (c) Subject to the Access Provider accepting the Service Request, and the Access Seeker fulfilling all of its obligations under the Supply Terms, the Access Provider will provide and the Access Seeker will acquire the SNFM Service as specified in the Service Request accepted by the Access Provider.
- (d) The provision of the SNFM Service is available as set out below, subject to availability of space, capacity and related equipment.

5.3 Variation

The Access Provider may at any time on reasonable notice, which shall be in all cases not less than 3 months, to the Access Seeker change the technical specification of the Service provided that any such change does not materially affect the substance of the performance of the Service.

6. CHARGES

- 6.1 The Access Seeker shall pay to the Access Provider the relevant Charges determined in accordance with Schedule 3 – (Pricing) of the Reference Offer.
- 6.2 The Billing Period in respect of the Service shall be 30 days. The Billing Period shall commence on the date of the first billing date of the Access Provider billing cycle after installation and may include billing on a pro rata time basis for the period between the date the Access Seeker was informed of the space being ready for it to install its equipment until the next billing cycle to ensure compatibility with the Access Provider billing cycle.

7. FORECASTING

- 7.1 At the beginning of each calendar month, the Access Seeker shall supply a reasonable non-binding forecast of the expected requests for the SNFM Service in each month of the twelve-month period following the date of the forecast, in the form required by the Access Provider from time to time. The Access Seeker shall use all reasonable endeavours to forecast accurately given the Access Provider is placing reliance on those forecasts to determine the number of requests expected for each month.
- 7.2 The Access Seeker acknowledges that the Access Provider is not liable for not delivering any additional Service Requests for the SNFM Service which has not been forecasted in accordance with paragraph 7.1 above.

8. INSURANCE

- 8.1 Until such time as the parties agree otherwise and after obtaining approval of the Authority for such amendment, the Access Provider and the Access Seeker shall each procure and maintain for the duration of this service third party liability insurance policies with the other being named as a named beneficiary to cover personal injury and property damage claims up to BD300,000 for each APSN. The terms of such policies shall include provisions whereby, in the event of any claim or proceedings under the policy being brought or made against the other party, the insurers shall indemnify the other party against any costs, charges and expenses thereof. At all times the parties shall hold appropriate workman's insurance (General Organisation for Social Insurance (“**GOSI**”)).
- 8.2 The Access Provider or the Access Seeker shall provide evidence of the insurance cover referred to in paragraph 9.1 on or before the date this service commences and thereafter at any time during the period of this service as the requesting party shall reasonably require. If the requested party is unable to demonstrate to the requesting party's reasonable satisfaction that it has insurance to the required level, with a reputable insurer, the requesting party shall be entitled to effect insurance against all claims, proceedings, losses, liabilities, costs, damages and expenses caused by the other party's negligence, other default or deliberate act arising out of or in connection with this service and to recover the reasonable cost of such insurance from the other party.

9. Disputes

- 9.1 Where there is any allegation of a failure to comply with the warranties of this Service Description then the parties will apply the dispute resolution process outlined in Clause 22 of Schedule 9 – (Supply Terms) of the Reference Offer.

ANNEX 1 – SNFM License

1. The Access Provider will grant to the Access Seeker, for the period set out in the agreed Service Request,, a License to use a portion of space in the Access Provider Floor/Ground APSN specified in the General Information list identified in a Service Request for SNFM Service access in writing which is signed by the Access Provider in accordance with the terms of this license, the SNFM Service Description and the Supply Terms.
2. The license does not commence unless and until:
 - (a) A Service Request for Floor/Ground access is accepted and signed by the Access Provider;
 - (b) all Make Ready Work has been completed to the Access Provider's and Access Seeker's satisfaction;
 - (c) all charges for the stages of the process occurring up to and including the completion of Make Ready Work have been paid; and
 - (d) the terms of this license have been signed by the Access Seeker.
3. The license is a personal and non-transferable right. The license does not confer any rights on the Access Seeker to lease, sub-lease or any right of ownership or possession in respect of any specific Floor/Ground. The Access Seeker may not sub-license any right granted by this license.
4. Unless specified in the SNFM Service Description, the Access Seeker does not have any general right to access to Floor/Ground and this license allows the Access Seeker to access the Floor/Ground route only in strict compliance with the Access Provider's access policies and procedures which apply from time to time relating to security, protection and safety, physical access procedures, marking of equipment. Such access shall be supervised by the Access Provider at all times.
5. It is a condition of the license that the Access Seeker shall:
 - (a) comply with the policies and directions of the Access Provider, including in relation to access, movement or relocation of a Floor/Ground route and relocation of the cable from, in, or between, sub-Floor/Grounds
 - (b) behave in a manner consistent with the action of a prudent Floor/Ground owner;
 - (c) so far as access is given, keep all cabling Equipment and all accessed Floor/Ground areas free of debris and in a safe and tidy condition;
 - (d) ensure no toxic or flammable materials are left anywhere near the Floor/Ground or Equipment;
 - (e) promptly notify, for correction or removal, any fault or defect in Equipment used in or near the Floor/Ground; and
 - (f) immediately notify the Access Provider of any damage to Floor/Ground or Equipment observed or occurring during or as a result of access by the Access Seeker.

6. The Access Provider may require from the Access Seeker to remove and replace any Equipment which does not comply with any municipal, Ministry or Authority requirements or restrictions.
7. For the sake of clarification, maintenance of the Access Seeker Space shall be carried out by the Access Provider and the corresponding charge is included in the License fee (as set out in Schedule 3 – (Pricing) of the Reference Offer).
8. If the Access Provider by reasonable notice to the Access Seeker requires the movement of the Access Seeker's Floor space for The Access Provider's own convenience then the Access Provider will cover the cost of moving the Co-mingling and the Access Seeker may attend to observe at its own expense.
9. If part or all of the Co-mingling needs to be moved for reasons outside the control of the Access Provider and by order of a competent court, municipality, authority, Ministry or Authority, the Access Seeker must share a proportion of charges or costs related to the move of its Equipment, upon justified and reasonable methodology approved by the Authority.
10. the Access Provider may immediately suspend provision of the service until further notice if the Access Seeker causes, or the Access Provider can justify that the Access Seeker will cause, physical or technical harm to any telecommunications network (whether of the Access Provider or another operator).
11. The Access Provider may terminate the license granted to the Access Seeker on 30 days written notice to the Access Seeker if:
 - (a) The Access Seeker is in breach of the SNFM Service description which is left unremedied for a period of 21 days after written notification by the Access Provider to the Access Seeker;
 - (b) fibre is not lit along the full route of the Floor/Ground access for any consecutive period of 12 months during the term of the license;
 - (c) the Access Seeker ceases to be a Licensed Operator; or
 - (d) the Access Seeker installs Equipment in or near any Floor/Ground which does not meet the requirements specified in 3.3 (c) above.
12. The Access Provider may terminate the license granted to the Access Seeker on 6 months written notice to the Access Seeker if the Access Provider's right to use the Floor/Ground or right of way is revoked, terminates or expires.
13. Either party may terminate the license immediately if the other party is in breach of the license or of the Supply Terms as they relate to the Floor/Ground and the breach remains unremedied for a period of 10 Working Days.
14. The Access Seeker may in any case terminate the license by giving the Access Provider six months written notice.

15. If the license is terminated then the Access Seeker shall remove all Equipment from, in and around the Floor/Ground within 90 days of the notice of termination. If the Access Seeker fails to comply with this clause then the Access Provider is entitled to remove the Access Seeker's Equipment at the latter's costs.
16. The Access Seeker will be deemed to have abandoned the Access Seeker's Equipment if it does not access the Equipment for any period of 24 consecutive months. If the Access Seeker's Equipment is abandoned then the Access Provider may exercise the same rights as for the removal of Access Seeker Equipment as indicated in paragraph 15 above.

The terms of this license take precedence over any other terms which might apply to the Access Seeker's access to the Access Provider's Co-mingling.

SCHEDULE 1 – SNFM License

Licensed Floor/Shelter Area

APSN

**Leased/Owned outright by BAHRAIN NETWORK (BNET) B.S.C (C) Designated Floor
Area (sq. meter)**

*Note: the details listed above will be provided and attached to each SNFM License granted to the Access
Seeker*

ANNEX 2 – SNFM CHARGES

The Access Seeker shall pay to the Access Provider the relevant Charges as set out in Schedule 3 – (Pricing) of the Reference Offer.

ANNEX 3 – SUMMARY OF SECURITY REQUIREMENTS

1. General Access

- 1.1 All Access Seeker People requiring access to SNFM should have the Access Provider issued contractor ID Cards. ID holders should report to Security when requiring access.
- 1.2 As an exceptional alternative, Access Seeker People requiring access to SNFM can be registered by The Access Provider. Registered technicians requiring access to the relevant APSN or site area shall report to Security. Security will check their central population register (“CPR”) or national identity card or other means of photographic ID against the list of Access Seeker authorised People. If everything is correct, Security will issue an appropriate ID Card in exchange for the persons ID; details will be recorded by the security staff.
- 1.3 ID holders or registered technicians will be escorted to and from the SNFM.
- 1.4 Supervision of work whilst the person is inside the relevant APSN or site area is at the discretion of the Access Provider.

2. Emergency Event Access

- 2.1 No unregistered emergency access will be allowed unless access has been agreed by the BNET Security through liaison with the Access Seeker account manager following notification. The notification should provide relevant personal details, the Access Seeker whose equipment is to be worked on and the date/times(s) of the access required and the circumstances of the emergency.
- 2.2 The persons requiring access shall report to security. Security will check their CPR or other means of photographic ID against the personal details provided to the BNET Security.
- 2.3 If everything is verified, Security will issue an appropriate ID Card in exchange for the persons ID; details will be recorded by the security staff.
- 2.4 The person will be escorted to and from the SNFM.

3. Refusal of Access

- 3.1 The Access Provider reserves the right to refuse access to any non-registered visitor of the Access Seeker for the reasons below:-
 - (a) Visitors without photographic ID.
 - (b) Visitor who cannot provide a valid contact name and number.
 - (c) Visitors whose contact person cannot be contacted or reached.
 - (d) Visitors who have disregarded rules in the past.
 - (e) During times of emergency.

SCHEDULE 6.8 – SERVICE DESCRIPTION

NETWORK RIGHT OF USE SERVICE (NRU)

1 SERVICE DESCRIPTION AND TERMS OF USE

- 1.1 The Network Right of Use Service (the “**NRU**”) involves a service, as further described in this Schedule, provided by the Access Provider to the particular Access Seeker, which has transferred its Fibre Capacity to the Access Provider under a separate bilateral commercial asset transfer agreement between both parties to fulfil the single network objective of the Government’s National Telecommunications Plan Nos. 4 and 5, and Article 40 bis(a) of the Telecommunications Law of the Kingdom.
- 1.2 The NRU Service involves the grant of an indefeasible right of use of such Fibre Capacity to the extent to which:
- (a) control over and ownership and title to the specific Fibre Capacity has been transferred from the Access Seeker to the Access Provider; and
 - (b) such Fibre Capacity was used solely for the operation of the Access Seeker’s mobile backhaul, connections between core network nodes, or for connecting the Access Seeker’s network to cable landing stations or international gateways.
- 1.3 The NRU Service involves the exclusive and indefeasible right to use such Fibre Capacity by the respective Access Seeker for its connectivity needs consistent with the scope as described above in Clause 1.2 for a period of twenty (20) years following completion and effectuation of their transfer to the Access Provider (the “**NRU Term**”) unless terminated earlier in accordance with the provisions of this Service Description.
- 1.4 The NRU Service includes:
- (a) Provision by the Access Provider within the Access Provider’s licensed fixed telecommunications infrastructure of the necessary duct hosting for the Transferred Fibre Assets. The provision of the duct hosting for the Transferred Fibre Assets is dependent on and ancillary to the NRU Service and does not involve granting of a separate duct licence to the Access Seeker;
 - (b) Exclusive and indefeasible right to use the Transferred Fibre Assets by the respective Access Seeker for the entire duration of the NRU Term on the price and non-price terms stipulated in this Schedule 6.8 (Service Description) and Schedule 3 (Pricing) subject to payment of the applicable NRU Service Charges by the Due Date; and
 - (c) Provision by the Access Provider of repair and maintenance services related to the Transferred Fibre Assets upon request by the Access Seeker and, where applicable, charged as per the list of Charges under Schedule 3 (Pricing).
- 1.5 The right to use the Transferred Fibre Assets granted under the NRU is granted on ‘as is’ basis, reflecting the technical and other conditions as well as their location, distance, reach and extension within the territory of the Kingdom of Bahrain as of the time of their transfer from the Access Seeker to the Access Provider. However, if the location of the Transferred Fibre Assets is required to be changed at the request of a competent authority, then provided (i) the Access Seeker submits a

request in writing; and (ii) the Access Seeker confirms that the number of mobile network end points does not increase; and (iii) the relocation is limited to a distance of 500 meters from the original location then the Access Provider shall facilitate such a relocation. All the costs for carrying out the relocation shall be borne exclusively by the Access Seeker. However, the monthly recurring charge for the NRU shall not be increased as a result of the relocation.

- 1.6 When providing the NRU Service, the Access Provider shall not be responsible for any technical characteristics, quality, fitness for a particular purpose, or the remaining useful life of the Transferred Fibre Assets following their transfer to the Access Provider. Furthermore, the Access Provider shall not be responsible for any deterioration of their characteristics, performance or function during the NRU Term as a result of normal wear and tear or damage or loss caused by a third party outside of the Access Provider's control.
- 1.7 Where the Access Seeker requires replacement of the Transferred Fibre Assets, during the NRU Term, and unless such requirement is contrary to the terms stipulated in this Schedule 6.8 (Service Description), the Access Provider shall be obliged to perform the necessary removal, installation, and other similar maintenance services, upon the Access Seeker's request and at the Charges stipulated in Schedule 3 (Pricing).
- 1.8 Except as provided for in Clause 1.5, the Access Provider shall not be obliged, and the Access Seeker shall not be entitled to request, any extension or other change to the existing location, distance, reach or footprint of the Transferred Fibre Assets beyond that reflecting their status as of date of their transfer to the Access Provider.
- 1.9 The NRU Service involves a personal and non-transferable right. The Access Seeker is not allowed to resell the NRU Service to another Licensed Operator. The NRU Service does not confer on the Access Seeker a lease, sub-lease or any right of ownership or possession in respect of Access Provider's duct or any other similar civil infrastructure assets of the Access Provider. The Access Seeker may not share or sub-license any right granted under the NRU Service.
- 1.10 The Access Seeker does not have any general rights of access to duct(s) or any other similar civil infrastructure assets of the Access Provider including the Transferred Fibre Assets. Any repair, maintenance, replacement, removal or any other activity that is reasonably necessary in relation to the Transferred Fibre Assets shall be exclusively conducted by the Access Provider.
- 1.11 The Access Provider shall be entitled to suspend or terminate the NRU Service following the process envisaged in Schedule 9 (Supply Terms) of the Agreement.
- 1.12 Either Party may terminate the NRU Service on thirty (30) days' notice if:
 - (a) the Access Seeker ceases to be a Licensed Operator, or
 - (b) the Access Seeker no longer wishes to avail itself of the NRU Service, whether in its entirety for all affected Transferred Fibre Assets or for a specific subset thereof.
- 1.13 To the extent that there is any conflict or inconsistency between this Service Description and any other parts of the Reference Offer, the provisions of this Service Description shall take precedence.
- 1.14 To the extent that Fibre Capacity is used to provide connections to enterprise customers pursuant to agreements that are in place as at 19 June 2024 which are not provided using current RO products ('Existing Enterprise Agreements'), that shall be considered as part of the NRU throughout the remainder of its term. Provided however, that the term of agreement may not be amended or

renewed. In all cases this consideration shall be valid for a maximum period of five (5) years such that as at 18 June 2029, all Existing Enterprise Agreements must be based on other products within BNET's RO.

2 DEFINITIONS

Capitalised terms not defined in this Service Description are defined in Schedule 8 - (Dictionary) of the Reference Offer. Terms defined in this Service Description are specific to it and, in case of any inconsistency, shall prevail over Schedule 8 (Dictionary).

Asset Migration Plan means the plan for migration of assets from Batelco to BNET which was submitted to the Authority on 30 June 2022.

Fibre Capacity means the Fibre Cables which formed part of the licensed fixed telecommunications network of the relevant Access Seeker transferred to the Access Provider under the Asset Transfer Agreement ('ATA') or in the case of Batelco, the fibre capacity already transferred to the Access Provider and subject to the Asset Migration Plan.

Fibre Cable(s) means the physical fibre optic cable(s) including all individual fibre strands contained within the protection and external sheath of such cable and any directly related accessories that must not be separated from such cable(s).

NRU or '**NRU Service**' means the Network Right of Use Service as described in this Service Description to be provided for the NRU Term and on the price and non-price terms stipulated in this Schedule 6.8 (Service Description) and Schedule 3 (Pricing).

Transferred Fibre Assets means the Fibre Capacity to which control of and ownership and title to have been transferred from the relevant Access Seeker to the Access Provider under the respective ATA.

3 MAINTENANCE AND SUPPORT

- 3.1 Access Provider shall be obliged to provide repair and maintenance services in respect of the NRU Service in accordance with the terms of the Agreement.
- 3.2 Access Seeker may report a Fault to the Access Provider's nominated contact point which shall be available twenty-four (24) hours per day every day.
- 3.3 Access Provider shall record the Fault using a unique reference which it shall pass to the Access Seeker at the same time as acknowledging the Fault and both parties shall agree the time of the report. The Access Provider shall acknowledge the fault within fifteen (15) minutes and shall commence repair of the Fault within:
 - (a) Five (5) hours during Working Hours; or
 - (b) Twelve (12) hours outside of Working Hours from the time of the Access Seeker reported the Fault and shall restore the NRU Service in accordance with the Service Levels. The Access

Provider shall advise the Access Seeker's nominated contact point once the Fault is clear and both parties shall record the time of this clearance.

- 3.4 All repair, maintenance or any other activities related to the Transferred Assets shall be carried out by the Access Provider at Charges stipulated in Schedule 3 (Pricing).
- 3.5 If and where required, the Access Seeker shall reimburse the Access Provider for all costs associated with the removal and replacement of any Transferred Fibre Asset which did not comply with the requirements or restrictions imposed by any competent authority in the Kingdom. Provided that the Access Provider shall, upon request of the Access Seeker, provide evidence to the Access Seeker of any notice or request for removal or replacement by the competent authority.
- 3.6 If the Access Provider, by reasonable notice to the Access Seeker, requires relocation or other movement of the Transferred Fibre Assets at the Access Provider's own volition, then the Access Provider shall cover the cost of relocating or moving the Transferred Fibre Assets and the Access Seeker may request to be present and attend to observe at its own expense. In exercising its rights under this Clause 3.6, in order to minimize disruption to the Access Seeker's services, the Access Provider shall use reasonable commercial endeavours to carry out joint planning and co-ordination with the Access Seeker.
- 3.7 Where relocation or other movement of the Transferred Fibre Assets is required by a competent authority or any relevant third party, the Access Provider shall exercise all commercially reasonable endeavours to seek reimbursement of all costs by such competent authority or any relevant third party. If full reimbursement of all costs by such competent authority or any relevant third party is not possible, such costs shall be borne by the Access Provider.
- 3.8 Where replacement of any Fibre Capacity (or part thereof) is required, and unless otherwise agreed between the parties, the Access Provider shall procure (at the Access Seeker's cost) the replacement material to be supplied to the Access Provider by an Approved Contractor. The Fibre Capacity must comply with the Access Provider's specifications notified to the Access Seeker and any requirements imposed by competent authority in the Kingdom. Provided that where the Fibre Capacity (or parts thereof), has been replaced by the Access Provider upon request from the Access Seeker and at the Access Seeker's cost in accordance with this Clause 3.8, then the costs for any subsequent request for replacement, (as long as that subsequent request is not frivolous) during the NRU Term, shall be borne by the Access Provider.

4 CHARGES

- 4.1 The Access Seeker shall pay to the Access Provider the relevant Charges determined in accordance with Schedule 3 - (Pricing) of the Agreement.
- 4.2 All Charges and sums due from one party to the other under this Agreement are exclusive of VAT. Any VAT shall be charged in accordance with the relevant regulation in force at the time of making the taxable supply and shall be paid by the paying party following receipt from the billing party of a valid VAT invoice.
- 4.3 All Charges for the NRU Service shall be considered fixed and shall not be subject to review or change during the entire duration of the NRU Term. This is an essential element of the NRU Service

considering the recovery of the acquisition costs for the Transferred Fibre Assets incurred by the Access Provider.

- 4.4 The Access Seeker indemnifies and holds the Access Provider harmless from municipality charges or other taxes or charges that may be levied from time to time in connection with the provision or use of ducts or the Transferred Fibre Assets and if such charges are levied only on the Access Provider, the Access Seeker must promptly reimburse the Access Provider a portion of charges allocated to the Access Seeker by the Access Provider, in proportion to the share of usage of the duct infrastructure and/ or the Transferred Fibre Assets used and the allocation of the levies and charges.

SCHEDULE 7

SERVICE LEVELS

This Schedule 7 sets out the Service Levels and Service Level Penalties (Service Credits) for the Services in the Reference Offer.

CONDITION PRECEDENT TO MEETING SERVICE LEVELS

- A. BNET's ability to meet certain Service Level may be dependent on certain third parties (including but not limited to Government authorities, ministries and municipalities) for the purpose of obtaining, inter alia, authorisations, wayleaves, or any other permission as long as the Access Provider made all reasonable efforts to obtain them, including making the relevant applications in a timely manner, notifying the Access Seeker of such requirement and keeping the Access Seeker updated on the progress.

- B. Where the Access Seeker has requested the suspension of a Service Order for a relevant Reference Offer Service, the Service Level related to that Reference Offer Service shall be suspended until the Access Seeker notified BNET in writing that it wishes to proceed with the Service Order.

WHOLESALE BITSTREAM SERVICE (WBS)

Service Level Type	Business Process	Service Level Terms	SLA	Responsibility	Service Level Penalties
Service Order Acknowledgement	Maximum Time for Service Order Acknowledgment	During Working Hours	15 minutes	Access Provider	N/A
		Outside Working Hours	15 minutes		
Service Order Confirmation	Maximum Time for Service Order Confirmation	During Working Hours	2 Working Days	Access Provider	10 SC for each Working Day after the Maximum Time for Notification of Expected RFT and RFS Dates until such time as the MNO receives the Notification.
Service Order Completion RFS Date (New Provide) - WBS Essential	Order-To-Payment -Maximum Delivery Time	<p>Subject to availability of GPON fibre and other conditions stipulated in Schedule 6.1</p> <p>In case of a WBS Transfer Request as defined in Decision No. 2 of 2021 or any applicable Decision and/or Regulation relating to WBS Transfer as issued by the Authority, the timelines set out in such Decision and/or Regulation will apply.</p>	10 Working Days (from Service Order Confirmation)	Access Provider	<p>10 SC for each additional Working Day thereafter until the Access Seeker receives the RFS Certificate.</p> <p>(There is no Maximum Penalty Cap per Connection).</p>
Order Completion RFS Date (New Provide) - WBS Advanced	Order-To-Payment Maximum Delivery Time	<p>Subject to availability of GPON fibre and other conditions stipulated in Schedule 6.1</p> <p>In case of a WBS Transfer Request as defined in Decision No. 2 of 2021 or any applicable Decision and/or Regulation relating to WBS Transfer as issued by the Authority, the timelines set out in such Decision and/or Regulation will apply.</p>	5 Working Days (from Service Order Confirmation)	Access Provider	50 SC for failure to meet the Maximum RFS Date and 25 SC for each additional working day thereafter until the Access Seeker receives the RFS Certificate. (There is no Maximum Penalty Cap per Connection).

Service Order Completion RFS Date (New Provide) - Premium Service Delivery	Order-To-Payment Maximum Delivery Time Premium Service Delivery	Premium Service Delivery in 24hours if no civil works is required.	24 hours (subject to service confirmation that premises is home connect and the order being placed during working hours)	Access Provider	No applicable service credit as this is an optional service. If Access Provider is unable to deliver within 24hours, Access Provider will not charge Access Seeker the premium delivery charge
Order Completion RFS Date (New Provide) – both WBS Essential and Advanced	Order-To-Payment Maximum Delivery Time	Maximum delivery time for Service Orders impacted by civil infrastructure issues	60 Calendar Days (subject to obtaining the necessary approvals, including wayleaves, permission, etc)	Access Provider	10 SC for each additional working day Working Day thereafter until the Access Seeker receives the RFS Certificate. (There is no Maximum Penalty Cap per Connection).
Order Completion (Internal Relocation, Upgrade & Downgrade)	Request to Change (Internal Relocation, Upgrade & Downgrade)	Maximum Delivery Time	Internal Relocation subject to End User premises readiness: 10 Working days An Internal Relocation follows the same process as a new provide whereby the Access Seeker must select an available appointment slot for the request. Upgrade & Downgrade: 5 Working Days	Access Provider	10 SC for each additional working day Working Day thereafter until the Access Seeker receives the RFS Certificate. (There is no Maximum Penalty Cap per Connection)
Order Completion (Service Termination)	Termination To Confirmation	Maximum Delivery Time	5 Working Days	Access Provider	No SC. The Access Provider will not bill the Access Seeker if a Service is terminated beyond the 5 Working Days

Order Completion External Relocation)	Request to Change	Maximum Delivery Time	10 Working Days	Access Provider	10 SC for each additional working day Working Day thereafter until the Access Seeker receives the RFS Certificate. The Maximum Penalty per Connection is Capped at 1 Month Rental equivalent to a total of 100 SC).
Service Request Acknowledgement	Request to Answer: for Service Request for Fibre Cost Assessment - Maximum Time for Service Request Acknowledgment	During Working Hours	15 minutes	Access Provider	N/A
		Outside Working Hours	15 minutes	Access Provider	N/A
Service Request Answered	Request to Answer: for Service Request for Fibre Cost Assessment - Maximum Time to answer a request	Service Request for fibre cost assessment answered	10 Working Days	Access Provider	N/A
Fault Acknowledgement Time	Problem-To-Solution - Maximum Fault Acknowledgement Time	During Working Hours and Outside Working Hours	15 minutes	Access Provider	N/A
Response Time	Problem-To-Solution - Maximum Response Time	During Working Hours	5 Working Hours	Access Provider	N/A
		Outside Working Hours	12 hours		
Restoration Time (WBS Essential)	Problem-To-Solution - Maximum Restoration Time	During Working Hours and Outside Working Hours	48 hours	Access Provider	20 SC for failure to meet the Maximum Restoration Time and 10 SC for each hour exceeding the Maximum Restoration Time. (There is no Maximum Penalty Cap per Connection).

Restoration Time (WBS Advanced)	Problem-To-Solution - Maximum Restoration Time	During Working Hours and Outside Working Hours	<p>During Working Hours: 12 hours</p> <p>Outside Working Hours: 24 hours</p> <p>For either scenario, this excludes any fibre cable cut and/or outages requiring civil works</p>	Access Provider	20 SC for failure to meet the Maximum Restoration Time and 10 SC for each hour exceeding the Maximum Restoration Time. (There is no Maximum Penalty Cap per Connection).
---------------------------------	--	--	---	-----------------	--

WHOLESALE DATA CONNECTION (WDC)

Service Level Type	Business Process	Service Level Terms	SLA	Responsibility	Service Level Penalties
Service Order Acknowledgement	Order-To-Payment - Maximum Time for Service Order Acknowledgment	During Working Hours and Outside Working Hours	15 minutes	Access Provider	N/A
Service Order Confirmation	Order-To-Payment - Maximum Time for Service Order Confirmation	During Working Hours and Outside Working Hours	2 Working Days	Access Provider	N/A
Notification of Expected RFS Date	Order-To-Payment - Request to Change Maximum Time for Notification of Expected RFS Date	Upgrade/Downgrade order and Cancellation Request	5 Working Days	Access Provider	25 SC for each Working Day after the Maximum Time for Notification of Expected RFT and RFS Dates until such time as the MNO receives the Notification.
		For a Cancellation Request, the Access Provider shall only provide the Maximum RFS Date, which shall be the expected date of cancellation, taking into account the required notification period for cancellation			
		New Connection order and Internal & External Relocation	5 Working Days	Access Provider	
RFS Date	Maximum Delivery Time – Order-To-Payment & Request to Change	Request to Change Upgrade/Downgrade order, Internal Relocation and Cancellation Request	10 Working Days	Access Provider	50 SC for failure to meet the Maximum RFS Date and 25 SC for each additional Working Day thereafter until the Access Seeker receives the RFS Certificate. (There is no Maximum Penalty Cap per Connection).
		Order-To-Payment & Request to Change New Connection& External Relocation orders:		Access Provider	
		<ul style="list-style-type: none"> When a fiber cable is available 	10 Working Days	Access Provider	
		<ul style="list-style-type: none"> When a fiber cable is not available, but there is sufficient duct space to pull in an additional access cable 	20 Working Days	Access Provider	

		<ul style="list-style-type: none"> When new duct must first be installed before deploying a new fibre access cable 	60 Calendar Days or Exceptional Delivery	Access Provider	
		Cancellation Requests do not have a Maximum Delivery Time: the Maximum Date (i.e., expected cancellation date) must be defined to take account of the one month notification period required for cancellation.		Access Provider	
		In case of Relocation Order, the Access Provider shall coordinate the deactivation and activation of the Connection on the same day to ensure minimum service disruption		Access Provider	
		For Bulk Projects (i.e. From 15 circuits per order), the Access Provider shall agree with the Access Seeker on a Time table to deliver the project	Subject to mutual agreement between the Parties	Access Provider	
Service Request Acknowledgement	Request to Answer: for Service Request for Service Access Resource feasibility assessment Maximum Time for Service Request Acknowledgment	Within Working Hours	15 minutes	Access Provider	N/A
		Outside Working Hours	15 minutes	Access Provider	N/A
Service Request Answered	Request to Answer: for Service Request for Service Access Resource feasibility Assessment	Service Requests for Service Access Resource feasibility assessment answered	10 Working Days	Access Provider	N/A

	Maximum Time to answer a request				
Appointment Management	Appointment Booking	Original appointments to be booked by Access Seeker	2 Working Days	Access Seeker	N/A
Fault Acknowledgement Time	Problem-To-Solution Maximum Fault Acknowledgement Time	During Working Hours and Outside Working Hours	15 minutes	Access Provider	N/A
Response Time	Problem-To-Solution Maximum Response Time	During Working Hours	1 Working Hours	Access Provider	N/A
		Outside Working Hours	2 hours		
Restoration Time	Problem-To-Solution Maximum Restoration Time	Depending on the type of support	4 hours for Standard Support 2 hours for Premium Support For either Support type, this excludes fibre cable cut and civil works.	Access Provider	For Standard Support: 20 SC for failure to meet the Maximum Restoration Time and 10 SC for each hour exceeding the Maximum Restoration Time. (There is no Maximum Penalty Cap per Connection). For Premium Support: 50 SC for failure to meet the Maximum Restoration Time and 25 SC for each hour exceeding the Maximum Restoration Time. (There is no Maximum Penalty Cap per Connection).

MOBILE DATA SERVICE MANAGED (MDS-M)

Service Level Type	Business Process	Service Level Terms	SLA	Responsibility	Service Level Penalties
Service Order Acknowledgement	Order-To-Payment Maximum Time for Service Order Acknowledgment	During Working Hours	15 minutes	Access Provider	N/A
		Outside Working Hours	15 minutes	Access Provider	
Service Order Confirmation	Order-To-Payment Maximum Time for Service Order Confirmation	During Working Hours and Outside Working Hours	2 Working Days	Access Provider	N/A
Notification of Expected RFS Dates	Order-To-Payment & Request to Change Maximum Time for Notification of Expected RFS Date	Upgrade/Downgrade Order and Cancellation Request	5 Working Days	Access Provider	25 SC for each Working Day after the Maximum Time for Notification of Expected RFT and RFS Dates until such time as the MNO receives the Notification.
		For a Cancellation Request the Access Provider shall only provide the Maximum RFS Date, which shall be the expected date of cancellation, taking into account the required notification period for cancellation			
		New Connection order and Internal & External Relocation	5 Working Days	Access Provider	
RFS Date	Maximum Delivery Time – Order-To-Payment & Request to Change	Request to Change Upgrade/Downgrade Order, Internal Relocation and Cancellation Request	10 Working Days	Access Provider	50 SC for failure to meet the Maximum RFS Date and 25 SC for each additional Working Day thereafter until the Access Seeker receives the RFS Certificate.
		Order-To-Payment & Request to Change New Connection & External relocation orders		Access Provider	
		<ul style="list-style-type: none"> When a Service Access Resource is available for a new connection 	10 Working Days	Access Provider	(There is no Maximum Penalty Cap per Connection).
		<ul style="list-style-type: none"> When a Service Access Resource is not available for a new connection 	20 Working Days	Access Provider	

		but there is sufficient duct space to pull in an additional access cable			
		<ul style="list-style-type: none"> When new ducts must first be installed before deploying a new access cable 	60 Calendar Days or Exceptional Delivery	Access Provider	
		Cancellation Requests do not have a Maximum Delivery Time: the Maximum RFS Date (i.e., expected cancellation date) must be defined to take account of the one month notification period required for cancellation.		Access Provider	
		In case of Relocation order, the Access Provider shall coordinate the deactivation and activation of the Connection on the same day to ensure minimum service disruption		Access Provider	
		For Bulk Projects (i.e. From 15 circuits per order), the Access Provider shall agree with the Access Seeker on a Time table to deliver the project	Terms on Agreement	Access Provider	
Service Request Acknowledgement	Request to Answer: for Service Request for Service Access Resource feasibility Assessment - Maximum Time for Service Request Acknowledgment	Within working hours	15 minutes	Access Provider	N/A
		Outside Working Hours	15 minutes	Access Provider	N/A
Service Request Answered	Request to Answer: for Service Request	Service Requests for Service Access Resource feasibility	10 Working Days	Access Provider	N/A

	for Service Access Resource feasibility Assessment - Maximum Time to answer a request	assessment answered			
Fault Acknowledgement Time	Problem-To-Solution Maximum Fault Acknowledgement Time		15 minutes	Access Provider	
Response Time	Problem-To-Solution Maximum Response Time	During Working Hours	1 Working Hours	Access Provider	N/A
		Outside Working Hours	2 hours		
Restoration Time	Problem-To-Solution Maximum Restoration Time		4 hours This excludes fibre cable cut and civil works.	Access Provider	20 SC for failure to meet the Maximum Restoration Time and 10 SC for each hour exceeding the Maximum Restoration Time.
Service Trouble Ticket Creation	Problem-To-Solution	service trouble tickets supplied with correct information	Supplying correct information At the time or raising trouble tickets is access seeker responsibility	Access Seeker	(There is no Maximum Penalty Cap per Connection).

MOBILE DATA SERVICE UNMANAGED (MDS-U)

Service Level Type	Business Process	Service Level Terms	SLA	Responsibility	Service Level Penalties
Service Order Confirmation	Order to Payment Maximum Time for Service Order Confirmation	Access Provider may return the Service Order to Access Seeker if incomplete information	5 Working Days	Access Provider	N/A
Notification of Expected RFS Dates	Order-To-Payment & Request to Change Maximum Time for Notification of Expected RFS Date	Solution design will be provided based on MDS-U requirement with expected RFS	30 Working Days	Access Provider	N/A
		Confirm solution design acceptance	15 Working Days	Access Seeker	
RFS Date	Maximum Delivery Time –Order-To-Payment & Request to Change	RFS date is based on the proposed solution. Implementation of the requested MDS-U as provided in Solution Design stage after the confirmation by Access Seeker	Based on the proposed plan	Access Seeker and Access Provider	N/A
		In case of external relocation, the Access Provider shall coordinate the deactivation and activation of the Connection on the same day to ensure minimum service disruption		Access Provider	
Fault Acknowledgement Time	Problem-To-Solution Maximum Fault Acknowledgement Time	During Working Hours and Outside Working Hours	15 minutes	Access Provider	N/A
Response Time	Problem-To-Solution Maximum Response Time	During Working Hours	5 Working Hours	Access Provider	N/A
		Outside Working Hours	12 hours		
Restoration Time	Problem-To-Solution Maximum Restoration Time	During Working Hours and Outside Working Hours	48 hours	Access Provider	20 SC for failure to meet the Maximum Restoration Time and 10 SC for each hour exceeding the

					Maximum Restoration Time. (There is no Maximum Penalty Cap per Connection).
--	--	--	--	--	---

The same SLAs shall continue to apply to any FFS connections provided before the effective date of introduction of the MDS-U.

CORE CONNECT AND LANDING STATION SERVICE (CCLS)

Service Level Type	Business Process	Service Level Terms	SLA	Responsibility	Service Level Penalties
Service Order Acknowledgement	Order-To-Payment - Maximum Time for Service Order Acknowledgment	During Working Hours and Outside Working Hours	15 minutes	Access Provider	N/A
Service Order Confirmation	Order-To-Payment Maximum Time for Service Order Confirmation	During Working Hours and Outside Working Hours	2 Working Days	Access Provider	N/A
Notification of Expected RFS Dates	Order-To-Payment & Request to Change Maximum Time for Notification of Expected RFS Date	Cancellation Request	5 Working Days	Access Provider	N/A
		For a Cancellation Request the Access Provider shall only provide the Maximum RFS Date, which shall be the expected date of cancellation, taking into account the required Notification period for cancellation			
		New Connection Order and External Relocation Order	5 Working Days	Access Provider	
RFS Date	Maximum Delivery Time – Order-To-Payment & Request to Change	Request to Change Cancellation Request	10 Working Days	Access Provider	50 SC for failure to meet the Maximum RFS Date and 25 SC for each additional Working Day thereafter until the Access Seeker receives the RFS Certificate. (There is no Maximum Penalty Cap per Connection).
		Order-To-Payment & Request to Change New Connection & External Relocation orders		Access Provider	
		<ul style="list-style-type: none"> When an access cable is available 	10 Working Days	Access Provider	
		<ul style="list-style-type: none"> When an access cable is not available but there is sufficient duct space to pull in an additional access cable 	20 Working Days	Access Provider	

		<ul style="list-style-type: none"> When new ducts must first be installed before deploying a new access cable 	60 Calendar Days or Exceptional Delivery	Access Provider	
		Cancellation Requests do not have a Maximum Delivery Time: the Maximum RFS Date (i.e., expected cancellation date) must be defined to take account of the one month notification period required for cancellation.		Access Provider	
		In case of External Relocation Order, the Access Provider shall coordinate the deactivation and activation of the Connection on the same day to ensure minimum service disruption		Access Provider	
		For Bulk Projects (i.e. From 15 circuits per order), the Access Provider shall agree with the Access Seeker on a Time table to deliver the project	Terms on Agreement	Access Provider	
Service Request Acknowledgement	Request to Answer: for Service Request for Service Access Resource feasibility Assessment Maximum Time for Service Request Acknowledgment	Within working hours	15 minutes	Access Provider	N/A
		Outside Working Hours	15 minutes		
Service Request Answered	Request to Answer: for Service Request for feasibility	Service Requests for Service Access Resource feasibility	10 Working Days	Access Provider	N/A

	Assessment Maximum Time to answer a request	assessment answered			
Fault Acknowledgement Time	Problem-To-Solution Maximum Fault Acknowledgement Time	During Working Hours and Outside Working Hours	15 minutes	Access Provider	N/A
Response Time	Problem-To-Solution Maximum Response Time	During Working Hours	2 Working Hours	Access Provider	N/A
		Outside Working Hours	4 Working hours		
Restoration Time	Problem-To-Solution Maximum Restoration Time	During Working Hours and Outside Working Hours	4 hours This excludes fibre cable cut and civil works.	Access Provider	15 SC for failure to meet the Maximum Restoration Time and 10 SC for each hour exceeding the Maximum Restoration Time. (There is no Maximum Penalty Cap per Connection)
Service Trouble Ticket Creation	Problem-To-Solution	service trouble tickets supplied with correct information	Supplying correct information At the time or raising trouble tickets is access seeker responsibility	Access Seeker	
Service Trouble Ticket Creation	Problem-To-Solution	service trouble tickets attended due to access seeker issues/access seeker service trouble tickets where fault not found		Access Seeker	
Service Trouble Ticket Creation	Problem-To-Solution	service trouble tickets attended due to access seeker issues/access seeker service trouble tickets where fault not found		Access Seeker	

STRATEGIC PARTNER ACCESS TO PASSIVE INFRASTRUCTURE (SP-ACCESS)

Please refer to Schedule 6.6 (Service Description)

KEY PERFORMANCE INDICATORS (KPI)

Service	KPI	Target
MDS Managed (MDS-M)	Maximum Time for Notification of Expected RFT and RFS Date	95% within 5 Working Days
	Maximum Delivery Time (when fibre is available)	95% within 10 Working Days
	Maximum Restoration Time	95% within 4 hours
MDS Unmanaged (MDS-U)	Maximum Delivery Time (Access Delivery Date)	90% within 5 Working Days after physical installation
Wholesale Data Connection (WDC)	Maximum Time for Notification of Expected RFT and RFS Date	95% within 5 Working Days
	Maximum Delivery Time (when fibre is available)	95% within 10 Working Days
	Maximum Restoration Time	95% within 4 hours (Standard support) 95% within 2 hours (Premium support)
Wholesale Bitstream Service (WBS)	Maximum Time for Notification of Expected RFT and RFS Date	99% within 1 Working Day
	Maximum Delivery Time	95% within 10 Working Days
	Maximum Restoration Time	95% within 48 hours
Core Connect and Landing Station Service (CCLS)	Maximum Time for Notification of Expected RFT and RFS Date	95% Within 5 Working Days
	Maximum Delivery Time (when fibre is available)	95% Within 10 Working Days
	Maximum Restoration Time	95% Within 48 Hours
Access Provider Wholesale Portal	Portal availability (365 days per year, at all times)	98% availability
Quality of Service Parameters	As defined in Service Descriptions	95% of each QoS parameters per circuit met in a calendar month (e.g., Jitter, RTD, Latency – in line with the parameters of the relevant Service Descriptions)
Early Life Faults	Faults reported within 10 Working Days of the Service Request (order) being completed	<5%
Faults on Service Provisions	Faults within 48 hours of the Service Request (order) being completed (Dead on Arrival)	<3%
Repeat and persistent Faults	Faults within 5 Calendar Days of Fault Restoration on the same Connection or Installation (as appropriate)	<5%

SCHEDULE 8 – DICTIONARY AND RULES OF INTERPRETATION AND CONSTRUCTION PART 1 –

DICTIONARY

Unless defined otherwise or unless the context otherwise requires, capitalised words used in this Agreement shall have the meaning given to them in this Schedule:

Acceptable Long Term Credit Rating means a credit rating (which shall not be more than six (6) months old) from (i) either Moody's Investor Services, of "BA" or higher, or (ii) from Standard & Poors, of "BB" or higher.

Acceptance Criteria means the set of technical parameters including the Quality of Service Parameters, and test procedures, which the Service has to meet before a Service Order can be considered as completed.

Access Provider means BAHRAIN NETWORK (BNET) B.S.C (CLOSED), which is licensed by the Authority to provide the Services to Licensed Operators.

Access Provider's Equipment means equipment owned, controlled, managed, operated, provided by, installed or utilised by, the Access Provider, which is instrumental for providing by the Access Provider, the relevant Service to the Access Seeker.

Access Seeker means, in relation to a Service, the Licensed Operator that has requested the Access Provider to supply that Service.

Access Seeker Customer means an End User connected to the Access Seeker's Network to whom the Access Seeker supplies end to end services utilizing the Service provided by the Access Provider as input to such services.

Actual RFS Date means the date:

- (a) on which the End User or the Access Seeker, as applicable, signs the RFS Certificate, where the Service or other chargeable work or activity, is subject to acceptance or testing, or
- (b) the RFS Date, where the Service is not subject to acceptance or testing.

For avoidance of doubt, refusal or a failure to sign the RFS Certificate without cause shall not delay the Actual RFS Date.

Affiliate means, as used with respect to any person, any other person directly or indirectly Controlling, Controlled by, or under common Control with, that person, and "**Affiliated**" shall be construed accordingly.

Agreement Effective Date means the date on which the Parties executed in writing Schedule 9

(Supply Terms), which incorporates, by reference, all other Schedules, parts and provisions of the Reference Offer, as may be amended from time to time, subject to the Access Seeker fulfilling all applicable conditions for entering into the Agreement as stipulated by the relevant provisions of the Reference Offer.

Approved Contractor means a Person who meets the relevant standards, codes of practice and/or certifications of the Access Provider for the purposes of relevant work or activity required to supply a Service, and is recognised and/or notified by the Access Provider to the Access Seeker as such.

Authorized Person has the meaning set out in Schedule 9 (Supply Terms).

Authority means the Telecommunications Regulatory Authority of the Kingdom of Bahrain.

Autonomous System or **AS** means the collection of routers and associated Network elements under a single administration using a common BGP for routing packets.

Billing Process means the billing and payment process as described in Schedule 4 (Billing) of the Reference Offer.

Billing Dispute has the meaning set out in clause 9 (Billing Disputes) of Schedule 4 (Billing).

Billing Dispute Escalation Procedure has the meaning set out in clause 10 (Billing Disputes) of Schedule 4 (Billing).

Billing Dispute Notice means a notice in writing setting out the information required under clause 10 (Billing Disputes) of Schedule 4 (Billing) of the Reference Offer.

Billing Representative means the individual or department nominated by either Party, to receive, process or issue the Invoices and communicate with the other Party in all matters related to billing.

BNET License means the Fixed Telecommunications Infrastructure Network License granted to BNET on 2 June 2019 by the Regulator, pursuant to the requirements of Article 40(bis)(a) of the Law.

Calendar Day or “**day**” means a period of 24 consecutive hours and ending at 24:00 midnight including weekends and public holidays.

Calendar Year means each year commencing on 1 January and ending on 31 December.

Cancellation Request means a request to cancel an existing transaction including any Service Order, as applicable.

Change of Control means a material change in the equity structure of a company giving rise to a change in the ability of a stakeholder to appoint the board of the company.

Charges mean any applicable charges, fees, prices, amount or calculation of monies applicable to any Service as set out in Schedule 6 (Service Descriptions) and in Schedule 3 (Pricing) of the Reference Offer, as the case may be.

Connection means a subset of a Service, which may refer to an individual physical and/ or logical connection or circuit to the End User or a facility of the Access Seeker or another Licensed Operator; as applicable; in relation to the specific Service as further described in Schedule 6 (Service Descriptions).

Confidential Information means all information or business secrets in whatever form reasonably considered to be commercially confidential (regardless of whether it has been formally designated as such) and shall include without limitation information pertaining to network coverage and/or capabilities, product development, product pricing, marketing strategy and intelligence, product launch dates, projected sales volumes, cost, payment terms, product specific forecasting, trade secrets, ideas, concepts, know-how, knowledge, and information whether in writing or otherwise, relating to a party's People, services, Network, commercial affairs, business, customers, subscribers or End Users as exchanged between the Parties before, on or after the Agreement Effective Date but excludes information:

- (a) which is in or becomes part of the public domain other than through breach of this Agreement or an obligation of confidence owed to the Disclosing Party;
- (b) which a Party can prove by contemporaneous written documentation was already known to such Party at the time of disclosure by the Disclosing Party (other than if such knowledge arose from disclosure of confidential information in breach of an obligation of confidentiality);
- (c) which the recipient acquires from a third party entitled to disclose it; or
- (d) which was independently developed by a Party without breach of any obligation of confidentiality owed to the other Party.

The Confidential Information of the Licensed Operators under the Agreement involves in particular but without limitation:

- (a) any forecast provided to the Access Provider pursuant to Schedule 5 (Forecasting);
- (b) any Service Order submitted to and its processing by the Access Provider;
- (c) unless otherwise provided, any New Service Order submitted to the Access Provider;
- (d) any information provided to the Access Provider in the course of its review of the the Access Seeker creditworthiness or any Security requested from or provided by the Access Seeker;

- (e) any information related to any Dispute including a Billing Dispute;
- (f) any information provided to the Access Provider under the Agreement, which, in the case of written or electronic information, is clearly designated by the Licensed Operator as commercially confidential and which, in the case of information disclosed orally, is identified at the time of disclosure as such or is by its nature as commercially confidential.

Confidentiality Agreement means the terms and conditions of the mutual confidentiality obligations between an Access Seeker and the Access Provider prior to the Agreement Effective Date as provided for in Schedule 9 (Supply Terms).

Confidential Customer Information has the meaning as defined in Clause 19 (Confidentiality) of Schedule 9 (Supply Terms).

Consequential Loss means:

- (a) direct loss of business, revenues, opportunity or profits; and
- (b) indirect, incidental, consequential, punitive or special damages, including economic loss such as loss of profits or expectations, business revenue, goodwill, wasted expenditure or anticipated savings, cost of replacement services, whether such costs or damages are based in contract, tort (including negligence), statute or otherwise, even if the other Party is warned or has been warned of the possibility of that loss or damage.

Control means, as applied to any person, the possession, directly or indirectly, of the power to influence the direction of the management of that person, whether through ownership, voting or other means, and “Controlling” and “Controlled” shall be construed accordingly.

Credit Note means a credit note issued in writing by the Billing Party to the Billed Party under this Agreement as a result of a Billing Dispute as per clause 9.12 (d)(ii) of Schedule 4 (Billing) or in response to a Service Credit Claim raised by the Billed Party under this Agreement and acknowledged and agreed to by the Billing Party in writing, or in other instances envisaged by this Agreement, which stipulates a concrete amount in Bahraini Dinars owed by the Billing Party to the Billed Party.

Customer Premises Equipment or “CPE” means equipment owned, controlled, operated or used by the Access Seeker, which is necessary to make use of the Service, but is not supplied by the Access Provider. The specific characteristics of various types of Customer Premises Equipment in relation to specific Services are described in Schedule 6 (Service Descriptions). A specific instance of such Customer Service Equipment is End User Equipment necessary for End User’s use of a Service supplied to the Access Seeker as further described in Schedule 6 (Service Descriptions).

Decision of the Authority means any decision, ruling, determination, instruction, approval, order or directive or such other regulatory requirement of the Authority, which is binding and enforceable on the Access Provider and/ or the Access Seeker, as applicable.

Disclosing Party has the meaning set out in Schedule 9 (Supply Terms).

Dispute has the meaning set out in Schedule 9 (Supply Terms).

Dispute Officer means a senior executive of a Party nominated to negotiate and resolve disputes with the other Party as further referred to in Schedule 9 (Supply Terms).

Dispute Resolution Procedures means the procedures set out in in Schedule 9 (Supply Terms).

Distribution Point generally refers to the Network Facility on the Access Provider's Network located in the vicinity of the End User's premises but before any NTP, which hosts Access Provider's Network Equipment and from which the Access Provider provides network connections to offer Services to the Access Seeker. The respective descriptions of particular Services in Schedule 6 (Service Descriptions) and any diagrams therein provide illustrative examples of the Access Provider's Network topology including the location of the Distribution Point and/ or the NTP, as applicable, in relation to a particular Service.

Downgrade means a decrease in the speed, bandwidth, capacity or throughput of the relevant Service or Connection as further defined in the relevant Service Description and corresponding Operations Manual, and 'Downgrade Request' has a corresponding meaning.

Duct means an underground facility that is used, installed and ready to be used, or intended to be used, to hold lines or cables and owned, maintained or operated by the Access Provider.

Due Date means the date on which an Invoice is payable in accordance with Schedule 4 (Billing) of the Reference Offer, as indicated by the Access Provider on an Invoice and, where such date is not expressly mentioned, it shall be a date which is thirty (30) days from the date of receipt of the relevant Invoice.

Emergency Event means an event (which may be a Force Majeure Event) which poses an urgent threat, or has caused actual damage, to any persons or property at the Facility or to any of the Equipment at the Facility, or the operating capability of the Access Provider's Equipment, the Access Seeker's Equipment or third party Equipment in a material way. Such events include, but are not limited to, fire, electrical malfunction, or structural damage. It also includes an unscheduled Outage which has or is likely to have a significant impact on a Party's Network.

Emergency Maintenance means work required in response to an Emergency Event in order to protect or restore any Equipment, the Facility, or the operating capability of Equipment.

End User means the Licensed Operator's customer, to whom the Access Seeker provides, or intends to provide, a service using the particular Service (as described in Schedule 6 (Service Descriptions)) provided by the Access Provider as an input, whether a legal or natural person. Schedule 6 (Service description) may provide further categorisation of End User(s) in relation to their eligibility for certain Service, where applicable.

End User Consent means the express written consent obtained, or required to be obtained, by an

Access Seeker from the Access Seeker Customer to subscribe to or receive a service from the

Access Seeker by means of the relevant Service supplied by the Access Provider to the Access Seeker under this Reference Offer or any changes, migrations or transfers thereof. Where the context of the relevant Service (as provided for in Schedule 6 (Service Descriptions)) so requires, such consent may involve a confirmation to the Access Seeker that the End User has obtained necessary consents, approvals, no objections, rights of way and/or rights of access, to the extent that such are within the control of the End User to obtain and are reasonably required to enable the Access Provider to provide the relevant Service.

End User Management means all aspects of communication or interaction with the End User by the

Access Seeker in relation to each End User contracting with the Access Seeker for using the Access Seeker's services relying on the Service and first line support by the Access Seeker in relation to maintenance issues related to the End User.

End User Premises means the End User's permanent physical location in Bahrain where the Access Provider installs its ONT and/or Access Seeker the CPE. In this definition, 'permanent' means the End User's habitual place of residence or business, as applicable.

Equipment means equipment that is owned or used by a person and used or designed to be used for the supply of a telecommunications service by means of radiocommunications or any other means and includes:

- (a) antennae, microwave dishes or satellite dishes of less than 2.5 meters in diameter;
- (b) associated transmission equipment, power plant (including standby power), and air conditioning plant;
- (c) associated feeders, waveguides and waveguide pressuring equipment;
- (d) cabling and cabling works;
- (e) prefabricated modules, risers or other structures housing any of the above;
- (f) cable gantries;

- (g) lines, joints/splices and such other ancillary equipment as necessary to support the use of a line which may be housed in pits or manholes where suitable space is available or as agreed between the parties;
- (h) towers, masts, poles, antennae mountings and other similar structures which bear or are capable of bearing items noted in paragraph (a) – (g);
- (i) Underground Plant; and (j) such other ancillary equipment as may be agreed by the Parties from time to time.

Equipment Shelter means a building or other structure constructed or installed by a Party to house Equipment.

Equivalence Compliance and Technical Committee or the “**ECTC**” means the committee established by the Regulator pursuant to section 4.13 of the BNET’s Licence that will enable, among other things, Licensed Operators to discuss their needs and requirements, including technical requirements, with the Access Provider at regular intervals as described in the ECTC terms of reference published by the Regulator on 7 November 2019, as amended from time to time.

Exceptional Delivery Date means the alternative Delivery Date, notified by the Access Provider to the Access Seeker when the Expected RFS Date cannot be met due to exceptional circumstances as specified in the relevant Service Description in Schedule 6.

Expected RFS Date means the date on which the Access Provider expects the Service to be ready for Service as indicated in the notice of Expected RFT and RFS Dates. The Expected RFS Date shall be set no later than the Maximum Delivery Date.

Facility means a:

- (a) Duct;
- (b) fibre cable (whether partially or fully in service or not);
- (c) copper cable (whether partially or fully in service or not);
- (d) main distribution frame;
- (e) equipment room;
- (f) local exchange;
- (g) Duct chamber;
- (h) Underground Plant;
- (i) power room;
- (j) street cabinet;
- (k) riser room;
- (l) fibre patch panel as the context requires, which unless agreed otherwise by the Access Provider and Access Seeker, is or shall be owned by the Access Provider at the time a Service Order is made.

Fault means a fault arising in segments of a Network (classified as either a Carrier System Fault or a Network Fault).

Fault Acknowledgement means acknowledgement of a Fault in accordance with the provisions in Schedule 7 (Service Levels).

Field Study means the study to be undertaken by the Access Provider, which includes but is not limited to:

- a) details of the Make Ready Work required (including who will be responsible for undertaking each part) and the time required to perform the Make Ready Work;
- b) the estimated Charges for Make Ready Work; and
- c) the time required to access the relevant Service, after being ordered.

Forecasting Procedures means the procedures set out in Schedule 5 (Forecasting) of the Reference Offer.

Force Majeure Event means any act, event, omission, cause or circumstance that:

- a. is not within the reasonable control of an affected Party;
- b. the affected Party is not reasonably able to prevent or overcome by the exercise of reasonable care, such as by having in place or implementing a business continuity or disaster recovery plan; and
- c. causes the affected Party to fail to perform or otherwise materially affects the performance of any of its obligations under this Agreement and in particular, with respect to the Access

Provider, the provision of the Services but does not include:

- 1 any event or circumstance that arises as a result of any lack of funds or any other inability to pay money;
- 2 any industrial dispute relating to a Party or any other failure in a Party's supply chain; or
- 3 any event or circumstance that arises as a result of any willful or negligent act or omission of the affected Party or its failure to take reasonable care or precaution.

A Force Majeure may involve, without limitation, governmental or states' acts or regulations, embargoes, warfare, riots, earthquakes, hurricanes, lightning, fire, flood, or other inclement weather or natural disaster, act of terrorism, explosions, massive blackouts or an industrial dispute, or breakout of large scale serious contagious diseases or pandemics.

Indemnifying Party means the Party giving an indemnity under the Agreement as described in Schedule 9 (Supply Terms).

Insolvent means, in relation to a Party, where a Party is (i) unable to pay its debts on the maturity dates or fails to pay such debts within 30 days of their maturity or from date of the creditors' notice to pay; or (ii) the value of the debtor's financial obligations exceeds the value of its assets.

Insolvency Proceedings means any voluntary or involuntary petition under any bankruptcy, insolvency or similar law affecting creditors generally, or any liquidation, transformation or rehabilitation proceeding, or in relation to a Party, having receiver or similar person or entity appointed for any of its property.

Intellectual Property Rights means all rights conferred under statute, common law and equity in and in respect of intellectual property rights, including trade-marks, trade names, logos and get up, inventions, patents, designs, copyright, circuit layouts, Confidential Information, know-how and trade secrets, whether registered or not, and all rights and interests in them whether vested or contingent or licenses to use any of them.

Invoice means a bill or invoice issued by the Billing Party to the Billed Party for Services or other chargeable activities under this Agreement, as further described in Schedule 4 (Billing).

Kingdom means Kingdom of Bahrain.

Law means the Legislative Decree No. 48 of 2002 with respect to Telecommunications in the Kingdom of Bahrain, as amended from time to time.

License means an individual license issued pursuant to the Law and “Licensed” shall be construed accordingly.

Licensed Operator means a Party who has been issued with a telecommunications License pursuant to the Law to provide telecommunications services.

Main Body Terms means Main Body (Schedule 1) of the Reference Offer.

Make Ready Work means the work that is reasonably necessary to make a Facility ready for Equipment installation by the Access Seeker and/or the Access Provider which may include (but is not limited to):

- (a) structural analysis;
- (b) strengthening, modifying or augmenting a Tower necessarily and proportionally required to condition the Tower to bear the wind and weight loading directly added by the Access Seeker's Equipment;
- (c) constructing, installing or modifying head frames, cable risers, cable trays and other Tower fittings required to house the Equipment of the parties on the Tower;
- (d) where the Tower is a replacement Tower, removing the Tower if required;
- (e) constructing a New Facility or replacement Tower, including all design, approval and construction work and the doing of relevant things lawfully required by the Regulator;
- (f) rearranging Equipment;
- (g) the provision of temporary facilities to accommodate Equipment;
- (h) making alterations to ducts;

- (i) providing ducts, installing subducts and manhole breakouts, clearing roots or silt and repair work;
- (j) installing or extending cable trays or other works to house the Access Seeker's lines, cables and/or any Equipment; and (k) any other matters specified by the parties from time to time.

Material Breach means a breach of the Access Seeker's obligations under this Agreement, including without limitation a failure by the Access Seeker to pay any amount of an Invoice (other than subject to a Billing Dispute) by the Due Date, which in itself, or when combined with other breach of the Access Seeker's obligations under the Agreement, represents a serious violation of the terms of a contract, which if the Access Provider would have known before entering into the contract, would likely prevent or dissuade it from concluding such contract, or is reasonably considered as causing serious harm to the Access Provider.

Maximum Delivery Date means the last working day after which the Maximum Delivery Time lapses.

Maximum Delivery Time means the maximum time within which the Access Provider shall set the Expected RFS Date in the notice of Expected RFT and RFS Dates. The Maximum Delivery Time may differ according to the type of Service Order and/or the availability of access lines or access ducts. The Maximum Delivery Time starts at Accepted Service Order.

Maximum Fault Acknowledgment Time means the maximum Actual Fault Acknowledgment Time that the Access Provider should meet as required under Schedule 7 (Service Levels) of the Reference Offer.

Migration Request means, subject to further specifications in Schedule 6 (Service Description) a Service Order for changing the End User address of an existing Connection which may require disconnection and reconnection of the Connection end point. A "hot migration" happens when the Connection is not disrupted and a "cold migration" when the Connection can be disrupted.

Minimum Service Period has a meaning given to it in each applicable Service Description (Schedule 6), if and where applicable.

Mobile Network means:

- (a) a GSM Network; or
- (b) a mobile telephone network used and accessible by the public provider of switching and transmission facilities using digital technologies as defined in a globally accepted standard which the Licensed Operator is permitted to use by its License.

Monthly Recurring Charge (MRC) means the monthly Service Charge chargeable by the Access Provider and payable by Access Seeker.

Network means a public telecommunications network or system of a party, which is used or intended to be used for telecommunications services supplied under the party's License.

Network Fault means a Fault located within the Access Provider's Network or within the Licensed Operators Network. Network Faults include Faults within the signaling networks.

Network Termination Point (NTP) is a physical point located on End User's premises, at which an End User is provided with access to a public electronic communications Network and, where it concerns electronic communications Networks involving switching or routing, that physical point is identified by means of a specific network address, which may be linked to the telephone number or other identifier. NTP provided at a fixed location on served premises usually involves some form of Network termination and testing or diagnostics apparatus of the Access Provider.

New Connection Request means a Service Order for establishing a new Connection for the provision of Services to End User Premises.

New Service means (i) a completely new Service relating to access to the Access Provider's Network or (ii) any enhancement, alteration, modification or other change to an existing Service, its terms and conditions, technical parameters, features or functionalities or bandwidth including introducing any new pricing terms or service levels, or the underlying systems or processes that is not currently expressly provided for or able to be provided under the terms of the Reference Offer.

New Service Order means a request for a New Service submitted by a Party in accordance with the provisions of Annex 1 to the Main Body (Schedule 1) of the Reference Offer.

NOC means a no-objection certificate or any other consent, permit, approval or authorisation required to be issued by a competent authority or any relevant third party including without limitation landlords, property owners or developers, which is necessary in order for the Access Provider to conduct any works or other activities necessary for the supply of Service or its repair and maintenance.

Non-recurring Charge (NRC) means one-time charges for the installation, delivery, activation or other one-time activity or work in relation to a Service and may include situations where additional infrastructure is required to provide new or extended service at End User's Premises, or at another location where the Access Provider would otherwise not choose to extend its network.

Notification means a written communication sent by any means as described in Schedule 9 (Supply Terms).

Notification of Expected RFS Dates means the Service Level for the timely notification of the Expected RFS Date as provided for under Schedule 7 (Service Levels) of the Reference Offer.

Operations Manual means the annex of each Service Description describing the various processes relating to onboarding, provisioning, fulfilment and assurance.

Outages mean that period during which the Access Provider's Equipment is temporarily decommissioned or not operating.

People means directors, officers, employees, agents, contractors, advisors and representatives other than that Party's customers who act as end users of services provided by means of the Services.

Planned Maintenance means planned work to protect or restore any Equipment, the Facility, or the operating capability of Equipment, which is not in response to an Emergency Event.

Point of Presence (POP) means a permanent physical location where an aggregation link or connection of a relevant Service is terminated at premises owned or leased by the Access Seeker or at the Access Provider's colocation facility, but for the avoidance of doubt cannot be at an End User Premises, earth station, manhole, power room, lead-in pipe, duct, outdoor cabinet, MDF, riser room or anywhere not on the main island of Bahrain unless connected by a permanent physical connection above sea level and accessible to the Access Provider.

Public Internet Protocols means the following:

- (a) Hyper Text Transfer Protocol (HTTP);
- (b) File Transfer Protocol (FTP);
- (c) Simple Message Transfer Protocol (SMTP);
- (d) Secure HTTP; and
- (e) such other Internet protocols as the parties may agree from time to time.

Public Radio Communications Station shall have the meaning as defined in the Regulation on Permitting, Installation, Upgrading and Maintenance of Public Radio Communications Stations issued by the Regulator's Board of Directors Decision No. 10 of 2018 but excluding Temporary Public Radio Communications Stations as also defined therein.

Quality of Service (QoS) Parameters or **Quality of Service** means the set of technical parameters for a Service set out in the relevant Schedule 6 (Service Descriptions).

RFS Certificate means an acceptance form signed by either the End-User or the Access Seeker, as applicable, confirming that:

- (a) the Service has been provisioned and tested by the Access Provider;
- (b) the Service is properly registered in the Access Provider's systems;
- (c) the Service has been validated by the Access Seeker (or deemed to have been validated by the Access Seeker) or the End User, as applicable; and
- (d) the Service is Ready for Service and the Access Seeker will be invoiced accordingly.

Ready for Service Date or '**RFS Date**' means the date on which the Access Provider completes the delivery, installation or activation of the Service or any chargeable work or activity under the Agreement, as applicable, in accordance with Schedule 7 (Service Levels).

Reference Offer means the reference offer published by the Access Provider incorporating the Services (including any price and non-price terms) to be offered by the Access Provider to Licensed Operators, as may be amended from time to time, as approved by the Authority.

Regulatory Event means:

- (a) an amendment of or change in any applicable law;
- (b) the grant of an injunction against a Party in respect of a breach or alleged contravention of the applicable law; or
- (c) any change in the applicable telecommunication regulatory framework in the Kingdom of Bahrain pertaining to any regulatory instruments issued by the Authority or any Decision by the Authority;
- (d) the making of a determination or direction by, or an omission of, a competent authority.

Response Time means the Service Level for the timely start of troubleshooting of a Fault following the Fault Acknowledgement.

Restoration Time means the Service Level for the timely restoration of a Service affected by a Fault following the Fault Acknowledgement.

RO Effective Date means the date on which the Authority granted its approval of the Reference Offer (or any amendments or modifications thereto) or issued an order having the same effect following submission of the draft Reference Offer (or any amendments or modifications thereto) to the Authority for their review.

Security (or **Financial Security**) means any security reasonably required by the Access Provider in accordance with the Agreement. The form of security may include a bank guarantee, a letter of credit, security over a bank deposit or a parent company guarantee, provided that the form of security selected is acceptable to the Access Provider, such acceptance not to be unreasonably withheld or delayed.

Service means a service that the Access Provider is obliged to supply to the Licensed Operators under the BNET License issued pursuant to the requirements of Article 29 and Article 40(bis)(a) of the Law. As of the RO Effective Date, such Service(s) is/are described in the relevant Service Description in Schedule 6 (Service Descriptions) of the Reference Offer. A Service may also result from a New Service Order, which was implemented by the Access Provider using the process described in Annex 1 to the Main Body of the Reference Offer.

Service Credit (SC) means an amount payable by the Access Provider to the Access Seeker for a failure to meet a Service Level. In relation to a single Service Credit, it means that amount represented by 1% of the MRC.

Service Credit Claim means a claim by the Access Seeker in writing for application of a Service Level Penalty expressed in Service Credit(s) that is based on the Access Provider's non-compliance with a particular Service Level as described in Schedule 7 (Service Levels), and which is accompanied by reasonable supporting evidence of such non-compliance, as raised to the Access Provider within the timelines stipulated in this Agreement.

Service Description means the description, terms and procedures and other matters relevant to a particular Service and which are set out in Schedule 6 (Service Descriptions) of the Reference Offer.

Service Level or '**SLA**' means the set of parameters defining the minimum performance expected from the Access Provider in the Service Order processing, delivery and maintenance including fault repair, of the relevant Service, as further specified in a specific Service Level Term, as stipulated in Schedule 7 (Service Level).

Service Level Penalty/ies means the set of defined penalties expressed in Service Credits which are payable by the Access Provider for not having met the relevant Service Level.

Service Level Terms means the set of terms and conditions describing the application of a Service Level to a particular activity by the Access Provider, as set out in Schedule 7 (Service Levels) of the Reference Offer.

Service Qualification means the analysis carried out by the Access Provider via the Internet or manually to confirm whether the Service can be provided on the Access Provider Network by checking, where appropriate, the following:

- i. line loss;
- ii. infrastructure availability;
- iii. interference.

Service Order means a formal request for a Service made by an Access Seeker as outlined in Schedule 2 and defined in more detail in the relevant Operations Manual.

Service Order Acknowledgment means the Service Level for the timely acknowledgment of a Service Order sent by an Access Seeker as required under Schedule 7 (Service Levels) of the Reference Offer.

Service Order Confirmation means the Service Level for the timely acceptance or rejection of a Service Order sent by an Access Seeker as required under Schedule 7 (Service Levels) of the Reference Offer.

Service Order Form means the standard format (including digital format) used by an Access Seeker to request a Service as required under Schedule 2 (Notification and Acceptance of Service Order) or Schedule 7 (Service Levels) of the Reference Offer.

Service Order Acceptance means acceptance of a Service Order placed by the Access Seeker by the Access Provider as set out in Schedule 2 (Notification and Acceptance of Service Order) or Schedule 7 (Service Levels) of the Reference Offer.

Service Request means a request made by the Access Seeker but not a Service Order to: (i) check whether the address is currently served by BNET's infrastructure and/or (ii) confirm whether BNET can provision the infrastructure to the address on a time and materials basis (i.e., provide cost assessment).

Shared Facility means a Facility that is shared between Access Seeker(s) and/or the Access Provider.

Statement of Requirements means a formal description of a New Service, to be submitted by the Access Seeker following the initial and the detailed discussions between the Access Provider and the Access Seeker, addressing in detail the technical and functional characteristics and commercial terms as well as other terms relating to its supply as agreed by the Parties pursuant to the Annex 1 to the Main Body of the Reference Offer.

Supply Terms means the terms set out in Schedule 9 (Supply Terms) of the Reference Offer.

Suspension Event means:

- (a) the Access Seeker has failed to pay undisputed monies owing under the Agreement;
- (b) the Access Seeker breaches any other material obligation under the Supply Terms.

TCP/IP means transmission control Protocol/Internet Protocol in general use in accordance with good practice.

Term means the term of the Agreement, which starts on the Agreement Effective Date, and continues until terminated in accordance with the provisions of the Agreement.

Tower means the towers, poles, masts or similar structures and facilities used in the supply of a telecommunications service by means of radiocommunications or any other means and owned, maintained or operated by the Access Provider or the Access Seeker as appropriate.

TR69 means the TR69 protocol understood as CPE WAN Management Protocol, issued by the Broadband Forum in force from time to time, and/or its equivalent successor.

Underground Plant means:

(a) duct systems containing one or more ducts or subducts and includes associated building entry tunnels, manholes, exchange cable chambers and joining pits; and (b) tunnel systems.

Upgrade means upgrading the speed, bandwidth, capacity or throughput of an existing Service or Connection as further defined in the relevant Service Description and corresponding Operations Manual, and 'Upgrade Request' has a corresponding meaning.

Wireless Radio Site means a mast, tower, pole or roof top radio station or any other type of Public Radio Communications Station, excluding temporary cell sites (cell on wheels) owned, leased or licensed by Access Seekers that hold an Individual Mobile Telecommunications License.

Working Day means any day other than (i) Friday, (ii) Saturday or (iii) any other day to be officially determined as a non-working day or (iv) public holiday in the Kingdom of Bahrain.

Working Hours means between the hours of 08:00 to 17:00 AST on a Working Day.

PART 2 – RULES OF INTERPRETATION AND CONSTRUCTION

Interpretation Unless otherwise specified:

- (a) singular includes the plural and vice versa;
- (b) different grammatical forms of the same word have the corresponding meaning;
- (c) words of inclusion are not words of limitation;
- (d) the expression “person” includes a reference to a person, firm, corporation or other legal entity;
- (e) references to either party shall include its legitimate successors or assigns;
- (f) a reference to a part, Schedule, Clause, annexure or attachment is a reference to a part, schedule, clause, annexure or attachment forming part of the Reference Offer or the Agreement between the Access Provider and an Access Seeker, as the case may be; (g) headings are used for convenience only and do not affect interpretation.

SCHEDULE 9 - SUPPLY TERMS

1 COMMENCEMENT AND REVIEW

- 1.1 As set out in Clause 2 of the Main Body of the Reference Offer (Making an Agreement under the Reference Offer), and taking account of any existing contractual arrangement between the Access Provider and the relevant Licensed Operators in the Kingdom, the Access Seeker and the Access Provider shall execute in writing the Agreement by signing the present Schedule 9 (Supply Terms), which incorporates, by reference, all the other Schedules and parts of the Reference Offer, as effective at the time of the signature, and altogether form the Agreement between the Parties. For the avoidance of doubt, the Agreement shall not include any other term and/or condition not set out in the Reference Offer unless expressly approved in writing by the Authority.
- 1.2 As of the Agreement Effective Date, these Supply Terms apply to any Services ordered by an Access Seeker alongside other Schedules and parts of the Reference Offer.
- 1.3 If the Authority approves or mandates any change to the Reference Offer following the Agreement Effective Date, then the Agreement between the Parties including these Supply Terms shall be automatically amended to incorporate the same change in respect of the Services and other terms covered by such changes.
- 1.4 If the rights and obligations of either Party under the Agreement are or may be affected by:
- (a) amendments to or repeals of the Law or of a condition of a Party's License; or
 - (b) Decision of the Authority (other than any adverse effect on the Access Provider as a result of a mandated or approved change to the Reference Offer), or
 - (c) Force Majeure Event, or
 - (d) ruling of any court in the Kingdom of Bahrain
- the Parties shall meet as soon as practicable and negotiate in good faith any amendment to the Agreement necessary or appropriate to ensure that they remain consistent with the Law and/ or the Decision of the Authority and in accordance with the principles of equivalence and non- discrimination. If the Parties cannot agree any amendment, clause 21 applies.
- 1.5 If the Access Provider reasonably believes, based on an action of the Authority, that any part of the Supply Terms contravenes or may contravene any provision of the Law, the Access Provider's License or other statutory requirements, the Access Provider shall consult with the Authority before introducing any amendment to these Supply Terms, which amendment may be subject to the relevant process, including any applicable approval from the Authority, if and where required, for introducing any amendments to the Reference Offer.
- 1.6 Unless provided otherwise in the Reference Offer, the Access Provider shall not amend the Charges unless it has obtained a prior written approval from the Authority. The approval may be subject to conditions, which the Authority considers appropriate, including conditions relating to the effective date

of the changes to the Charges, which shall not pre-date the Agreement Effective Date, and process and timeline for communication of the changes to Licensed Operators.

2 DUTY TO PROVIDE SERVICES AND PROVISIONING

- 2.1 The Supply Terms apply to the supply of Services as set out in the respective Schedule 6 (Service Descriptions) of the Reference Offer.
- 2.2 The Access Provider shall supply the Services requested by the Access Seeker in accordance with and subject to the requirements specified in these Supply Terms.
- 2.3 The Access Seeker shall comply with Forecasting Procedures as set out in Schedule 5 – (Forecasting) of the Reference Offer. Any specific terms in Schedule 6 (Service Descriptions) may override, vary or supplement those procedures.
- 2.4 Each Party shall comply with the provisions of Schedule 6 (Service Description) and each relevant Operations Manual in so far as they apply to the provision of the Services.

3 CHARGES

- 3.1 The Access Seeker shall pay the Access Provider the relevant Charges determined in accordance with Schedule 3 – (Pricing) or any additional provisions in the relevant Service Descriptions of the Reference Offer.
- 3.2 The Charges exclude all applicable Government taxes and surcharges, including any value added tax, sales taxes, duties, fees and levies, all of which shall be the sole responsibility of the Access Seeker and paid promptly when due.

4 BILLING AND PAYMENT

- 4.1 Each Party agrees to comply with the terms and procedures set out in Schedule 4 – (Billing) of the Reference Offer in relation to billing and payment.
- 4.2 The Access Seeker is solely responsible for billing and collecting its charges for services supplied to the Access Seeker Customers using the Services.

5 NETWORK PROTECTION AND SAFETY

- 5.1 Each Party is responsible for the safe operation of its Network, and shall, so far as is reasonably practicable, take all necessary steps to ensure that its Network, its Network operations and implementation of the Agreement:
- (a) do not endanger the safety or health of any person, including the People of the other Party; and
 - (b) do not cause physical or technical harm to the other Party's Network, including but not limited to causing damage, interfering with or causing deterioration in the operation of that Party's Network.
- 5.2 Each Party will manage its Network to minimize disruption to Services and in the event of interruption or failure of any Services, will restore those Services as soon as is reasonably practicable.
- 5.3 A Party shall:
- (a) not use or knowingly permit the use of any Service, or install, connect, link or use (or permit the installation, connection, linking or use of) any telecommunications equipment, in contravention of any applicable law; and
 - (b) be responsible to the Access Provider for anyone else who uses any Service or any part of any Service provided to the Access Seeker, or does anything unauthorized relating to a Service or any part of any Service.
- 5.4 Each Party shall ensure that its Network and operating procedures comply in all respects with the safety requirements established by, or under the Joint Working Manual and the Law.

6 NETWORK ALTERATIONS AND CHANGES

- 6.1 Where the Access Provider intends to make any material alterations or changes to its Network and where such changes would materially impact the provision of the Services, the Access Provider shall give prior written notice of thirty (30) days to the Authority and all Licensed Operators that use the Services.
- 6.2 Where the Authority considers that a change in the Access Provider's Network referred to in clause 6.1 would cause any Licensed Operator to be compelled to make major changes to its own systems in order to access and/or connect and/or utilise the Access Provider's Network, the Access Provider shall be required to obtain the prior written approval of the Authority before implementing such a change.
- 6.3 The notice required by clause 6.1 shall set out the technical details of the proposed change, the timetable of the proposed change and any known impact to the inter-working of the Parties' Networks relevant to Services provided under the Agreement.
- 6.4 The Access Provider shall update any affected party from time to time of any additional modifications to the proposed changes in the Access Provider's Network referred to in clause 6.1, including the timetable for implementation.
- 6.5 Subject to any requirements of the Reference Offer and/ or the Access Provider's License to obtain approval of the Authority, the Access Provider has the right to modify, change or substitute underlying

infrastructure, hardware, software or other technology or the specifications of the Services to improve the functioning or performing of the Services or its Network provided that such modifications do not adversely alter the functioning or performance of the Services supplied to the Access Seeker. Such modifications may include replacement of elements of existing Network infrastructure or systems with alternate technology. The Access Provider shall not make any changes that would restrict Licensed Operators' ability to choose Customer Premises Equipment (CPE) from a range of multiple vendors subject to compliance with the Law and international standards.

- 6.6 Nothing in the Agreement may be construed to preclude the Access Provider from using, modifying or substituting any equipment as reasonably required to provide any of the Services within the scope of the Agreement, provided that the Access Provider shall not restrict Licensed Operators' ability to choose the CPE.

7 EQUIPMENT AND ACCESS TO END USER'S RESPONSIBILITIES

- 7.1 Where the Access Provider provides the Access Seeker with any equipment; or provides, manages or locates equipment at the Access Seeker's (or End User's) premises; as part of any Service (the "**Access Provider's Equipment**"), the Access Provider shall:

- (a) provide or manage the Access Provider's Equipment in accordance with the provisions of the relevant Service Description (Schedule 6); and
- (b) ensure that the Access Provider's Equipment is approved in accordance with Article 38 of the Law.

- 7.2 In relation to such Access Provider's Equipment, the Access Seeker shall:

- (a) arrange for the Access Provider's Equipment to be installed in an accessible and suitable place, free of charge to the Access Provider, leave it installed there and not interfere with it;
- (b) subject to the necessary time to coordinate with the End User, where applicable, ensure access by the Access Provider in order to operate, manage, inspect, repair or replace the Access Provider's Equipment, as and when required;
- (c) provide adequate instructions to the Access Seeker's End User regarding the Access Provider's Equipment;
- (d) pay for repairing or replacing the Access Provider's Equipment if it is lost, stolen or damaged. If the Access Provider's Equipment is lost, stolen or damaged, the Access Seeker will notify the Access Provider promptly upon becoming aware of such loss, theft or damage;
- (e) make sure that any software installed or otherwise deployed by the Access Seeker on the Access Provider's Equipment or on any equipment connected by the Access Seeker to the Access Provider's Equipment, if permitted under this Agreement, (other than software provided by the Access Provider) is not affected by any virus or similar defect;
- (f) follow the Access Provider's reasonable directions, and any directions from the equipment manufacturer, when using the equipment and never use the Access Provider's Equipment for purposes for which it is not designed;

- (g) only use the Access Provider's Equipment at the agreed site location, where one has been specified;
- (h) unless otherwise provided in this Agreement, ensure that the Access Provider's Equipment, shall at all times remain an article of movable property of the Access Provider, who retains full ownership and title to it, including that such equipment must not be made part of or affixed to any real property or any other property; and
- (i) not encumber the Access Provider's Equipment or expose the Access Provider's title to the Access Provider's Equipment to third party claims and will notify the Access Provider if it becomes aware of any third party claim.

7.3 When any of the Access Provider's Equipment is no longer required:

- (a) The Access Provider shall be responsible for the recovery or removal of its equipment, at the Access Provider's sole discretion.
- (b) The Access Seeker shall be obliged to provide reasonable cooperation and shall allow the Access Provider access to the Access Seeker's or the End User's premises at all reasonable times upon reasonable advance notice to enable the Access Provider to remove its equipment, and to provide any reasonable assistance required; and
- (c) The Access Seeker shall not have any responsibility to the Access Provider for Access Provider's Equipment that has not been removed by the Access Provider within a reasonable timeframe after it is no longer required.

7.4 If the Access Provider fails to remove its equipment under clause 7.3 within a reasonable timeframe or as otherwise agreed between the Parties, then the Access Seeker may remove it with no liability to the Access Provider.

7.5 For the Access Seeker's own safety, and so that provision of the Services to the Access Seeker, the End Users and other Licensed Operators is not disrupted, the Access Seeker shall help safeguard the Access Provider's Network and the Access Provider's Equipment.

7.6 The Access Seeker shall:

- (a) Ensure that the Access Provider have reasonable and safe access to the Access Seeker's (or End User's) premises:
 - (i) to maintain, operate, manage, inspect, repair, replace or develop the Access Provider's Network or the Access Provider's Equipment;
 - (ii) to fix any Fault or replace any equipment; or
 - (iii) for any other reasonable purpose,
- (b) provided that the People whom the Access Provider uses carry proof of their identity and follow the Access Seeker's reasonable access management procedures. The Access Seeker shall ensure any applicable access management procedures are communicated to the Access Provider;
- (c) follow the Access Provider's reasonable directions when connecting any Customer Premises Equipment to the Access Provider's Network or the Access Provider's Equipment and make sure

it is installed to the Access Provider's specifications and has obtained the type approvals as required by the Law;

- (d) unless expressly authorised by the Access Provider in writing, never interfere, tamper or connect any other equipment to the Access Provider's Network or the Access Provider's Equipment, as applicable, and ensure only People the Access Provider authorizes may work on it;
- (e) pay the Access Provider's costs for repairing or replacing any part of the Access Provider's Network or the Access Provider's Equipment, which is lost or damaged by the Access Seeker, or by anyone the Access Seeker is responsible for except for normal wear and tear; and
- (f) make sure everyone the Access Seeker is responsible for also meets these responsibilities.

- 7.7 Without prejudice to the provisions governing a particular Service as set out in the relevant Service Description, the responsibility of the Access Provider for the supply of any Service including compliance with any associated Service Levels, shall be limited to the Access Provider's Network up to the respective Network Termination Point (NTP), which represents a general demarcation between (i) the Access Provider's Network and responsibility, and (ii) the Access Seeker's Network or any equipment or facility of End User and their respective responsibilities. As a general rule, and subject to any other provision of this Agreement, any equipment or facility connected to the Access Provider's Network beyond such NTP remains the sole responsibility of the Access Seeker, or the End User, as the case may be.
- 7.8 Notwithstanding the above, the availability of, and access to, any fixed passive physical infrastructure, beyond the Distribution Point, which may be required for extending the Access Provider's Network to provide the relevant Service, is not part of the Access Provider's Network and falls outside of the Access Provider's responsibility under this Reference Offer. The availability of, and access to, such civil infrastructure associated with the access to End User's premises, including in particular but without limitation any lead-in ducts or similar conduits, in-building wiring beyond the building entry point or a telecom room in multi-dwelling units up to the NTP, remains the sole responsibility of the Access Seeker and the Access Seeker Customer, as the case may be. For the avoidance of doubt and in the case of multi-dwelling units, this excludes scenarios where the Access Provider, pursuant to an agreement with the building owner, has fully deployed the internal wiring or in-building solution connecting each individual unit in the multi-dwelling unit.
- 7.9 The detailed allocation of responsibility of the Access Provider and the Access Seeker in relation to a particular Service and in particular the Access Seeker's responsibility for making available such infrastructure and access to End Users, are described in the Service Descriptions.

8 QUALITY OF SERVICE

- 8.1 To the extent permitted by law, and unless provided otherwise in the Agreement, the Access Provider has no obligation to the Access Seeker in respect of the quality of any Service, except as set out in this clause 8.
- 8.2 Subject to trivial differences as determined by the Authority or any other differences to be agreed between the Access Provider and the Authority, as well as other instances provided for in the Access Provider's Licence, the Access Provider shall:
- (a) ensure that each Service that it provides to an Access Seeker is of an equivalent quality, including in relation to the availability of any enhanced features, to that which it supplies to all other Licensed Operators that receive the same Service; and
 - (b) maintain and repair Faults in Services in an equivalent manner to the manner in which it maintains and repairs Faults in Services for all other Licensed Operators.
- 8.3 Subject to clauses 8.4 and 8.5, the Access Provider shall:
- (a) provide, but does not guarantee the provision of, continuous or Fault-free Services to the Access Seeker; and
 - (b) comply with any Quality of Service requirements set out in the relevant Service Description in Schedule 6 (Service Descriptions) of the Reference Offer, and
 - (c) provide the Service at the relevant Service Levels set out in Schedule 7 (Service Levels) of the Reference Offer.
- 8.4 Save to the extent required under applicable law, or as expressly set out in Schedule 7 (Service Levels), the Access Provider does not give or make any warranty, representation, undertaking or commitment in respect of the quality of service applicable to any Service, and any implied warranty to this effect is excluded, including any warranty, representation, undertaking or commitment (whether made to the Access Seeker before the Agreement Effective Date or otherwise) in respect of any difficulty or Fault resulting in a failure to establish any Service, in-service interruption, or loss, or distortion, of communication.
- 8.5 If any applicable law implies warranties or conditions or imposes obligations on the Access Provider in respect of the quality of service of any Service, which cannot be or can only to a limited extent be, excluded, restricted or modified, then to the extent to which the Access Provider is entitled to do so, the liability of the Access Provider under the applicable law is limited:
- (a) to the supply of relevant Services again or the payment of the cost of having the relevant Service supplied again, at the Access Provider's option;
 - (b) to the repair or replacement of property or paying the cost of repair or replacement, at the Access Provider's option; or
 - (c) to any other remedy prescribed by applicable law.

- 8.6 The Access Provider shall have no liability (including without limitation liability to provide Service Level Penalty or Penalties/ credit any Service Credit) for any failure to meet a Service Level for the period and to the extent Access Provider's ability to perform in accordance with the Service Level is adversely affected or materially contributed to by:
- (a) any act or omission of the Access Seeker that is not in accordance with this Agreement or that is otherwise unlawful, including a breach by the Access Seeker of the terms of the Agreement in relation to any Service;
 - (b) any event or circumstance to the extent caused or contributed to by:
 - i. the Access Seeker's Network, platform, system, software or equipment; or
 - ii. the network, systems, equipment, software or facilities of any End Users, or
 - (c) failure by the Access Seeker Customer to provide cooperation, assistance or other liaison with the Access Provider that is reasonably required for the supply or maintenance of any Service including any time required by the Access Seeker to coordinate with the End User to arrange for access by the Access Provider to the End User's premises where such access is required to operate, manage, repair or replace any Access Provider's Equipment or perform activity on the Access Provider's network;
 - (d) any Force Majeure Event;
 - (e) any failure of, or inability to supply products, services, facilities or infrastructure by a third party, where the third party is unable to perform its obligations to Access Provider as a result of an event that would have otherwise constituted a Force Majeure Event and where the Access Provider is reasonably unable to procure supplies from alternative suppliers, if the obligations to be performed by the third party had arisen under this Agreement;
 - (f) the implementation of any material Network or system upgrade, relocation or replacement of any Access Provider's Facilities or technology in accordance with the terms of this Agreement;
 - (g) any event or circumstance beyond the reasonable control of the Access Provider, which does not otherwise constitute a Force Majeure Event or is not otherwise due to an act or omission of the Access Provider such as, for example, major network break down or Facility disruption caused by third party's act or omissions; or any third party equipment not operated or managed by or on behalf of the Access Provider;
 - (h) inability to obtain or delays in obtaining by the Access Provider the necessary wayleaves NOCs, and/or permissions from government authorities, municipalities or any third parties as long as (i) the Access Provider made all reasonable efforts to obtain them, including (ii) making the relevant applications in a timely manner, (iii) notifying the Access Seeker of such requirement and (iv) keeping the Access Seeker updated on the progress, or
 - (i) a Regulatory Event.

8.7 The Access Provider shall have no obligation to meet any Service Level during any period for which the relevant Service(s) are suspended pursuant to clause 11.

8.8 Non-compliance with any Service Level as set out in Schedule 7 (Service Levels) by the Access Provider, despite not constituting a breach of the Agreement, establishes the right of the Access Seeker to raise with the Access Provider a Service Credit Claim no later than (i) two (2) calendar months of becoming aware of such non compliance and (ii) no later than three (3) calendar months after it occurred.

8.9 Where the Access Seeker monitors Quality of Service to measure the actual performance of the Access Provider against the relevant Service Level(s) within certain periods of time chosen by it, then the Access Seeker may, following the end of each such period but no later than within the timelines stipulated in clause 8.8, raise a Service Credit Claim for additional Service Credit (subject to any Total Service Credit Cap specified in the relevant Schedule 7 (Service Levels), which additional credit if valid, will be credited by the Access Provider in the same way as described below in clause 8.10. For avoidance of doubt, irrespective of the method that may be chosen by the Access Seeker for claiming any Service Level Penalties, a breach of a particular Service Level by the Access Provider cannot give rise to more than one Service Level Penalty.

8.10 The Access Provider shall be obliged to review any Access Seeker's Service Credit Claim submitted to it and respond to the Access Seeker within a reasonable time frame, but in any case no longer than in 30 calendar days following its submission by the Access Seeker.

8.11 After verifying the Access Seeker's entitlement to a Service Credit and where the Access Provider has accepted the Service Credit Claim, and subject to any Total Service Credit Cap in respect of any Service Level, the Access Provider shall apply the amount of that Service Credit as a credit towards the Charges payable by the Access Seeker, for the billing period following such verification and, where required, for each subsequent period until the total amount of the applicable Service Credit (subject to a Total Service Credit Cap) has been applied in full.

9 NEW SERVICES AND SERVICE ORDERS

9.1 A request from a Licensed Operator for a New Service shall be processed in accordance with the relevant provisions of Annex 1 to the Main Body (New Service Order and New Service Order Process).

9.2 Subject to an Agreement between the Parties, the Access Provider shall process a Service Order in accordance with Schedule 2 – (Notification and Acceptance of Service Order) within the timescales set out in Schedule 7 – (Service Levels) and in accordance with the other terms of the Agreement.

10 USE OF THE SERVICES

- 10.1 The Access Provider acknowledges that the Access Seeker may use the Services provided by the Access Provider as part of services or products that the Access Seeker offers to the Access Seeker Customers. The Access Seeker agrees that where it provides services or products to the Access Seeker Customer using any Service, or part of any Service:
- (a) the Access Seeker will indemnify the Access Provider for any damage, loss or cost (including legal costs) and protect the Access Provider from any claim or proceeding:
 - (i) arising from the failure by the Access Seeker to obtain, or a claim by an End User that the Access Seeker failed to obtain, that End User Consent relevant to the supply of Services relating to that End User;
 - (ii) to the extent caused, contributed to or brought by any Access Seeker Customer directly or indirectly in connection with the Services;
 - (b) the Access Provider will not be responsible to the Access Seeker or any Access Seeker Customer for any failure or delay in provision of a Service where such failure or delay is caused by or contributed to by any action or inaction of the Access Seeker or of any Access Seeker Customer; and
 - (c) the Access Seeker will be solely responsible for any misuse of a Service or part of a Service by the Access Seeker Customers and the Access Seeker will be liable accordingly.
 - (d) The Access Seeker shall not re-sell or re-supply the Service to any other Licensed Operator for that Licensed Operator's provision of its own retail services. For the avoidance of doubt, a re-sell or re-supply of the Service means to sell or supply the Service to any other Licensed Operator.

11 SUSPENSION

- 11.1 The Access Provider may only suspend a Service to the extent necessary to address:
- a. an emergency requiring suspension as further detailed in clauses 11.2 to 11.4; or
 - b. a request from the Authority to suspend a Service.

The parties acknowledge that suspension may be potentially disruptive for users of telecommunications networks in Bahrain and that an assessment of whether or not to suspend a Service in particular circumstances should consider the interests of potentially affected users as a whole.

- 11.2 Subject to clause 11.1, the Access Provider may suspend the supply or use of a Service provided to the Access Seeker, by giving the Access Seeker forty-eight (48) hours' written notice if, in the reasonable opinion of the Access Provider, the Access Seeker's Network has a material adverse effect on the safe, secure or normal operation of the Access Provider's Network or similar detrimental impact on the continuous and uninterrupted supply of Services to other Licensed Operators, and the Access Seeker has failed to rectify the material adverse effect before the end of a notice period of (i) not less than thirty (30) days in usual circumstances, and (ii) not less than seven (7) days in urgent cases, provided that:

- (a) before suspending the supply or the use of a Service, the Access Provider has notified the Authority at least forty-eight (48) hours ahead of its intended suspension; and
- (b) the Access Provider will not suspend the supply or use of a Service where the Authority having received the notice referred to earlier in this clause, objects in writing to that suspension.

11.3 The Access Provider may suspend the supply or use of a Service, where:

- (a) the Access Seeker committed a Material Breach, and has failed to rectify the Material Breach after the Access Provider has taken all the following consequential steps, each time giving the Access Seeker at least seven (7) calendar days to rectify such Material Breach:
 - i. the Access Provider notified the Access Seeker in writing of the Material Breach and invited it to rectify it, and
 - ii. the Access Provider suspended the application of all Service Levels and Service Level Penalties to the relevant Access Seeker; and
 - iii. the Access Provider has suspended processing of any new Service Orders raised by that same Access Seeker,

unless the Authority, after having been notified by the Access Provider at least 30 days in advance of its intention to suspend the Service and the reason for such suspension, objects against it in writing or has issued a determination prohibiting the Access Provider from the suspension on the grounds of an overriding public interest in continuation of any such Service; or

- (b) the Access Seeker knowingly or recklessly used, attempted to use, or has communicated or demonstrated an intention to use, any Service supplied under the Agreement in contravention of any law; or

(c) with the exception of operation matters or inaccurate forecasts as provided for in Schedule 5 (Forecasting), any material information provided, or material representation made, by the Access Seeker to the Access Provider is untrue, false, grossly misleading or inaccurate and the difference between the effect of the Access Provider's reliance on the information and what would otherwise be the case if the information or representation had been true or accurate, is reasonably considered material by the Access Provider (with respect to the provision of the relevant Services).

11.4 Subject to clause 11.1 the Access Provider may suspend the Agreement or a Service, respectively, provided to the Access Seeker, on not less than seven (7) days' notice if in the reasonably justified opinion of the Access Provider:

- (a) the Access Seeker's Network or the supply of any Service to the Access Seeker poses:
 - (i) a threat to life or safety of any person (which shall not include a threat to life or safety of any person via the supply of any Service to the Access Seeker);
 - (ii) a material hazard to equipment or the property of any person, including the Access Provider;
- or

- (iii) an imminent threat to the normal operation, access, integrity or security of the Access Provider's or continuous and uninterrupted supply of Services to other Licensed Operators or Access Provider's or other Licensed Operator Network;
 - (b) the Access Seeker becomes Insolvent, provided that this right will not be exercised:
 - (i) for so long as the Access Seeker fulfils all its obligations, including paying all amounts, as and when they fall due in the course of any Insolvency; and
 - (ii) for so long as the Security provided by the Access Seeker remains effective and is sufficient to meet the sum of debts actually payable and reasonably foreseeable in the course of the Insolvency;
 - (c) there is an emergency situation that in the Access Provider's reasonable opinion may lead to a state of danger to the national safety or martial law being announced and the requisition by a competent authority of the Access Provider's telecommunications networks or services used to provide one or more of the Services;
 - (d) the continued supply of any Service would be unlawful, or compliance with legal or regulatory obligations or any instruction, order, direction, decision or request from any competent or government authority in the Kingdom requires the suspension of one or more of the Services and where such unlawfulness or non-compliance has been confirmed by the Authority; or
 - (e) the Authority or a relevant governmental authority directs the Access Provider to do so.
- 11.5 If, pursuant to clauses 11.1 to 11.4, a Service has been suspended in accordance with the Agreement due to reasons attributable to the Access Seeker, the Access Seeker shall continue to pay the relevant Charges for that Service during the period of suspension, and shall pay the Access Provider any Charge payable for the reconnection or reinstatement of that Service, except that where the cause of suspension was outside the control of the Access Seeker. The Access Seeker may request, where the cause of suspension was outside the control of the Access Seeker, that the Access Provider provide a waiver of reconnection or reinstatement Charges and a waiver of Charges applicable during the period of suspension.
- 11.6 If any Service is suspended under clause 11.2 or 11.3 for more than thirty (30) calendar days, then either Party may terminate the relevant Service with immediate effect by giving the other a written notice.
- 11.7 The Access Provider's exercise of its right to suspend a Service does not prejudice any other right or remedy available to it at law or in contract, including any subsequent right to suspend or terminate that Service or a different Service.
- 11.8 If the circumstances giving rise to a right of suspension are cured during any period of notice or suspension and such cure is objectively explained and evidenced in writing to the Access Provider:
- (a) before the right is exercised, then the right to suspend may not be exercised; or
 - (b) after the right is exercised, then the Access Provider shall lift the suspension as soon as reasonably practicable and in any event within forty-eight (48) hours of the notice of cure, except with respect to a right of suspension exercised pursuant to clauses 11.2 in relation to which the Access Seeker

shall give an undertaking that, as far as it is reasonably aware, the circumstances giving rise to the right of suspension are unlikely to recur, or that the Access Provider is otherwise protected against the consequences of the circumstances.

12 TERMINATION

- 12.1 The Access Provider may terminate the supply of any Service, by giving the Access Seeker (and copying the Authority) thirty (30) calendar days' written notice if any of the circumstances exist, which would give the Access Provider the right to exercise a right of suspension under clause 11.2 in respect of that Service.
- 12.2 The Access Provider may also terminate the supply of any Service by giving the Access Seeker (and copying the Authority) thirty (30) calendar days' written notice if:
- (a) the Access Seeker committed a Material Breach, and
 - i. the Access Provider has suspended the Service, or the Agreement, or
 - ii. has taken any other step envisaged pursuant to clause 11.3(a) but the Access Seeker has failed to rectify the Material Breach within additional seven (7) calendar days after the Access Provider has taken the last of the steps described in clause 11.3(a);
 - (b) the Access Seeker becomes Insolvent, provided that this right will not be exercised for so long as the Access Seeker fulfils all its obligations, including paying all amounts as and when they fall due in the course of any Insolvency;
 - (c) subject to clause 14, notified Force Majeure Event or Regulatory Event substantially adversely affects the ability of the Access Provider to perform its obligations under the Agreement for a continuous period of forty-five (45) calendar days, provided that the Access Seeker may require during the notice period that the Parties, on reasonable notice, engage in discussions with each other, the ECTC, or the Authority, as applicable, to establish whether alternative terms of supply can apply. Any amendment shall be made only in accordance with the provisions of the Reference Offer.
- 12.3 The Access Provider may terminate any Service by giving the Access Seeker (and copying the Authority) ninety (90) calendar days' written notice if:
- (a) the Access Seeker is no longer eligible to that Service, and the Access Provider has evidence to prove it; or
 - (b) the applicable law or the Authority no longer imposes an obligation on the Access Provider to provide that Service and the Authority has approved the removal of the relevant Service from the Reference Offer.
- 12.4 Either Party may terminate the supply of any Service by giving the other Party (and copying the Authority) seven (7) days' written notice if:

- (a) the continued operation of the Agreement would be unlawful or contravene legal or regulatory obligations of either Party; or
- (b) the Access Seeker ceases to be a Licensed Operator; or
- (c) the Access Provider's License is revoked by the Authority.

12.5 If the Authority revokes the Reference Offer, then the Agreement automatically and immediately terminates on the date of such revocation.

12.6 If the circumstances giving rise to a right of termination are cured during any notice period or period of remedy and such remedy is objectively evidenced in writing to the terminating party before the expiry of that notice period or period of remedy then (except in cases where the terminating party is terminating for a persistent curable breach or the breach is of its nature past and incurable) the Agreement or the relevant Service shall not terminate.

12.7 Where in this clause a reference is made to a notice of termination copying the Authority, it is deemed that Access Provider is entitled to proceed with the termination of the relevant Service, subject to the Authority not issuing, within the same notice period and pursuant to the applicable law, any express order or direction prohibiting the Access Provider from such termination.

13 CONSEQUENCES OF TERMINATION

13.1 On termination of a Service:

- (a) all sums payable to the Access Provider under the Agreement up to the date of termination, including any Charges in respect of termination, are immediately due and payable;
- (b) the Access Provider shall refund any amount or proportionate amount paid by the Access Seeker in respect of any period after the date of termination;
- (c) unless provided otherwise, all Services, leases, licenses and other rights conferred on the Access Provider or the Access Seeker under the Agreement immediately terminate;
- (d) each Party shall at its own expense immediately return all of the other Party's equipment or other property used for any of the Service (other than any Access Provider's Equipment, which shall be dealt with in accordance with Clause 7.3 and 7.4) in good working condition, other than fair wear and tear;
- (e) to the extent permitted by the applicable law, each Party shall at its own expense and for a period of two (2) years after termination of the Agreement in accordance with this clause 13, immediately comply with any written notice from the other Party to deliver, destroy, or erase any Confidential Information belonging to that other Party.

13.2 Each Party shall reimburse the other Party for any cost incurred by that other Party in repossessing or replacing any property (other than any Access Provider's Equipment, which shall be dealt with in accordance with Clause 7.3 and 7.4) that was not returned within thirty (30) calendar days after the date of termination or was returned in a damaged or defective condition.

13.3 Termination or expiry of the Agreement or any Service:

- (a) is deemed not to be a waiver or breach of any term or condition of any element of the Agreement; and
- (b) does not prejudice any right, liability or obligation that accrued to either Party before the date of termination or expiry.

13.4 All rights that each Party accrued before termination or expiry of the Agreement or any Service, and clauses 4 (Billing and Payment), 15 (Liability and Indemnity), 16 (Intellectual Property), 19 (Confidentiality) and 21 (Dispute Resolution) and 22 (General), survive termination or expiry of this Agreement or that Service (as the case may be), and continue in full force and effect.

14 FORCE MAJEURE AND REGULATORY EVENTS

14.1 Subject to clause 14.2, neither Party shall be liable for any failure to comply with or observe any term of the Agreement to the extent that a Force Majeure Event or a Regulatory Event caused that failure.

14.2 Each Party remains liable for the performance of each obligation, and to comply with and observe each term, of the Agreement, which is not affected by the Force Majeure Event or Regulatory Event.

14.3 The Access Seeker remains liable for all sums payable in respect of each Service provided by the Access Provider during the Force Majeure Event or Regulatory Event, which is not affected by the Force Majeure Event or Regulatory Event.

14.4 If a Party fails to comply with or observe any term of the Agreement because of a Force Majeure Event or a Regulatory Event, then that Party shall notify the other Party:

- (a) as soon as practicable upon its occurrence, giving details of the Force Majeure Event or Regulatory Event, and its estimated extent and duration, if foreseeable to it; and
- (b) immediately after the end of the Force Majeure Event or Regulatory Event.

15 LIABILITY AND INDEMNITY

15.1 To the extent permitted by law, neither Party is liable to the other Party except as provided in:

- (a) this clause 15; or
- (b) in relation to supply or use of a particular Service, the relevant Service Description in Schedule 6 – (Service Descriptions) of the Reference Offer.

15.2 If any applicable law implies warranties or conditions or imposes obligations on the Access Provider that cannot be, or can only to a limited extent be, excluded, restricted or modified, then to the extent to which the Access Provider is entitled to do so, the liability of the Access Provider under the applicable law is limited:

- (a) subject to agreement of the Parties, to the supply of Services again or the payment of the cost of having the Services supplied again; or
- (b) subject to agreement of the Parties, to the repair or replacement of property or paying the cost of repair or replacement; or
- (c) to any other remedy prescribed by the applicable law.

15.3 Neither Party is liable to the other Party for or in relation to any Consequential Loss.

15.4 Subject to clauses 15.1, 15.2, 15.3, 15.5, 15.6, 15.7, 15.8 and 15.9, each Party's maximum liability under the Agreement is limited to:

- (a) BHD300,000, - (three hundred thousand Bahraini Dinar) for any one event or series of connected events, and
- (b) BHD1,000,000 (one million Bahraini Dinars) in the aggregate for all events (connected or unconnected) occurring in a Calendar Year.

15.5 Clause 15.4 does not apply to any obligation arising under the Agreement to pay monies in the ordinary course of business, including without limitation, the Charges and any other payments in respect of liabilities under clauses 15.6, 15.7 and 15.8.

15.6 Each Party indemnifies the other Party against all awards, judgments, costs, charges and expenses directly and reasonably incurred by that other Party as a result of or in connection with any claim against it arising out of a death of or personal injury to the People of the other Party, to the extent that the damage or loss is caused by a negligent act or omission or an act or omission intended to cause death or personal injury, by the Indemnifying Party or any of the People of the Indemnifying Party.

15.7 Each Party indemnifies the other Party against all costs, charges and expenses directly and reasonably incurred by the other Party as a result of or in connection with any damage to equipment, Network or other tangible property of the other Party or any third party to the extent that the damage or loss is caused by a negligent act or omission by the Indemnifying Party or any of the People of the Indemnifying Party.

15.8 Subject to clause 15.9, each Party indemnifies the other Party against all costs, charges and expenses directly and reasonably incurred by the other Party as a result of or in connection with any claim by a third party against the other Party to the extent that the claim relates to any breach of obligations under the Agreement by the Indemnifying Party or any of the People of the Indemnifying Party.

Except where the action, claim or demand brought or made by a third party arises as a result of or is directly connected with the wrongful termination or suspension by the Indemnifying Party of the Agreement or any Service, the Indemnifying Party is not liable to the other Party to the extent that liability is incurred in connection with an action, claim or demand brought or made against the other Party by a third party to whom that other Party provides a telecommunications service under a contract, where that liability could legally have been excluded or where that liability could legally have been reduced in that contract by that other Party.

- 15.9 Each provision of this clause 15 is a separate limitation applying and surviving even if one or more limitations is inapplicable or held unreasonable in any circumstance.
- 15.10 Subject to clause 8.6, if any Schedule of the Agreement contains a specific remedy for the failure of either Party to perform its obligations under that Schedule, in particular but without limitation to provide a specific Service Level and failing that to provide a specific Service Penalty, then that remedy is, to the extent permitted by the applicable law, the sole and exclusive liability of that Party, its Affiliates, and its People, in connection with the non-performance or a delay in performance with that obligation, and it is also the sole remedy of the other Party against the first Party, its Affiliates and its People in connection with the performance of that obligation. The aforementioned limitation of either Party's liability shall not apply in case the failure to perform the contractual obligation or delay in the performance thereof by such Party, is due to to fraud or gross negligence on the side of that Party.
- 15.11 The Indemnifying Party is not obliged to indemnify the other Party to the extent to which the subject of the indemnity claim is the result of a breach of the Agreement, or a negligent act or omission, of that other Party.
- 15.12 The Party seeking the benefit of an indemnity from the Indemnifying Party shall take all reasonable steps to minimize the loss it has suffered or is likely to suffer as a result of the event giving rise to an indemnity under this Agreement, and if that Party does not take reasonable steps to minimize loss, then the damages payable by the Indemnifying Party shall be reduced as is appropriate in each case.
- 15.13 A Party's liability to the other Party for any loss or liability of any kind arising out of the Agreement or in connection with the relationship established by it, is reduced to the extent (if any) that the other Party causes or contributes to that loss or liability. This reduction applies whether the first Party's liability is in contract, tort (including negligence), under any statute or otherwise.
- 15.14 Without limiting either Party's liability under this Agreement, each Party shall have in force and maintain for the term of the Agreement, with an insurance company licensed in Bahrain and on terms and for coverage limited by only standard industry exclusions or exceptions:
- (a) a broad form public liability policy of insurance to the value of at least BHD250,000 (two hundred fifty thousand Bahraini Dinars) in respect of each claim; and
 - (b) property insurance for those assets used by it under or in relation to this Agreement to the value of at least BHD100,000 (one hundred thousand Bahraini Dinars) in respect of each claim.
- 15.15 On request by a Party, the other Party shall promptly produce evidence that it has complied and is continuing to comply with its obligations under clause 15.14.

16 INTELLECTUAL PROPERTY

- 16.1 Except as otherwise expressly provided in the Agreement, all Intellectual Property Rights remain the ownership of the Party creating or owning them.
- 16.2 Nothing in this Agreement and/or the supply of any Service by the Access Provider to the Access Seeker shall be construed, as:
- (a) an assignment of any Intellectual Property Rights of one Party to the other Party; or
 - (b) the grant of any license to any Intellectual Property Rights of one Party to the other Party.
- 16.3 Without prejudice to or limiting clause 16.1, neither Party is entitled to use any trade marks or service marks (whether registered or not) of the other Party, without the prior written consent of that Party.
- 16.4 Each Party indemnifies the other Party and the other Party's People, against any action, claim, loss, liability, cost or expense that may be brought against, suffered or incurred by any of them arising directly or indirectly from a claim by a third party that the use of the Indemnifying Party's Intellectual Property Rights as permitted under this Agreement infringes the rights of that third party.
- 16.5 The indemnity in clause 16.4 is the only remedy and form of compensation available to a Party in respect of Intellectual Property Rights arising under this Agreement.
- 16.6 The Access Seeker is responsible and liable for obtaining and maintaining in its own name and at its own expense, all licenses, permits, consents, waivers or authorizations related to any Intellectual Property Rights required for it to:
- (a) use any Service provided under this Agreement; or
 - (b) install or use any equipment in connection with the use of any Service provided under this Agreement; or
 - (c) provide any services to Access Seeker Customers based on the Service provided to it by the Access Provider.

17 ACCESS SEEKER'S FORECASTING OBLIGATIONS

- 17.1 The Access Seeker shall provide forecasts to the Access Provider during the term of the Agreement in accordance with the requirements and procedures stipulated in Schedule 5 – (Forecasting) of the Reference Offer.
- 17.2 The Access Seeker shall provide all forecasts in good faith and shall use all reasonable endeavors to ensure that forecasts are accurate. Forecasting accuracy is of paramount importance for efficient engagement of resources to the benefit of legitimate end users, avoiding unnecessary costs or incurring losses by the Access Provider and thus the overall cost of provision of these critical services.

18 CREDIT MANAGEMENT AND SECURITY

- 18.1 The Access Provider may require the Access Seeker to provide Security in relation to the provision of the Services under the Agreement. This may be in response to the first Service Order (“**Initial Security**”) or as varied from time to time under this clause 18.
- 18.2 If Security is required by the Access Provider, the Access Seeker shall provide, at its sole cost and expense, and maintain for the term of the Agreement, Security of the type and value required by the Access Provider in accordance with this clause 18.
- 18.3 The Access Provider may at any time review the creditworthiness of the Access Seeker and take action under clause 18.7 if any of the following circumstances exist:
- (a) where the Access Seeker is rated by Moody’s Investor Services or Standard & Poors, it ceases to have an Acceptable Long Term Credit Rating and/or the Access Seeker does not provide to the Access Provider an appropriate Security;
 - (b) the Access Seeker becomes Insolvent;
 - (c) a Change of Control occurs in respect of the Access Seeker;
 - (d) the Access Seeker has failed to pay undisputed Charges when due at any time during the term of the Agreement;
 - (e) the Access Seeker breaches the terms of any Security provided under this clause 18;
 - (f) in Access Provider’s reasonable opinion, there has been a material adverse change in the Access Seeker’s financial position;
 - (g) the total Charges disputed by the Access Seeker in a three (3) month period exceeds the total Initial Security (as varied from time to time);
 - (h) the Access Seeker wishes to obtain new or additional Services and obtaining of such Services would result in the amount of Security required from the Access Seeker (as calculated in accordance with the general principle set out in Clause 18.10 below) increasing by twenty-five percent (25%) or more from the Initial Security (as varied from time to time) provided by the Access Seeker; or
 - (i) a period of nine (9) months has lapsed since the last review of the Access Seeker’s creditworthiness.
- 18.4 Where the Access Provider conducts a creditworthiness review pursuant to clause 18.3, the Access Seeker shall provide the Access Provider with all information reasonably requested by the Access Provider in respect of the Access Seeker’s creditworthiness within five (5) Working Days after the Access Provider’s request.
- 18.5 If having conducted a creditworthiness assessment of the Access Seeker in good faith in accordance with clause 18.4, the Access Provider considers that the Security coverage of the Access Seeker does not meet the Access Provider’s reasonable requirements, or if the Access Seeker fails to comply with any provision of this clause 18, then the Access Provider may require the Access Seeker to provide a new Security or to vary the amount or type of an existing Security.

- 18.6 If the Access Provider requests new or varied Security under clause 18.5, then the Access Seeker shall provide the new or varied Security, in the form and on terms acceptable to the Access Provider acting reasonably, within five (5) Working Days of the request being made.
- 18.7 Where the request for new or varied Security under clause 18.5 is the result of a creditworthiness assessment carried out by the Access Provider pursuant to clause 18.3(g), the Access Provider shall indemnify the Access Seeker against all costs, charges and expenses directly and reasonably incurred by the Access Seeker in providing the new or varied Security, where (i) the aggregate amount of Charges billed in error compared to (ii) the total amount of the disputed Charges, to be determined as an outcome of a Billing Dispute pursuant to Schedule 4 – (Billing), is more than five (6) per cent of the aggregate of the disputed Charges.
- 18.8 The Access Seeker shall, unless otherwise agreed to by the Access Provider:
- (a) maintain any Security provided to the Access Provider under this clause 18 until the expiry of a six (6) month period after the last to occur of:
 - (i) termination or expiry of the Agreement; and
 - (ii) payment to the Access Provider of all outstanding Charges and other amounts payable by the Access Seeker under the Agreement.
 - (b) the Access Provider may exercise its rights under any Security in respect of any amounts payable by the Access Seeker to the Access Provider under the Agreement, other than any Charges which are the subject of a Billing Dispute.
- 18.9 The Access Seeker warrants to the Access Provider that by providing information to the Access Provider under clause 18.5, except to the extent otherwise disclosed in writing to the Access Provider at the time of the provision of such information that:
- (a) such information constituted true and fair statements of the financial or other positions of the Access Seeker as at the date to which they were prepared; and
 - (b) there has been no material adverse change in the Access Seeker's financial or other position between the date on which any such information was prepared and the date on which the information was provided.
- 18.10 The amount of any Security under this clause 18 will be calculated:
- (a) as a statement of general principle, by reference to the aggregate value of the Charges likely to be payable by the Access Seeker to the Access Provider under the Agreement over a three (3) month period;
 - (b) together with the combined value of any equipment and other assets that the Access Provider has reasonably procured specifically for the provision of a Service to the Access Seeker by the Access Provider which are:
 - (i) sited on premises owned or controlled by the Access Seeker; or
 - (ii) directly accessible to authorised People of the Access Seeker; and

(c) will be recalculated at the request of either Party if the period since the last review of the amount of Security is greater than nine (9) months.

18.11 Each Party may use any current estimates, forecasts or any other statements made or provided by the other Party in making any calculations pursuant to clause 18.10.

18.12 In addition to the Access Provider's other rights and remedies and Schedule 4 – (Billing), if the Access Seeker has at any time failed to pay undisputed Charges by the Due Date, the Access Provider may require the Access Seeker to pay all Charges in respect of Services on presentment of invoice or monthly in advance, in which case the assessment of future Charges will be based on either:

- (a) the highest level of actual monthly Charges; or
- (b) where the relevant Services have not been provided for three (3) calendar months, the greater of the higher level of actual monthly Charges or the higher level of forecast monthly Charges; in respect of such Services in the three (3) calendar months prior to that in respect of which the Charges are to be paid for such Services.

19 CONFIDENTIALITY

19.1 Either Party shall ensure privacy and confidentiality of Confidential Information of the other Party obtained under or in relation to this Agreement and protect it against unauthorised disclosure, by establishing and implementing reasonable procedures for maintaining privacy and confidentiality of such information subject to any requirement under applicable law.

19.2 The Access Provider shall not in any circumstances disclose in breach of any applicable law to any of its Affiliates, which is a Licensed Operator or which engages in retail communications operations in relation to any Service under this Agreement, directly or indirectly, any Confidential Information relating to any other Licensed Operator. The Access Provider shall establish and maintain, at all times, organisational measures including in particular appropriate information barriers, processes and systems to prevent the disclosure of such Confidential Information by the Access Provider to any such Affiliate.

19.3 Unless otherwise provided in this Agreement, the Access Provider shall not in any circumstances disclose to any Licensed Operator directly or indirectly, any Confidential Information relating to any other Licensed Operator.

19.4 A Party may not disclose the provisions of this Agreement to any person except:

- (a) after obtaining the written consent of the other Party, and only to the extent of that consent;
- (b) subject to clause 19.2, to:
 - i. its officers, employees and professional advisers; or
 - ii. third party suppliers, vendors or contractor which are engaged in provision of Services covered by the Agreement;
- (c) to Emergency Services;

- (d) to any arbitrator or expert appointed under the Dispute Resolution Procedures; or
- (e) as otherwise specified in this Agreement,

and shall use all its reasonable endeavors to ensure all permitted disclosures are kept confidential, other than a disclosure required to be made to a recognized stock exchange.

19.5 Subject to the specific provision of the Agreement already being in the public domain by virtue of publication of the present Reference Offer by the Authority, a Party may disclose the this Agreement in whole or in part:

- (a) to the Authority including for the purpose of providing it with any completed agreement under the Reference Offer as required by the Law, or for the purpose of a review or determination by the Authority or any disputes or complaints submitted to it;
- (b) as required by applicable law, the Authority, the Law, a License, a court order, or any other governmental authority.

19.6 Despite any other provision of this Agreement, the Parties shall not reveal, make known or divulge to any third party in any manner whatsoever the Charges and contents of those aspects of the Agreement (in whole or in part) that the Authority has withheld from publication.

19.7 Except as otherwise provided in this Agreement, a Party that receives Confidential Information ("**Receiving Party**") shall keep confidential all Confidential Information of the other Party ("**Disclosing Party**"):

- (a) disclosed, communicated or delivered to the Receiving Party under the Agreement; or
- (b) that comes into the Receiving Party's knowledge or possession in connection with the Agreement.

19.8 The Receiving Party shall not use or copy the Confidential Information of the Disclosing Party except in connection with and for the purposes of exercising its rights and performing its obligations under this Agreement or in connection with the provision of Services.

19.9 If the Receiving Party visits any of the facilities of the Disclosing Party, the Receiving Party undertakes to keep strictly confidential any Confidential Information that comes to its knowledge as a result of such visit, and any Confidential Information relating to any plant and equipment seen at the facilities, their methods of operation and their various applications, and and subject to clause 19.2 not to divulge the Confidential Information to any third party, other than for the purpose of and only to the extent necessary to perform its obligations under this Agreement.

19.10 Except as otherwise provided in this Agreement and subject to clause 19.2, the Receiving Party shall not disclose or communicate, cause to be disclosed or communicated or otherwise make available Confidential Information to any third party other than:

- (a) the Receiving Party's professional advisers, but only to the extent necessary for those advisers to provide advice or protect the rights of the Receiving Party under this Agreement or at law; and

(b) the Receiving Party's appointed financial advisers or appointed bankers only to the extent necessary for those financial advisers or appointed bankers to provide financial advice or services to the Receiving Party, (each an "**Authorized Person**", and collectively "**Authorized Persons**").

19.11 The Receiving Party shall advise each Authorized Person of the obligation to protect the Disclosing Party's Confidential Information in a manner consistent with the Agreement.

19.12 The Receiving Party may disclose some or all of the Confidential Information to the Authorized Persons, provided that:

- (a) prior to disclosure, in the case of Authorized Persons referred to in clauses 19.10(a) or (b), the Receiving Party shall ensure that Authorized Persons to whom all or any Confidential Information is disclosed hold it strictly confidential and do not disclose it to any other person; and
- (b) prior to disclosure, in the case of Authorized Persons referred to in clause 19.10(c), the Receiving Party must obtain and provide to the Disclosing Party a written undertaking in favor of the Disclosing Party from the Authorized Persons, agreeing to comply with the provisions of this clause 19 of this Agreement as if the Authorized Person were a party to thereto; and
- (c) the Access Provider in its capacity as the Receiving Party is expressly prohibited from disclosing the Confidential Information in breach of any applicable law to any Affiliate of the Access Provider, which is a Licensed Operator or which engages in retail communications operations in relation to any Service under this Reference Offer in the Kingdom, or to any Authorized Person who is reasonably likely to disclose that Confidential Information to such Affiliate of the Access Provider.

19.13 For the purposes of this clause, "Confidential Customer Information" means Confidential Information relating to Access Seeker Customer or any person who is in the process or becoming or may reasonably become Access Seeker Customer; and Confidential Customer Information shall be understood to include all information related to such Access Seeker Customer, to the extent to which the Access Seeker will use any Service under the Agreement for supply of its own products or services to such customer, that is reasonably considered to be commercially confidential (regardless of whether it has been formally designated as such).

19.14 The Parties acknowledge that:

- (a) the provisions of clause 19.2 shall also apply to the Access Provider in respect of any Confidential Customer Information;
- (b) in relation to the Access Seeker only, the Authorized Persons referred to in clause 19.10(a) may engage in multiple roles or functions and the Access Seeker will not be in breach of this clause 19 merely because Confidential Customer Information is provided to an Authorized Person referred to in clause 19.10(a) who has a role or function, including any sales or marketing role or function, other than in connection with or for the purpose of this Agreement, or for any other purpose related to the provision of Services by the Access Provider under the Agreement; and

(c) Confidential Customer Information does not include information which was generated from a party's own billing records relating to its customers.

19.15 In any event, the Receiving Party is liable for any disclosure by the Authorized Persons to any other person.

19.16 The Receiving Party may only issue news releases, public announcements or any other form of publicity concerning the Agreement if it has first obtained the Disclosing Party's written consent.

19.17 A Receiving Party shall exercise no lesser security or degree of care than that party applies to its own Confidential Information of an equivalent nature, but in any event not less than the degree of care that a reasonable person with knowledge of the confidential nature of the information would exercise.

19.18 Confidential Information provided by one Party to the other Party is provided for the benefit of that Party only and may only be used for the purposes for which it is disclosed.

19.19 Each Party acknowledges that a breach of this clause 19 by one Party may cause the other Party irreparable damage for which monetary damages would not be an adequate remedy. Accordingly, in addition to other remedies that may be available, a Party may seek injunctive relief against that breach or threatened breach.

19.20 All and any part of written Confidential Information (including information incorporated in computer software or held in electronic storage media) together with any analyses, compilations, studies, reports or other documents or materials prepared by the Receiving Party or on its behalf, which reflect or are prepared from any of the Confidential Information provided by the Disclosing Party, must be returned to the Disclosing Party or destroyed by the Receiving Party, as directed and when requested by the Disclosing Party at any time, or when the Receiving Party's need for that information has ended or when these Supply Terms expire or terminate, whichever is earlier. In the event of destruction, the Receiving Party shall certify in writing to the Disclosing Party within thirty (30) calendar days that destruction has been accomplished. The Receiving Party shall make no further use of that Confidential Information nor retain that Confidential Information in any form whatsoever.

19.21 The Parties acknowledge that the provisions of this clause 19 continue in full force and effect regardless of variations, assignments or termination of other provisions of this Agreement. The obligation to maintain the confidentiality of the Confidential Information and the undertakings and obligations in this clause 19 continue until the later of two (2) years after the expiry or termination of this Agreement, or when the information ceases to be confidential.

19.22 Notwithstanding anything else in this clause 19, the Access Provider may collect and further process information about the Access Seeker and the Access Seeker Customers. The information may originate from the Access Seeker, other persons or generated by the Access Provider's Network or its systems in connection with the supply and use of the Services.

19.23 The Access Provider may (subject to clause 19.2):

- (a) hold the information and share it with its officers, employees, contractors, suppliers, vendors or other agents, but only where this is necessary to enable the Access Provider to provide the Access Seeker with Services, send the Access Seeker invoices, check that the Access Seeker's responsibilities are being met, or otherwise exercise its rights or perform its obligations, administer and enforce the terms of the Agreement;
- (b) share with Access Seekers any information needed to enable the Access Seeker to send or receive messages of any kind through those networks;
- (c) use any information about the Access Seeker in order to ensure compliance with non-discrimination or similar clauses in contracts between the Access Provider and other Access Provider customers (including other Licensed Operators); and
- (d) use any information about the Access Seeker for statistical purposes, so long as the Access Seeker is not identified.

20 RELATIONSHIP BETWEEN THE PARTIES

20.1 The relationship between the Parties is one of independent contractor only and nothing in this Agreement may be construed to constitute a relationship of agency or partnership between the Parties. Each Party remains fully responsible for its own acts and defaults (including those of its employees or agents). Neither Party is authorized to bind the other Party to any obligation. The Parties and their employees, agents and representatives shall not engage in any conduct that may lead any person to believe that it is an employee, agent or representative of the other Party.

20.2 The Access Seeker shall not imply or represent that the Access Provider:

- (a) participates (other than as a wholesale supplier to the Access Seeker) in the provision of the Access Seekers' services, or is a supplier to the Access Seeker's Customers, or that the Access Seeker is approved by, or an agent or dealer of, or affiliated with, the Access Provider; or
- (b) has a preferred relationship with the Access Seeker, including in respect of special prices or services.

20.3 The Access Seeker shall not in relation to its services to the Access Seeker's Customers falsely attribute to the Access Provider:

- (a) any blame for a fault or other circumstance;
- (b) any need for maintenance or upgrade of a network; or
- (c) any interruption or suspension, or partial interruption or suspension of a service.

20.4 In making any representation contemplated by clause 20.3, the Access Seeker shall not engage in any unfair, unethical, misleading or deceptive conduct.

20.5 The Access Provider shall not be involved in or seek to involve itself in a direct relationship with the Access Seeker's End Users or Access Seeker Customers.

21 DISPUTE RESOLUTION

- 21.1 The Parties shall resolve any dispute, controversy or claim arising between them in respect of this Agreement (“**Dispute**”) in accordance with the procedures below. Any Billing Dispute shall be dealt with in accordance with the provisions of Schedule 4 – (Billing). The process for reviewing, responding to, consulting on and implementing any New Service Order shall be dealt with in accordance with the provisions of Annex 1 to the Main Body.
- 21.2 The Parties shall continue to comply with their respective obligations during a Dispute.
- 21.3 Subject to Clause 19 (Confidentiality), a Party shall not use information obtained in the course of any Dispute Resolution Procedure for any purpose other than to resolve the relevant Dispute.
- 21.4 Either Party’s compliance with the Dispute Resolution Procedures does not prejudice any right or remedy available to that Party in respect of any breach of this Agreement. Nothing in this Agreement prevents a Party from seeking urgent interlocutory, injunctive or other immediate relief, or exercise its right to refer to the Authority any dispute that arises between the Parties with respect to matters of access as provided for in the Telecommunications Law including any requirements stipulated therein.

Dispute Officer and CEO

- 21.5 If a Dispute arises between the Parties, then either Party may, by written notice to the other Party, refer the Dispute to the Dispute Officer of each Party, or a nominee of the Dispute Officer, to resolve the Dispute.
- 21.6 The Parties shall first refer any Dispute to the Dispute Officers before pursuing any other step in the applicable dispute resolution procedure.
- 21.7 The Dispute Officers shall confer and endeavor in good faith on a “without prejudice” basis to resolve the Dispute by negotiating a commercial settlement.
- 21.8 If the Dispute remains unresolved ten (10) Working Days after referral to the Dispute Officers under clause 21.6, then either Party may by written notice to the other Party, refer the dispute to the Chief Executive Officer of each Party, or a nominee of the Chief Executive Officer, who shall confer and endeavor in good faith and on a “without prejudice” basis to resolve the Dispute by negotiating a commercial settlement.
- 21.9 The Parties shall refer the Dispute to the Chief Executive Officers before pursuing any further dispute resolution described below.

Mediation or Determination by the Authority

- 21.10 If the Dispute remains unresolved ten (10) Working Days after referral to the Chief Executive Officers of the Parties under clause 21.9, then either Party may:

- (a) with the express consent of the other Party, refer the Dispute for mediation. The preferred option for mediation in respect of a Dispute shall be for the Parties to jointly appoint a mediator in accordance with the mediation procedures of the International Chamber of Commerce. If the Parties fail to agree on a mediator, the Parties shall request the Authority to appoint a mediator; or
- (b) refer the Dispute to the Authority for determination in accordance with the Law and any conditions stipulated therein.

21.11 The time periods set out in respect of (i) mediation or (ii) determination by the Authority, are intended to coincide with the period of negotiation under the Law, such that a Party makes use of sufficient escalation identified in this clause 21 before referring a Dispute to the Authority for determination.

Arbitration

21.12 If:

- (a) a Dispute remains unresolved sixty (60) Working Days after the appointment of a mediator under clause (a) and neither Party has referred the matter to the Authority for determination; or
- (b) in any case in which the Authority has chosen not to make a determination, then either Party may (except in any case covered by clause 21.10 (b), where the Authority's choice not to determine is expressly or by clear implication dispositive of a question in which specific terms or charges are sought by determination and declined), by written notice to the other Party, refer the dispute for final resolution by compulsory arbitration conducted by three arbitrators in accordance with the Bahrain Arbitration Law (No. 9/2015) provided that the Parties agree that in addition to any other provision or requirement the arbitration and all its proceedings (except the most minimal of formalities if required by law) will be conducted in English.

21.13 Subject to any provision stating otherwise in the Bahrain Arbitration Law (No. 9/2015), the decision of the arbitrators in any arbitration arising under clause 21.12 is final and binding.

Communications

21.14 All discussions and information relating to a Dispute must be communicated or exchanged through each party's Dispute Officer. A party is not entitled to rely on an invoice made, or information provided, in respect of a Dispute by a representative of the other party who is not that other party's Dispute Officer.

22 GENERAL

22.1 Variation

- (a) The Access Provider may only vary the price and non-price terms for the Services and/or the Service Descriptions in Schedule 6 of the Reference Offer with the prior written approval of the Authority.

22.2 Assignment

- (a) Subject to clause 22.2(b), a Party may only assign or transfer its rights, obligations or interests under this Agreement if it has first obtained the other Party's written consent, which shall not be unreasonably delayed or withheld. The Access Provider shall not assign, transfer, subcontract, sublet or otherwise dispose of its rights, duties, liabilities, obligations and privileges under the Agreement to any Affiliate, Person or Persons except with the prior written approval of the Authority. Any such approval shall be given subject to terms and conditions, which the Authority at its discretion may impose. The Authority may revoke its approval pursuant to this clause 22.2 at any time by providing reasonable advance notice to the Access Provider in writing.
- (b) The Access Seeker may only transfer its rights, obligations or interests under the Agreement if:
 - (i) the assignee or transferee is a Licensed Operator and provides the Security required by the Access Provider; and
 - (ii) the Access Seeker remains fully responsible for the performance of all obligations under the Agreement.

22.3 Non-impairment

Neither Party may engage in any conduct that impairs or might impair the other Party's ability to provide services.

22.4 Non-exclusivity

Nothing in this Agreement restricts the rights of either Party to enter into similar agreements with other parties.

22.5 Entire agreement

- (a) Except with respect to any prior agreement which the Parties agree in writing to remain in full force and effect after the Agreement Effective Date, this Agreement supersedes all previous understandings, commitments, representations and agreements between the Parties in respect of the Services covered by the Reference Offer, and contains the entire agreement of the Parties about their subject matter.
- (b) A Party may not rely on any representation or warranty about the subject matter of this Agreement except as expressly provided therein.

22.6 Severance

- (a) Subject to clause 22.6(b), if the whole or any part of any provision of this Agreement is unenforceable, partly unenforceable, void or illegal, then it is severed to the extent necessary to make this Agreement enforceable in the remaining part.
- (b) This clause 22.6 does not apply if the severance materially changes the intended effect of this Agreement, alters its basic nature, or is contrary to public policy.

22.7 Language

The Agreement or the Reference Offer may be translated into other languages, but the English version prevails.

22.8 Waiver

- (a) A right may only be waived in writing and signed by an authorized officer of the Party granting the waiver.
- (b) No conduct of a Party, including a failure to exercise, or any delay in exercising, a right, operates as a waiver of the right or otherwise prevents the exercise of that right.
- (c) A waiver of a right on one or more occasions does not operate as a waiver of that right if it arises again.

22.9 Exercise of rights

A Party may exercise a right, power or remedy at its discretion, and separately or concurrently with another right, power or remedy. A single or partial exercise of a right, power or remedy by a Party does not prevent a further exercise of that or of any other right, power or remedy.

22.10 Counterparts

This Agreement may be executed in any number of counterparts and all those counterparts together make one instrument.

22.11 Governing law and jurisdiction

- (a) This Agreement and the Reference Offer are governed by the laws of the Kingdom of Bahrain.
- (b) Unless provided otherwise in the Agreement, the Parties irrevocably submit to the exclusive jurisdiction of the courts of the Kingdom of Bahrain, and each Party waives any right that it has to object to an action being brought in the courts of the Kingdom of Bahrain, including any objection that the action has been brought in an inconvenient forum, or that the courts of the Kingdom of Bahrain do not have jurisdiction.

22.12 Notices

A notice or other communication given under this Agreement including, but not limited to, a request, demand, consent or approval, to or by a Party to this Agreement shall be:

- (a) in legible writing and in English;
- (b) addressed to the addressee at the physical address or an email set out below or to any other address or email a Party notifies the others under this clause:

(i) if to the Access Provider:

Address: Building No. 1095
Road 1425
Block 1014
Al Hamalah
Kingdom of Bahrain

Attention: Chief Commercial Officer

Email:

CC: Director of Legal and Regulatory Affairs

Email:

(ii) if to the Access Seeker:

Address:

Attention: []

Facsimile: []

- (c) must be signed by an authorized officer of the sender; and
- (d) is deemed to be received by the addressee in accordance with clause 22.12(g).
- (e) Without limiting any other means by which a Party may be able to prove that a notice has been received, a notice is deemed to be received:
 - i. if sent by hand, when delivered to the addressee;
 - ii. if by post, three (3) Working Days after and including the date of postage; and
 - iii. if by email, on receipt by the sender of an acknowledgment or an automatically generated report from the email application confirming delivery to the addressee,
 - iv. but if the delivery or receipt is not on a Working Day or is after 2:45 pm (addressee's time), it is deemed to be received at 7.00 am on the following Working Day.
- (f) In this clause 22.12, a reference to an addressee includes a reference to an addressee's officers, agents or authorized representatives.

- (g) Without prejudice to the above and depending on the nature of the communication between them, the Parties may also rely on established channels of communication at the working level, in particular in relation to operational and technical matters related to ordering and provisioning, repair or maintenance or similar matters.
- (h) In addition, the Access Seeker may submit certain requests, orders, notification or similar forms of communication with the Access Provider in writing using the relevant Access Provider's service platforms, portals or systems consistent with any instruction or manual provided by the Access Provider to the Access Seeker in writing or using other means of communication established between the Parties under this Agreement.

22.13 Legal advice and allocation of risk

Each Party acknowledges that it has received legal advice or had the opportunity to receive legal advice about the Agreement.

22.14 Cumulative rights

The rights, powers and remedies of a Party under this Agreement are cumulative with and do not exclude or limit any other right, power or remedy provided by law or equity independently of the terms of the Agreement.

22.15 Non-merger

The conditions and provisions in the Agreement do not merge on execution.

22.16 Third party rights

Only the Parties have or are intended to have a right or remedy under this Agreement or obtain a benefit under it.

SIGNED on [insert date]

SIGNED BY [INSERT NAME OF SIGNATORY]

Signature of **[insert name of signatory]** as authorised
signatory for
Bahrain Network (BNET) B.S.C (closed) in the presence of:

Signature of witness

Name of witness (print)

SIGNED by **[INSERT NAME OF SIGNATORY]** as authorized signatory
For **[INSERT NAME OF COMPANY]**

Signature of **#insert name of signatory**

in the presence of:

Signature of witness

Name of witness (print)